

PFAFF

1181

1183

Teileliste

Parts list

Lista de piezas

零件表

3511-2/01

3701-4/11

Diese Teileliste hat für Maschinen ab nachfolgender
Seriennummer Gültigkeit:

This parts list applies to machines from the following
serial numbers onwards:

Esta lista de piezas tiene validez para máquinas a partir del
número de serie siguiente:

本零件表对从下列系列号起的机器有效:

PFAFF 1180; 3701 # 6 063 202 →

PFAFF 3511 # 2 736 439 →

Alle Informationen und Abbildungen waren zum Zeitpunkt der Druckgebung auf dem neusten Stand.

Technische Änderungen vorbehalten!

Der Nachdruck, die Vervielfältigung sowie die Übersetzung - auch auszugsweise - aus PFAFF-Teilelisten ist nur mit unserer vorherigen Zustimmung und mit der Quellenangabe gestattet.

At the time of printing, all information and illustrations contained in thisa document were up to date.

Subject to alteration!

The reprinting, copying or translation of PFAFF Parts lists whether in whole or in part, is only pemitted with our previous permission and with written reference to the source.

Todas las informaciones e ilustraciones de este manual estaban al día en el momento de entregarse para su impresión.

¡ Salvo modificaciones técnicas!

La reimpresión, reproducción y traducción - aunque sólo sea parcial - de las listas de piezas PFAFF sólo está permitida con nuestro permiso previo e indicando la fuente.

所有信息和图片在付印时都是最新的。

保留技术更改的权力！

全部或部分翻印、复制以及翻译PFAFF-零件表必须事先经由我们同意并且注明来源。

PFAFF Industrie Maschinen AG

Postfach 3020

D-67653 Kaiserslautern

Königstr. 154

D-67655 Kaiserslautern

	Seite Page Página 页
0 Wichtiger Hinweis	7
Important note	
Observación importante	
重要提示	
1 Vorwort	8
Foreword	
Notas preliminares	
前言	
2 Erläuterungen der Schlüsselzeichen	9
Explanation of key markings	
Explicaciones de los signos clave	
标记说明	
3 Basismaschine	
Basic machine	
Máquina básicas	
基础机器	
3.01 Gehäuseteile	11
Housing sections	
Piezas del cárter	
机身零件	
3.02 Kopfteile	12
Needle head parts	
Piezas de la cabeza	
机头零件	
3.03 Armteile	16
Arm parts	
Piezas del brazo	
机臂零件	
3.04 Grundplattenteile	24
Bedplate parts	
Piezas del cárter	
底板零件	
4 Abweichende Teile der PFAFF 1181-G;1183-G	31
Different parts for PFAFF 1181-G;1183-G	
Piezas de la PFAFF 1181-G;1183-G que son diferentes	
PFAFF 1181-G;1183-G 中有差别的零件	
5 SRP	34
SRP	
SRP	
SRP	
6 Abweichende Teile der PFAFF 3511-2/01	37
Different parts for PFAFF 3511-2/01	
Piezas de la PFAFF 3511-2/01 que son diferentes	
PFAFF 3511-2/01 中有差别的零件	
7 Abweichende Teile der PFAFF 3701-4/11	46
Different parts for PFAFF 3701-4/11	
Piezas de la PFAFF 3701-4/11 que son diferentes	
PFAFF 3701-4/11 中有差别的零件	

	Seite Page Página 页
8 Kanten-Beschneideinrichtung (-731/01)	47
Edge trimmer (-731/01)	
Recortador (-731/01)	
切边器 (-731/01)	
9 Fadenabschneid-Einrichtung (-900/24)	50
Thread trimmer (-900/24)	
Cortahilos (-900/24)	
切线器 (-900/24)	
10 Fadenklemme (-909/14)	53
Thread trapper (-909/14)	
Pinza sujetahilos (-909/14)	
夹线器 (-909/14)	
11 Presserfuß-Automatik (-910/06)	54
Automatic presser foot lifter (-910/06)	
Grupo acondicionador del aire comprimido (-910/06)	
压脚自动提升器 (-910/06)	
12 Verriegelungs-Einrichtung (-911/37)	55
Backtacking mechanism (-911/37)	
Rematador (-911/37)	
锁紧装置 (-911/37)	
13 Spulensfadenvorratswächter (-926/06)	57
Bobbin thread supply monitor (-926/06)	
Detector del hilo de la canilla (-926/06)	
底线余量监视器 (-926/06)	
14 Walzentransport-Einrichtung (-948/26)	58
Puller feed (-948/26)	
Puller (-948/26)	
滚筒送料器 (-948/26)	
15 Wartungseinheit	60
Air filter / lubricator	
Grupo acondicionador del aire comprimido	
保养单元	
16 Elektrische Ausrüstung	
Electrical equipment	
Equipo eléctrico	
电设备	
16.01 Kabelbaum zum Oberteil	61
Cable tree to sewing head	
Mazo de cables para el cabezal	
上部机器电缆束	
16.02 Tastschalter	63
Push-button	
Interruptor pulsador	
按钮开关	
16.03 Oberteilerkennung und Einschaltsperr	64
Sewing head identification and start inhibitor	
Detección de la parte superior y bloqueo de arranque	
上部机器识别和起动闭锁	

	Seite Page Página 页
16.04 Einbaumotor	65
Built-in motor Motor incorporado 内装式电机	
16.05 Motor-Hauptschalter	66
Main switch Interruptor principal 电机主开关	
16.06 Knietaster mit Leitung	66
Knee switch with cable Interruptor de rodillera con cable 带电缆膝键	
16.07 Antrieb	67
Drive Motor 驱动器	
16.08 Steuerungspaket Quick-PicoDrive mit P40 PD	68
Control package Quick-PicoDrive with P40 PD Paquete de control Quick-PicoDrive con P40 PD 控制组件 Quick-PicoDrive 带 P40 PD	
16.09 Steuerungspaket Quick-EcoDrive mit P40 ED-A	70
Control package Quick-EcoDrive with P40 ED-A Paquete de control Quick-EcoDrive con P40 ED-A 控制组件 Quick-EcoDrive 带 P40 ED-A	
16.10 Steuerungspaket Quick-EcoDrive mit P50 ED	72
Control package Quick-EcoDrive with P50 ED Paquete de control Quick-EcoDrive con P50 ED 控制组件 Quick-EcoDrive 带 P50 ED	
16.11 Steuerungspaket Quick-EcoDrive mit P350 ED	74
Control package Quick-EcoDrive with P350 ED Paquete de control Quick-EcoDrive con P350 ED 控制组件 Quick-EcoDrive 带 P350 ED	
16.12 Steuerungspaket Quick-EcoDrive mit P310 ED-A	76
Control package Quick-EcoDrive with P310 ED-A Paquete de control Quick-EcoDrive con P310 ED-A 控制组件 Quick-EcoDrive 带 P310 ED-A	
17 Garnrollenstände	78
Reel stands Portacarretes 线轴支架	
18 Einstellehren	79
Adjustment gauges Calibres de ajuste 设置量规	
19 Teile zur Tischplatte	79
Parts for table top Piezas para el tablero 用于台板的零件	

	Seite Page Página 页
20 Keilriemen V-belt Correa trapezoidal 三角皮带	80
21 Knielüfterteile Knee lifter parts Piezas del alzaprensatelas por rodillera 膝松线器零件	80
22 Optionen Options Opciones 选项	
22.01 Anbausatz für externen Motor..... Mounting kit for external motor Juego de piezas acoplables para motor externo 外部电机安装组件	81
22.02 Absaugeinrichtung (-920/06) Vacuum waste disposal unit (-920/06) Dispositivo de aspiración (-920/06) 吹风装置 (-920/06)	82
23 Schmiermittel-Übersicht Overview of lubricants Tabla de lubricantes 润滑剂一览	83
24 Index (Teilenummern / Seitenzahlen) Index (part numbers / page numbers) Index (números de pieza / números de página) 注脚(零件号/页号)	84
25 Unterklassen-Ausstattung Subclass parts Composición de las subclases 子机型-设备	
25.01 Nähwerkzeuge (PFAFF 1181)..... Gauge parts (PFAFF 1181) Organos de costura (PFAFF 1181) 缝纫工具 (PFAFF 1181)	92
25.02 Nähwerkzeuge (PFAFF 1183)..... Gauge parts (PFAFF 1183) Organos de costura (PFAFF 1183) 缝纫工具 (PFAFF 1183)	95
23.03 Nähwerkzeuge (PFAFF 3511)..... Gauge parts (PFAFF 3511) Organos de costura (PFAFF 3511) 缝纫工具 (PFAFF 3511)	99
23.04 Nähwerkzeuge (PFAFF 3701)..... Gauge parts (PFAFF 3701) Organos de costura (PFAFF 3701) 缝纫工具 (PFAFF 3701)	100

Achtung!



Wir machen ausdrücklich darauf aufmerksam, daß Ersatz- und Zubehörteile, die nicht von uns geliefert werden, auch nicht von uns geprüft und freigegeben sind. Der Einbau und / oder die Verwendung solcher Produkte kann daher u. Umständen konstruktiv vorgegebene Eigenschaften Ihrer Maschine negativ verändern. Für Schäden, die durch die Verwendung von Nicht-Originalteilen entstehen, übernehmen wir keine Haftung!

Caution!



We warn you expressively that spare parts and accessories that are not supplied by us are not tested and released by us. Fitting or using these products may therefore have negative influences on features that depend on the machine design. We are not liable for any damage caused by the use of non-Pfaff parts!

¡Atención!



Se hace observar que en el caso de piezas de recambio y accesorios que no hayan sido suministrados por nosotros, quiere decir que non han sido sometidas por nuestra parte a un control y que no se les ha dado el visto bueno. Por esta razón, el montaje y/o empleo de tales productos puede repercutir negativamente en las características previstas en su máquina. ¡Para los daños que eventualmente pudiesen presentarse al utilizar piezas no originales, no asumimos ninguna garantía!

注意!



我们必须明确指出，所有不是由我们供货的备件和附件都未经我们检查，也没有被我们批准使用。装入和/或使用这些产品可能在一定的情况下会对机器的设计特性造成负面改变。对由于使用非原装件所造成的损失，我们不负任何责任!

- Die Seriennummer der Maschine, für die diese Teileliste Gültigkeit hat, ist auf der Titelseite aufgeführt.
 - Alle Teile sind so abgebildet, wie sie in der Maschine funktionsmäßig zusammengehören.
 - Gestrichelt dargestellte Teile zeigen angrenzende Teile aus anderen Funktionsgruppen.
 - Im oberen Teil der Bildseiten befindet sich eine Gesamtansicht der Maschine .
 - Der Einbauort der dargestellten Teile wird durch eine gerasterte Fläche gekennzeichnet.
 - Einrahmungen auf den Bildseiten zeigen, aus welchen Einzelteilen sich die Gruppenteile zusammensetzen.
 - Die auf den Bildseiten verwendeten Schlüsselzeichen (; 2 ; 3 usw.) sind im Kapitel "Erläuterungen der Schlüsselzeichen" aufgelistet.
-
- The serial number of the machine to which this parts list applies is indicated on the cover page.
 - All parts are illustrated in function groups with the parts which they function together with in the machine.
 - Parts illustrated with broken lines are parts from other function groups which border on the illustrated function group.
 - The above section of the page of illustrations contains a total view of the machine. The place for the installation of the parts pictured here is marked by the grid.
 - The framed-in sections on the illustration pages show the individual parts comprising a group.
 - The key markings used on the illustrated pages (; 2 ; 3 etc.) are listed in the chapter "Explanation of key markings".
-
- El número de serie de la máquina para la cual tiene validez esta lista de piezas va indicado en la página de título.
 - Todas las piezas están ilustradas tal como aparecen en la máquina para su funcionamiento.
 - Las piezas representadas con rayitas muestran piezas colindantes de otros grupos de funciones.
 - En la parte superior de las páginas ilustradas se puede ver una vista en conjunto de la máquina.
 - El lugar de montaje de la pieza representada va caracterizada mediante una superficie reticulada.
 - Los recuadros en las páginas ilustradas indican las piezas individuales de que se componen los grupos.
 - Los signos clave (; 2 ; 3 etc.) empleados en las páginas con ilustraciones van listados en el capítulo "Explicaciones de los signos clave".
-
- 适用于本零件表的机器系列号列在首页上。
 - 所有的零件都按照其在机器中的功能情况合在一起表达。
 - 用虚线表示的零件为相邻功能组中的零件。
 - 图的上部为机器全景。
 - 所示零件的安装部位用影格面表示。
 - 页上的框表示这套组件都由哪些零件所组成。
 - 图页上所使用的标记 (; 2 ; 3 等) 列表在“标记说明”中。

- []** Unterklassenabhängig, Teilenummer siehe Unterklassen-Ausstattung.
Subclass-dependent, for part number see subclass parts listing.
Dependientes de la subclase, para el número de pieza véase "Dotación de subclases".
取决于子机型，零件号见子机型设备。
- A** **Maschinen-Ausstattung für feine Materialien.**
Model A for sewing thin and light-weight materials.
Tipo A para materiales ligeros.
用于薄料的机器设备。
- B** **Maschinen-Ausstattung für mittlere Materialien.**
Model B for sewing thin and medium-weight materials.
Tipo B para materiales semiligeros.
用于中厚料的机器设备。
- C** **Maschinen-Ausstattung für mittelschwere Materialien.**
Model C for sewing medium-heavy materials.
Tipo C para materiales semipesados.
用于中偏厚料的机器设备。
- N** **Stichlänge 6,0 mm.**
Stitch length 6.0 mm.
Largo de puntada 6,0 mm
针距6.0 mm。
- 3/1** **Gesichert mit Loctite.**
Secured with loctite.
Asegurado con Loctite.
用 Loctite 粘胶固定。
- 3/3** **Selbstklebende Folie**
Self-adhesive foil
Hoja autoadhesiva
自粘式薄膜
- 3/4** **Selbstklebend**
Self-adhesive
Autoadhesivo
自粘的
- 6** **Nadeldicke und Spitzenform bei Bestellung angeben.**
Needle size and style of point to be stated on order.
Grosor de aguja y forma de la punta, indíquese en los pedidos.
在订货时给出针厚和针尖型式。
- 27/5** **Eingeklammerte Zahl = Länge in mm.**
Number in brackets = length in mm.
Cifra entre paréntesis = largura en mm.
被括起的数字=长度，单位mm。
- 27/12** **Eingeklammerte Zahl = Durchmesser x breite in mm.**
Number in brackets = diameter x width in mm.
Cifra entre paréntesis = diámetro x anchura en mm.
被括起的数字=直径 x 宽度，单位 mm。
- 28** **Sonderausführung**
Special version
Tipo especial
特殊款式

- 35/1** Bei Montage vernieten.
To be riveted after assembly.
Remáchese después del montaje.
装配时铆接
- 38/7** Kunststoffbeschichtet
Plastic-coated
Con revestimiento de plástico
塑料涂层的
- 38/8** Gezahnt
Toothed
Dentado
帽形齿的
- 38/9** Gerändelt
Knurled
Moleteado
滚花的
- 40/1** Füllen mit 28-011 201-44; Bestellnummer siehe Seite 83.
Top up with 28-011 201-44; for part number see page 83.
Rellene con 28-011 201-44; para el número de pedido véase la página 83.
注油用 28-011 201-44; 订货号见 83页。
- 40/2** Tränken mit 28-011 201-44; Bestellnummer siehe Seite 83.
Grease with 28-011 201-44; for part number see page 83.
Engrase con grasa 28-011 201-44; para el número de pedido véase la página 83.
浸油用 28-011 201-44; 订货号见 83 页。
- 40/3** Fetten mit 28-011 202-47; Bestellnummer siehe Seite 83.
Grease with 28-011 202-47; for part number see page 83.
Engrase con grasa 28-011 202-47; para el número de pedido véase la página 83.
上脂用 28-011 202-47; 订货号见 83 页。
- 40/5** Ölen mit 28-011 201-44; Bestellnummer siehe Seite 83.
Oil with 28-011 201-44; for part number see page 83.
Lubrifique con grasa 28-011 201-44; para el número de pedido véase la página 83.
上油用 28-011 201-44; 订货号见 83 页。
- 40/13** Fetten mit 28-011 202-05; Bestellnummer siehe Seite 83.
Grease with 28-011 202-05; for part number see page 83.
Graisser avec de la graisse 28-011 202-05; n° de commande, voir page 83.
上脂用 28-011 202-05; 订货号见 83 页。
- 90/1** Für Wechselstrom
For single-phase A.C.
Para corriente alterna monofásica
适用于交流电
- 90/110** Zum Bundnähen im Nahtschatten.
For sink-stitching.
Para respuntar pretinas con "puntas invisibles".
用于在接缝处缝裤腰接缝
- 90/111** Zum Bunddurchsteppen.
For top-stitching waistbands.
Para bien sobrecoser pretinas.
用于裤腰绗缝
- 96** Länge angeben.
State length.
Indíquese la largura.
给出长度。

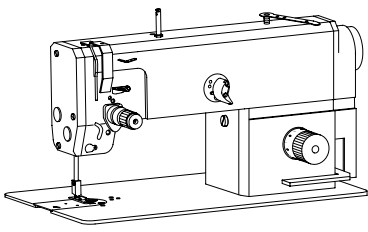

Gehäuseteile
Housing sections
Piezas del cárter
机身零件

PFAFF 1181;1181- D
PFAFF 1183;1183- D

3.01

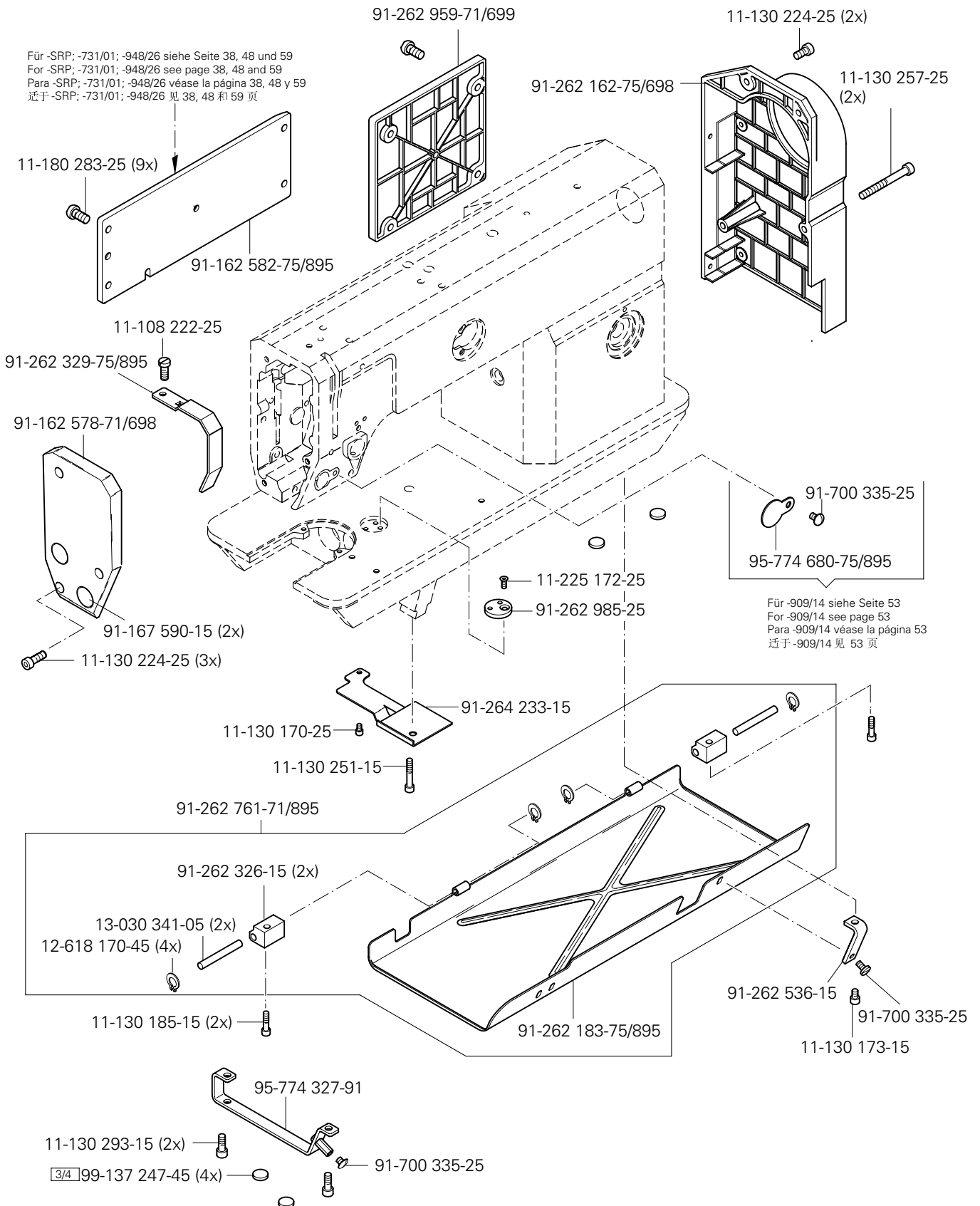

3.02

Kopfteile Needle head parts Piezas de la cabeza 机头零件

PFAFF 1181;1181- D
PFAFF 1183;1183- D

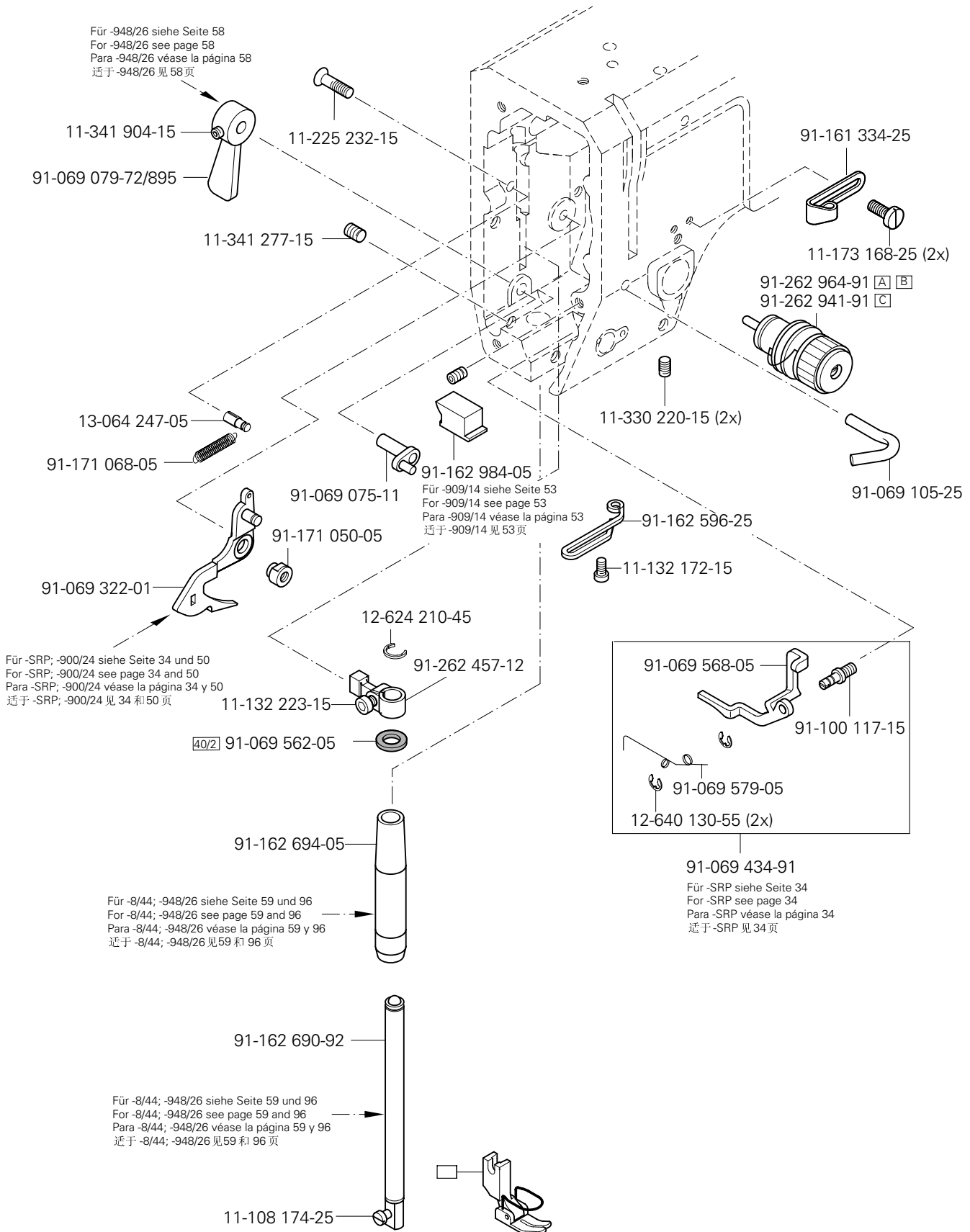
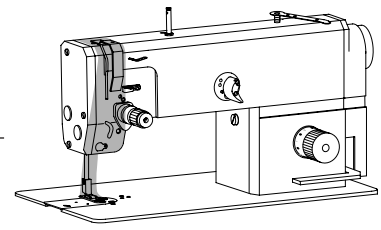

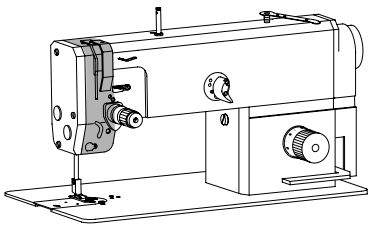

Kopfteile
Needle head parts
Piezas de la cabeza
机头零件

PFAFF 1181;1181- D
PFAFF 1183;1183- D

3.02

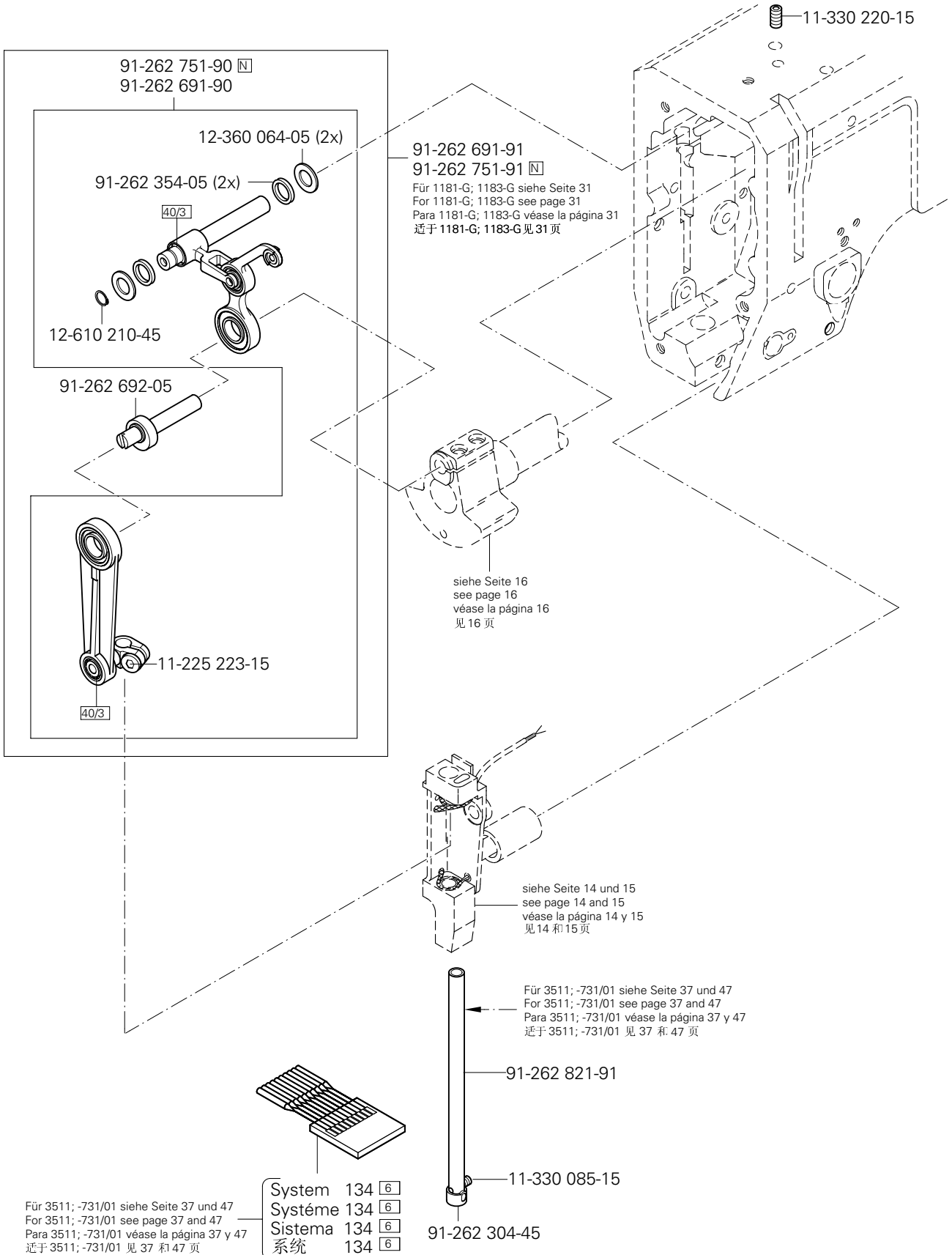

3.02

Kopfteile
Needle head parts
Piezas de la cabeza
机头零件

PFAFF 1181;1181-D

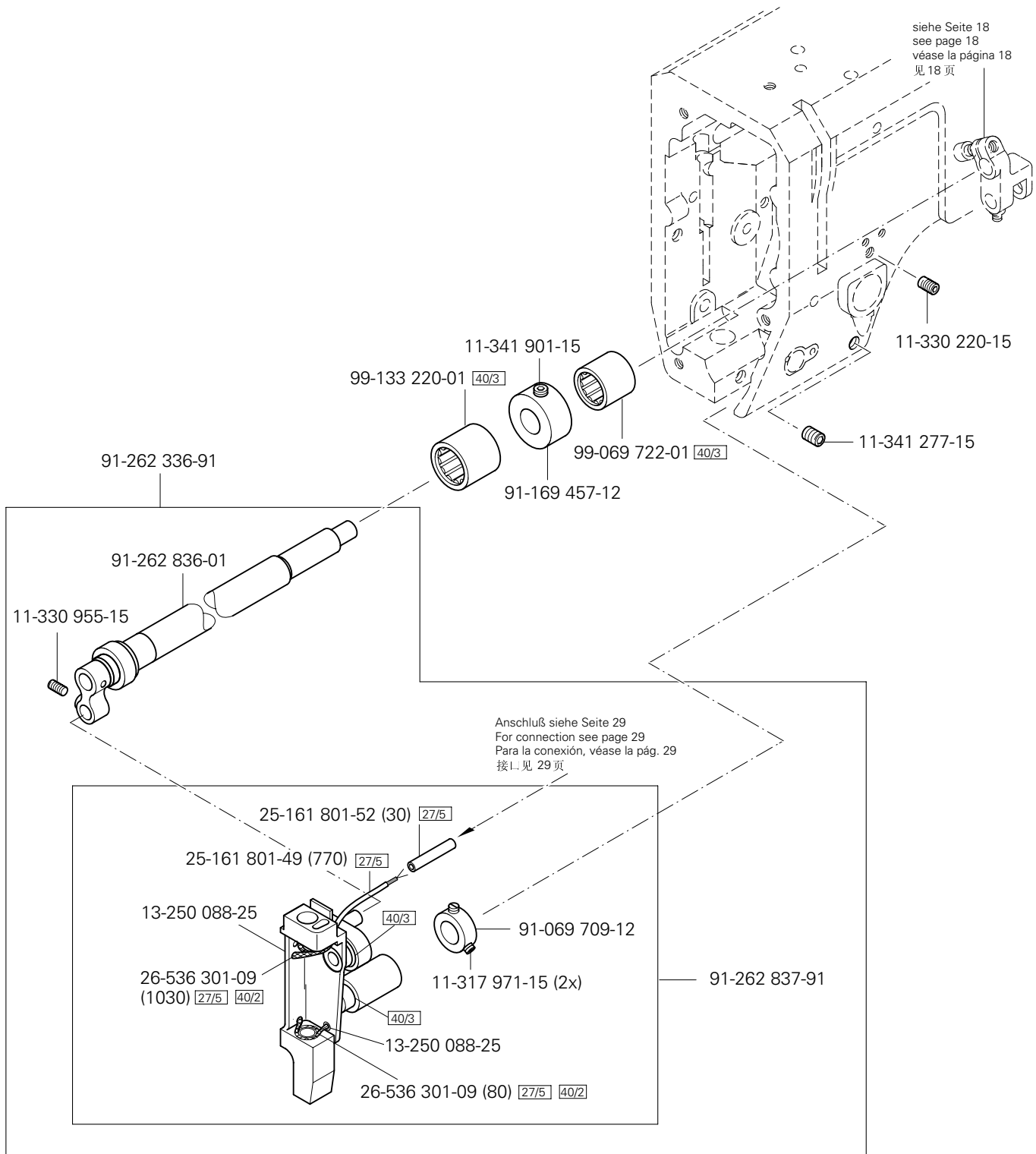
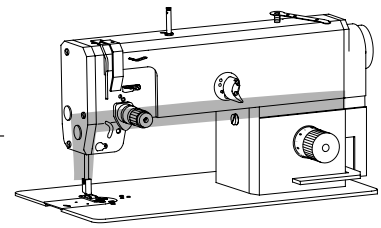

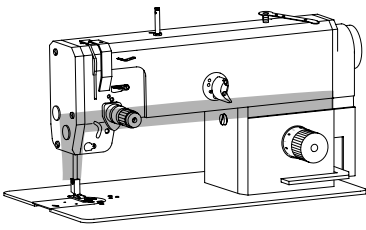

Kopfteile
 Needle head parts
 Piezas de la cabeza
 机头零件

PFAFF 1183;1183- D

3.02

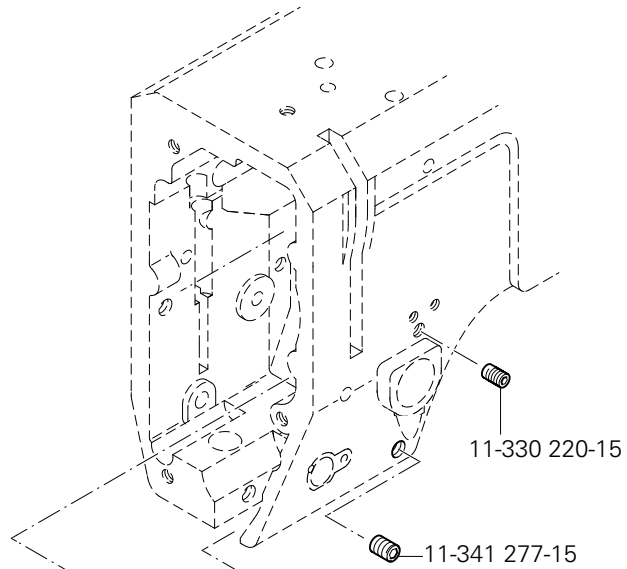

siehe Seite 13
 see page 13
 véase la página 13
 见13页

Anschluß siehe Seite 29
 For connection see page 29
 Para la conexión, véase la pág. 29
 接1 见 29 页

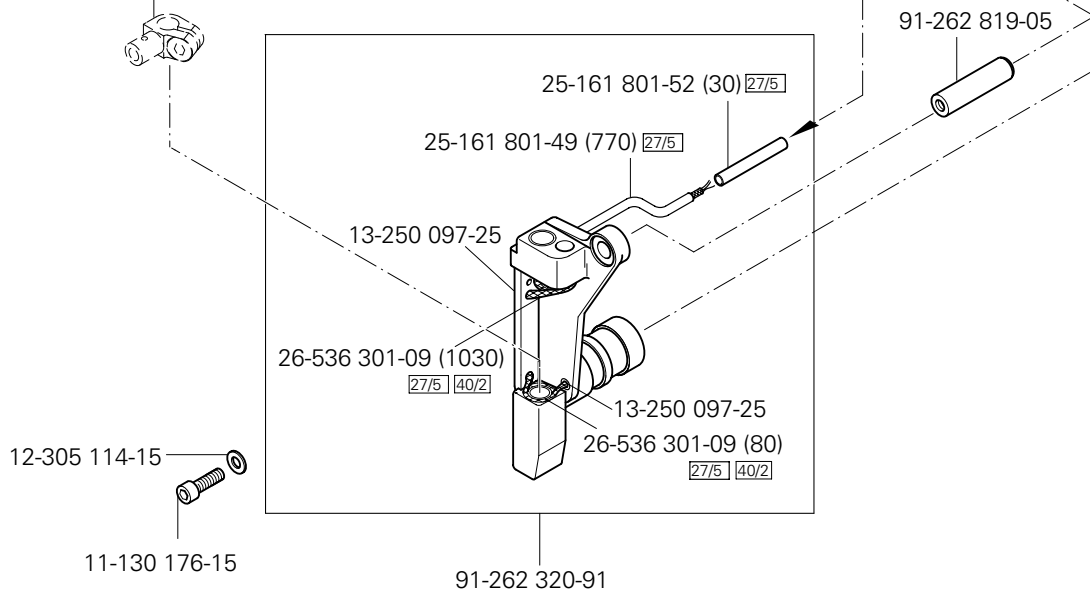

3.03

Armteile
 Arm parts
 Piezas del brazo
 机臂零件

PFAFF 1181;1181- D
 PFAFF 1183;1183- D

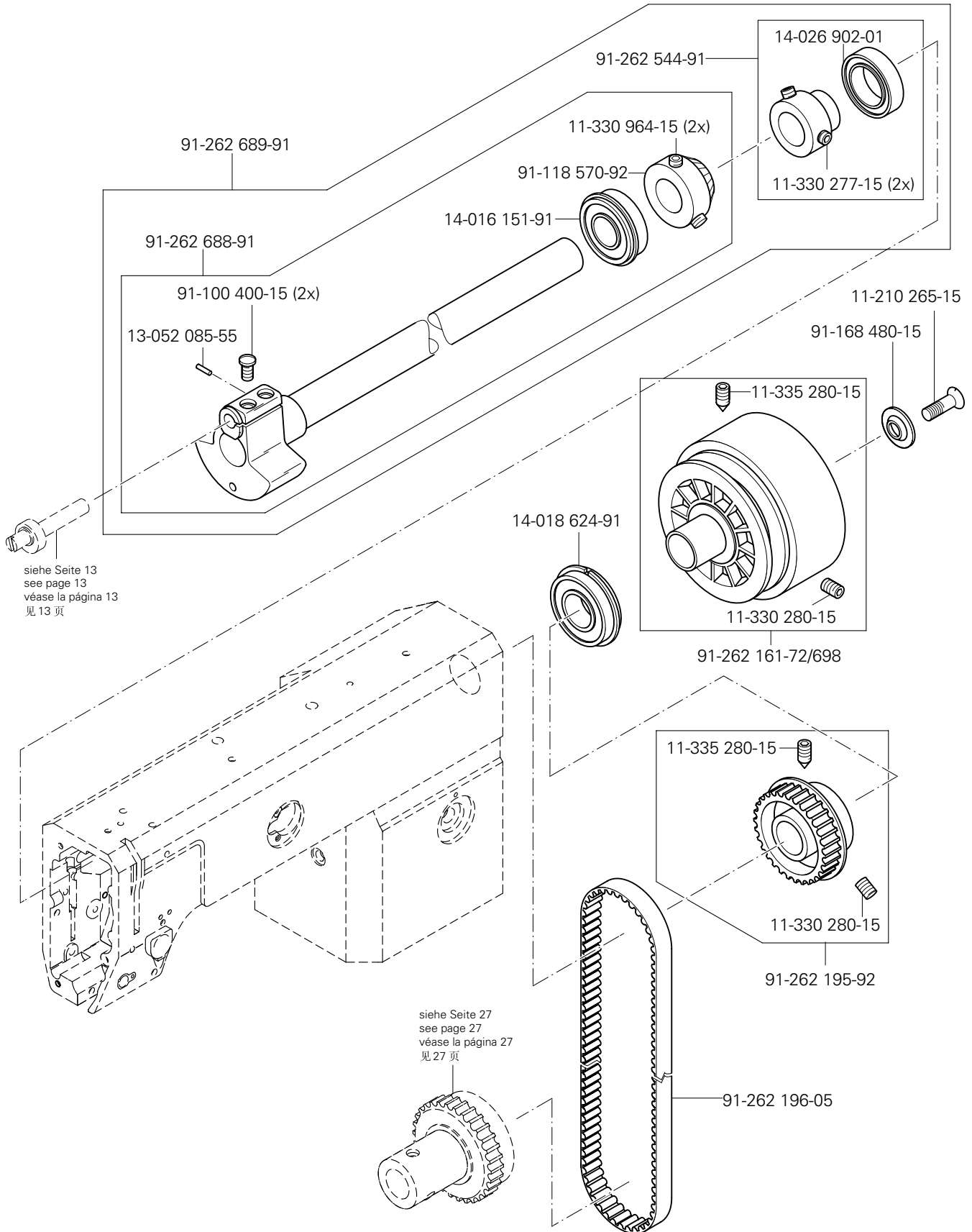
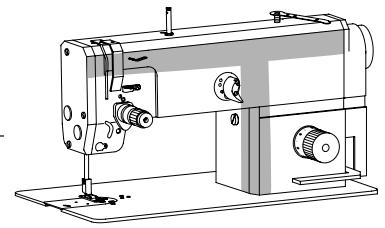

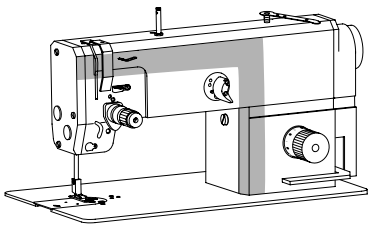

Armteile
 Arm parts
 Piezas del brazo
 机臂零件

PFAFF 1181;1181- D
 PFAFF 1183;1183- D

3.03

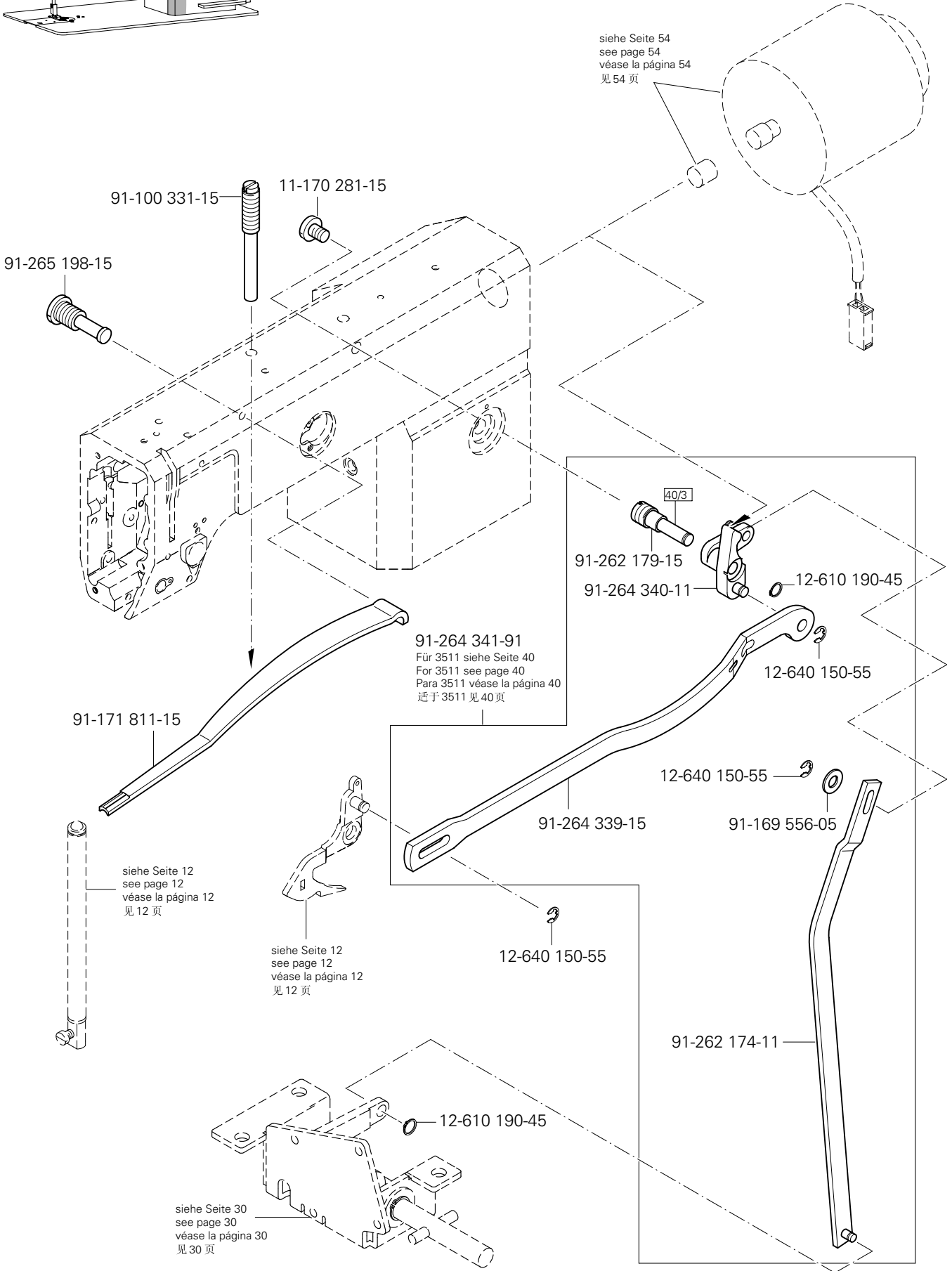

3.03

Armteile
 Arm parts
 Piezas del brazo
 机臂零件

PFAFF 1181;1181-D

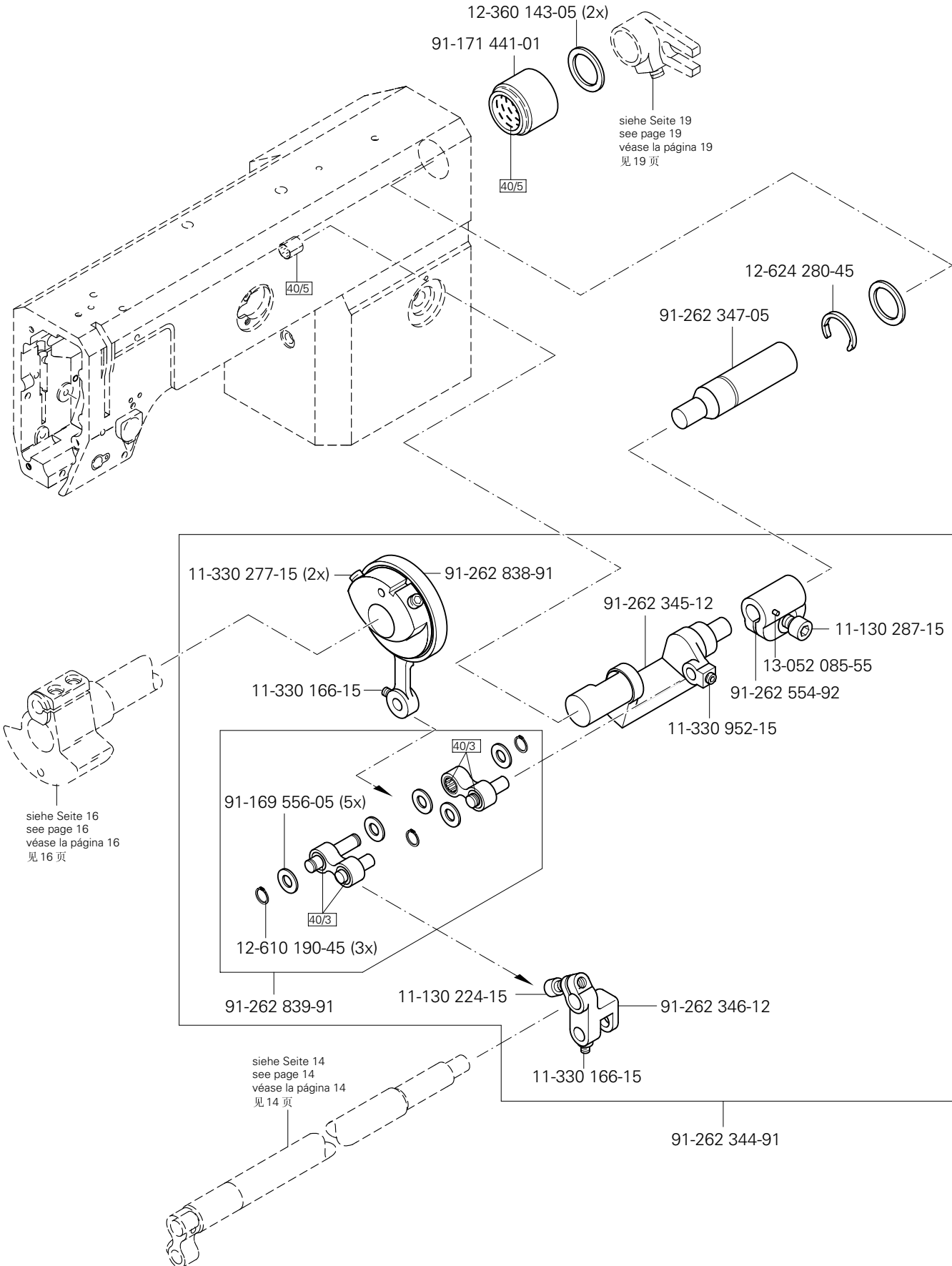
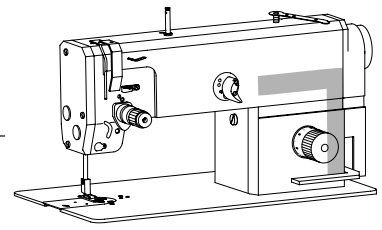

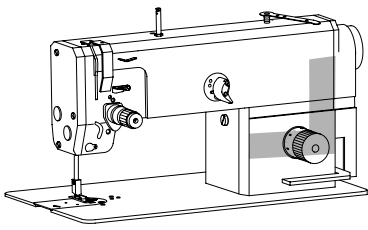

Armteile
 Arm parts
 Piezas del brazo
 机臂零件

PFAFF 1181;1181- D

3.03

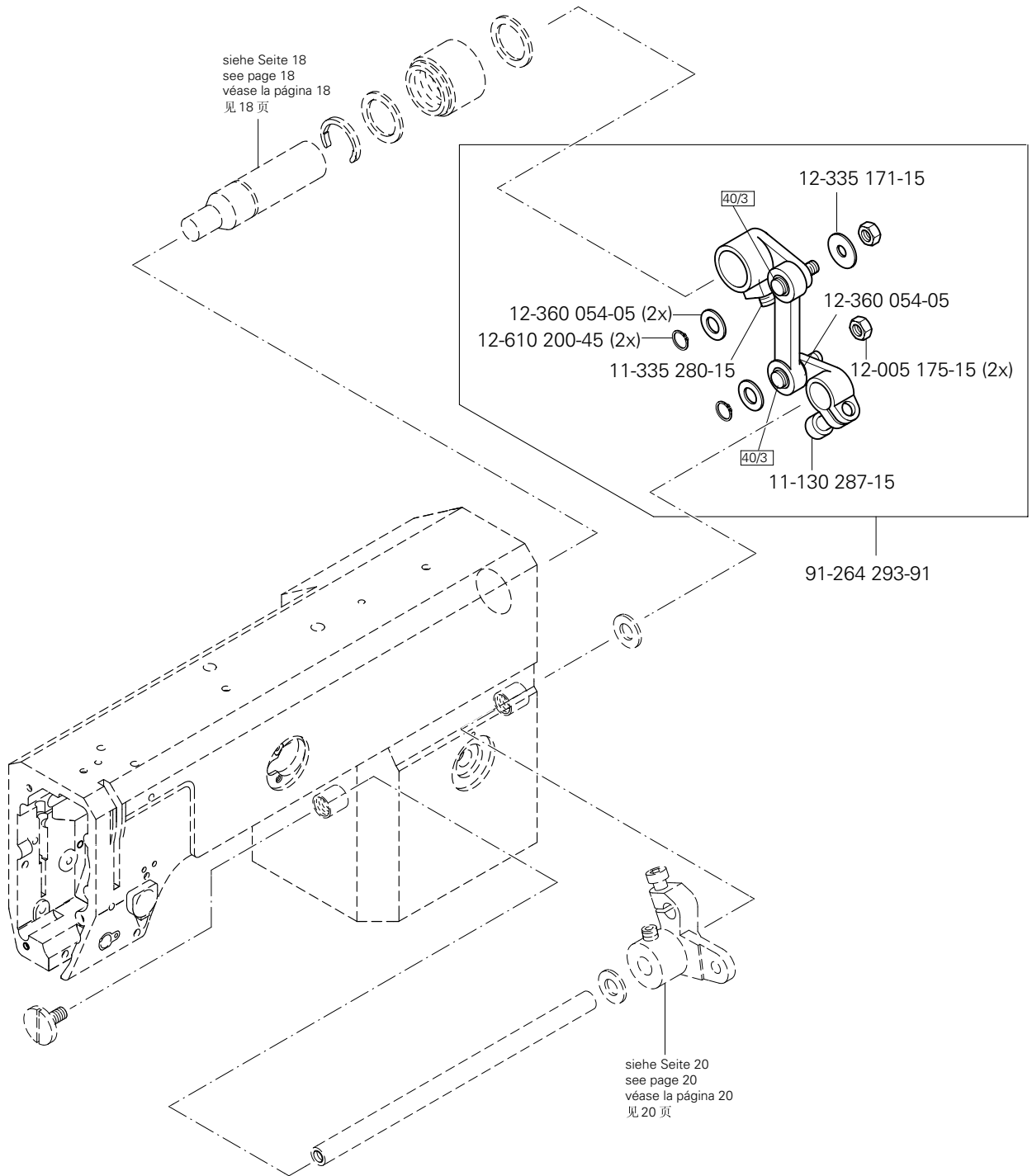

3.03

Armteile
 Arm parts
 Piezas del brazo
 机臂零件

PFAFF 1181;1181- D
 PFAFF 1183;1183- D

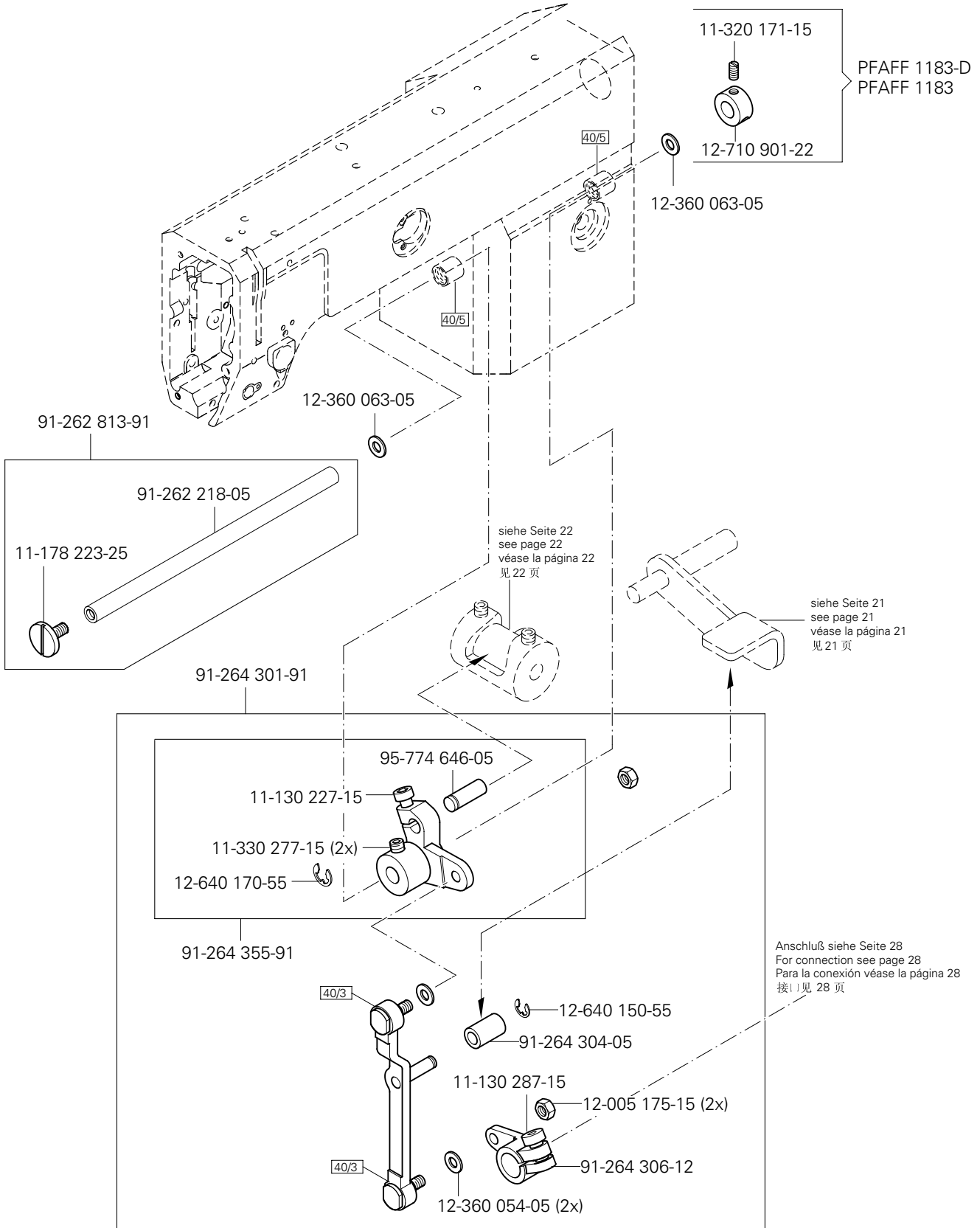
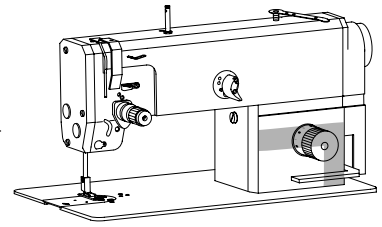

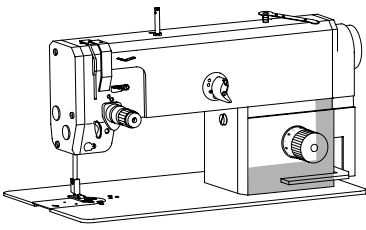

Armteile
 Arm parts
 Piezas del brazo
 机臂零件

PFAFF 1181;1181- D
 PFAFF 1183;1183- D

3.03

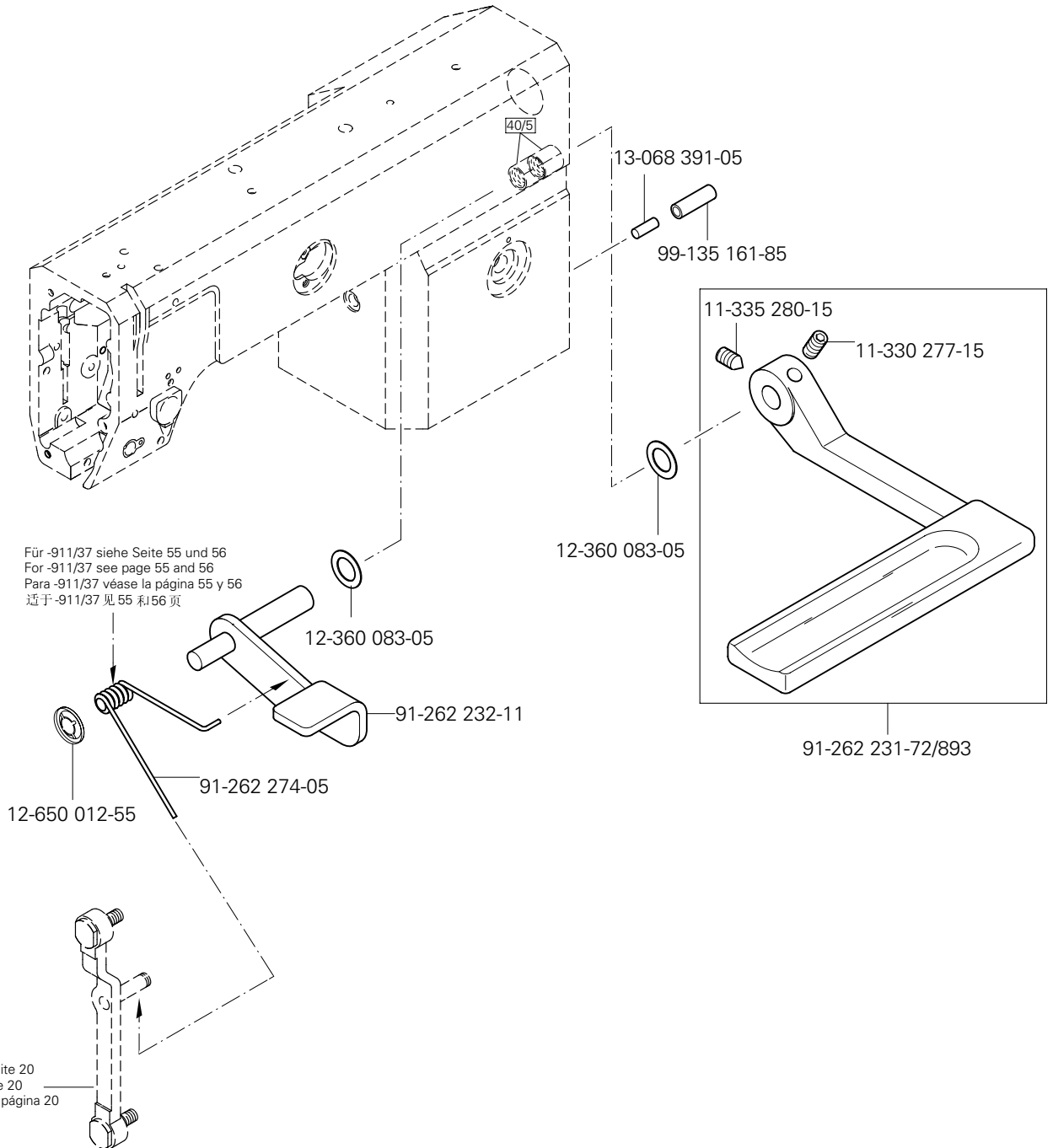

3.03

Armteile
 Arm parts
 Piezas del brazo
 机臂零件

PFAFF 1181;1181- D
 PFAFF 1183;1183- D

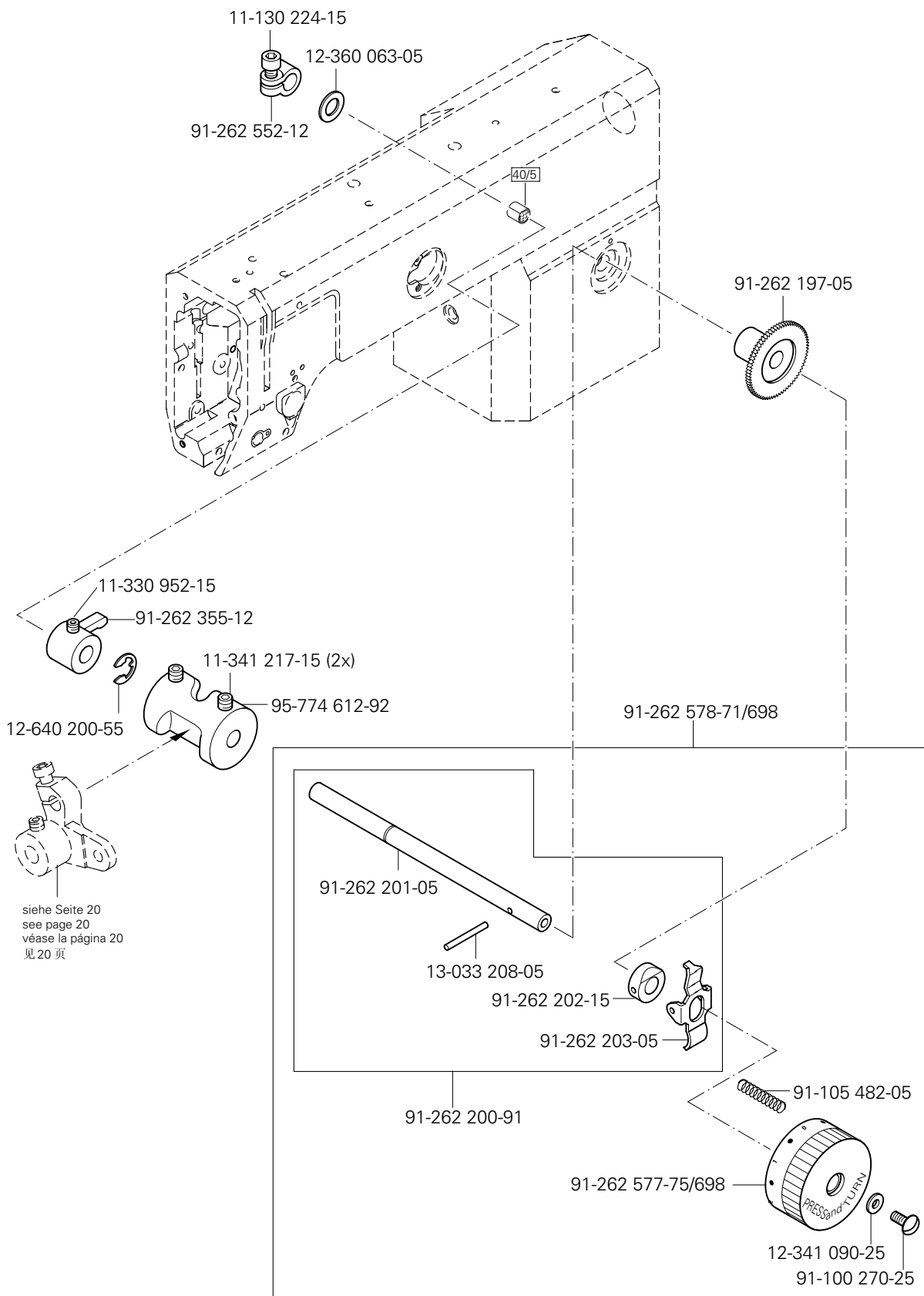
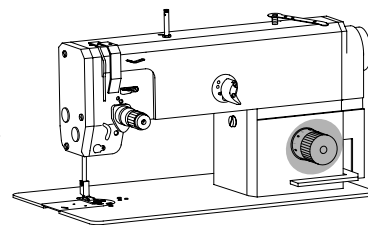

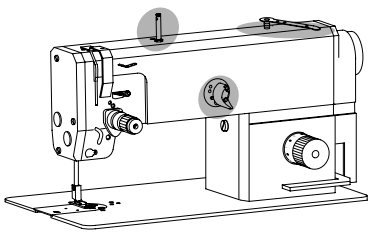

Armteile
 Arm parts
 Piezas del brazo
 机臂零件

PFAFF 1181;1181- D
 PFAFF 1183;1183- D

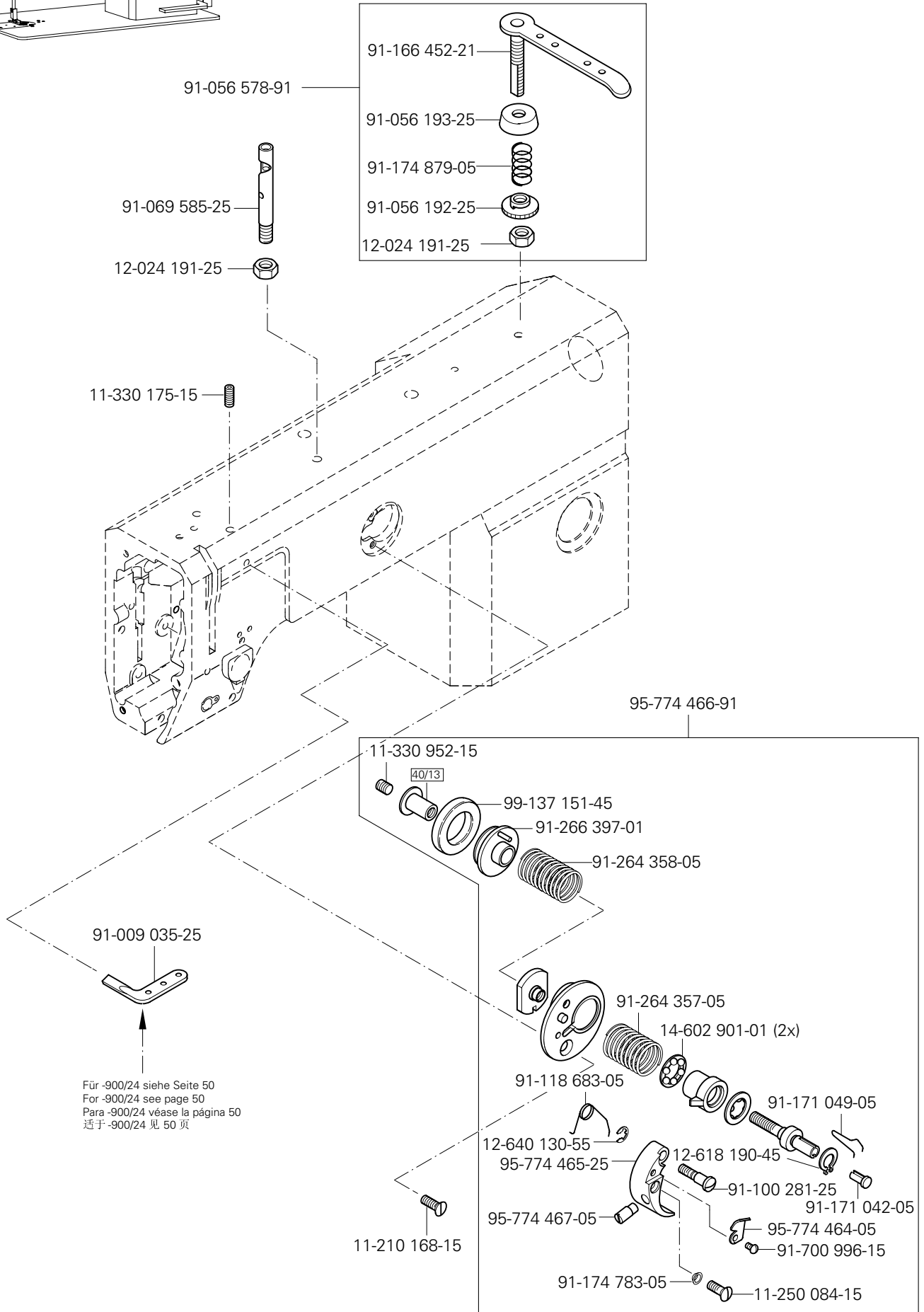

3.04

Grundplattenteile
Bedplate parts
Piezas del cárter
底板零件

PFAFF 1181;1181- D
PFAFF 1183;1183- D

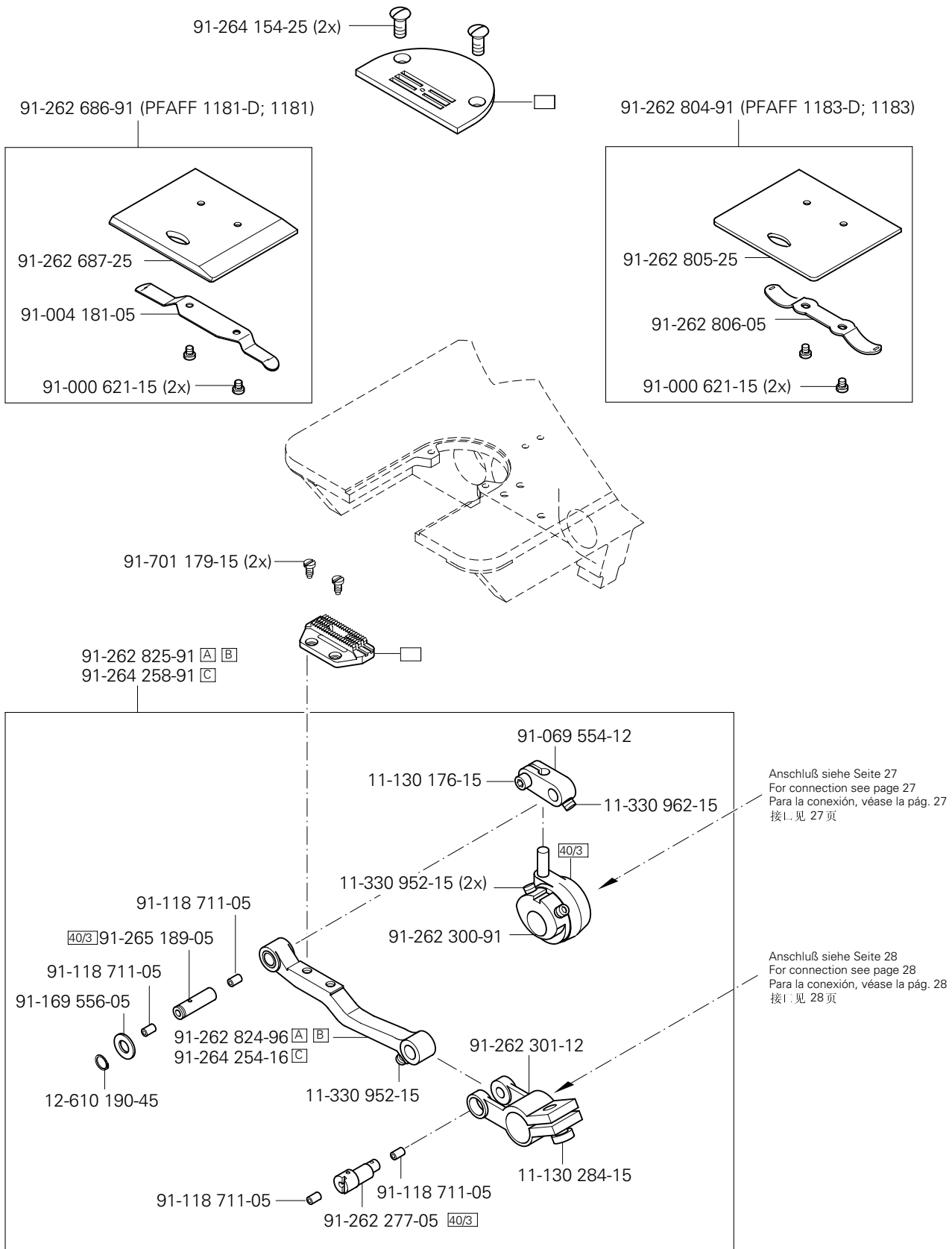
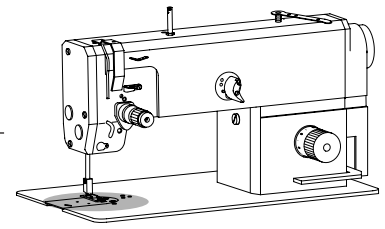

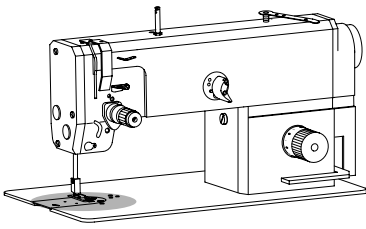

Grundplattenteile
Bedplate parts
Piezas del cárter
底板零件

PFAFF 1181- D
PFAFF 1183- D

3.04

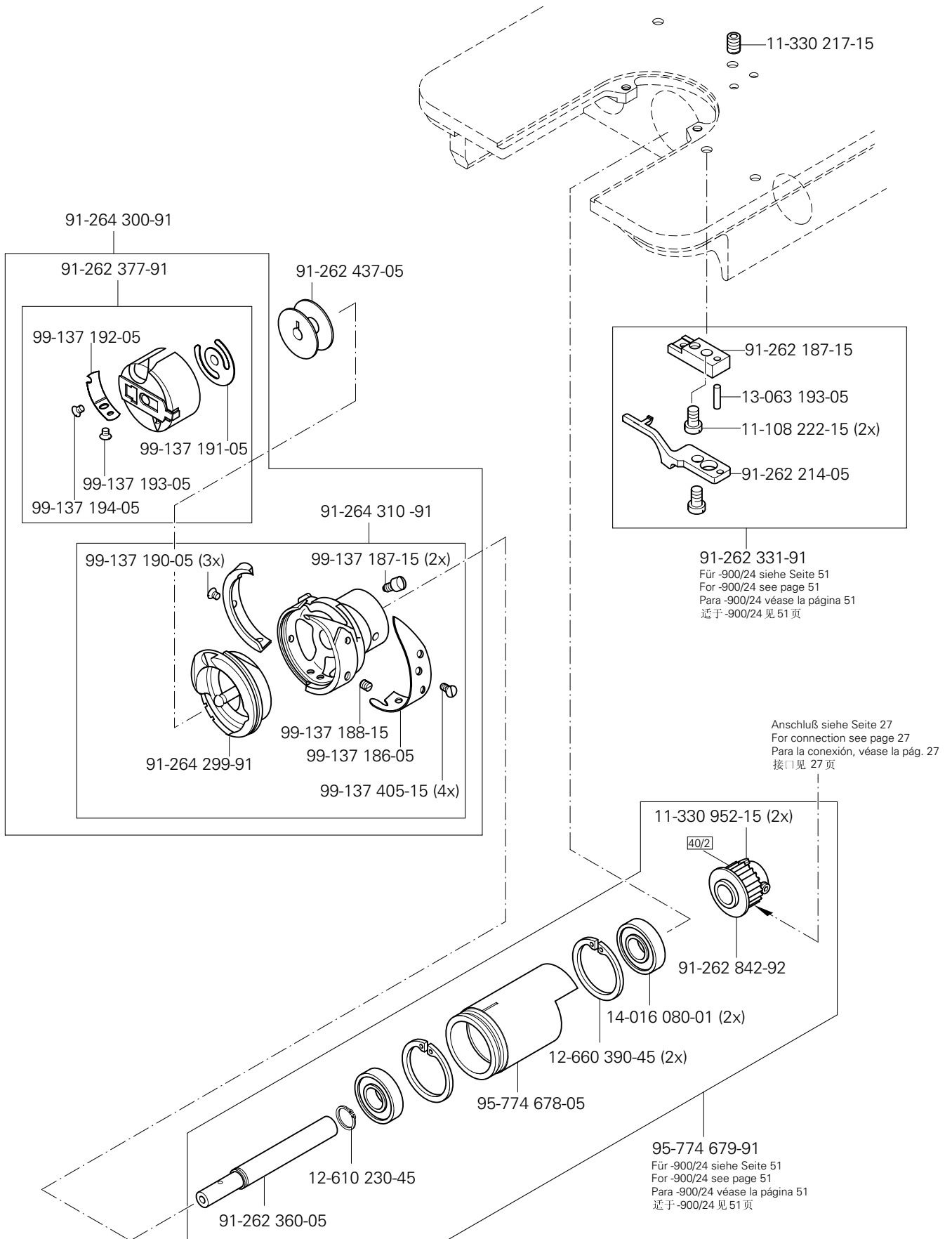

3.04

Grundplattenteile Bedplate parts Piezas del cárter 底板零件

PFAFF 1181
PFAFF 1183

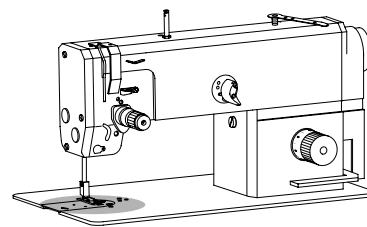

91-262 250-91 **A** **B**

Für 1181-G; 1183-G siehe Seite 32
For 1181-G; 1183-G see page 32
Para 1181-G; 1183-G véase la página 32
适于 1181-G; 1183-G 见 32 页

91-262 437-05

Für 1181-G; 1183-G siehe Seite 32
For 1181-G; 1183-G see page 32
Para 1181-G; 1183-G véase la página 32
适于 1181-G; 1183-G 见 32 页

91-264 383-91 **C**

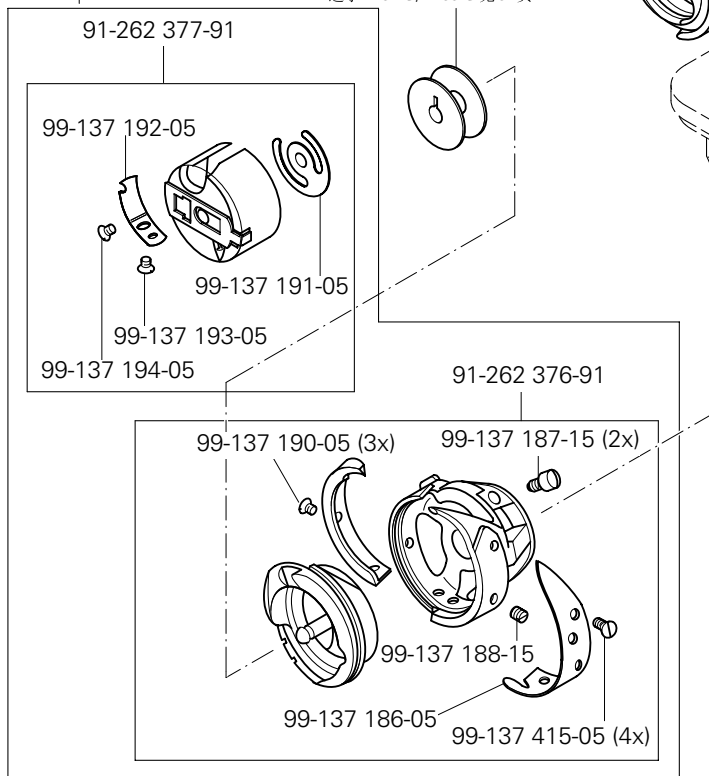
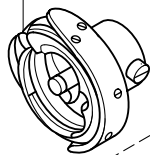

11-330 217-15

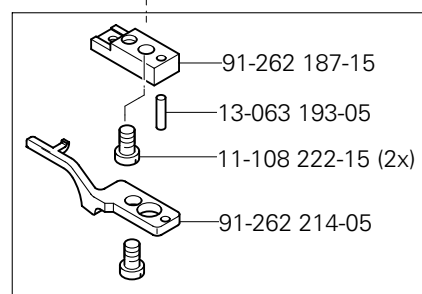

91-262 331-91

Für -900/24 siehe Seite 51
For -900/24 see page 51
Para -900/24 véase la página 51
适于 -900/24 见 51 页

Anschluß siehe Seite 27
For connection see page 27
Para la conexión, véase la pág. 27
接! 见 27 页

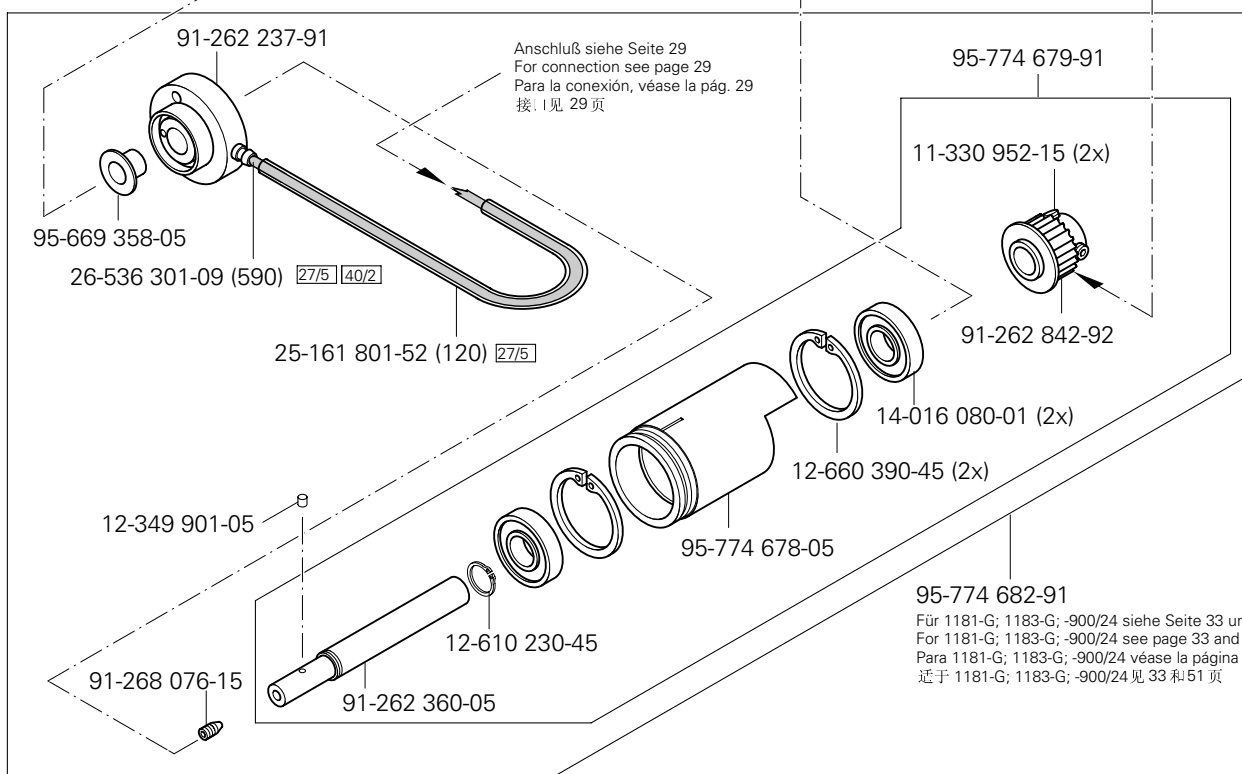

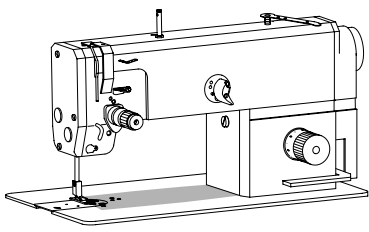

Grundplattenteile
Bedplate parts
Piezas del cárter
底板零件

PFaff 1181;1181- D
PFaff 1183;1183- D

3.04

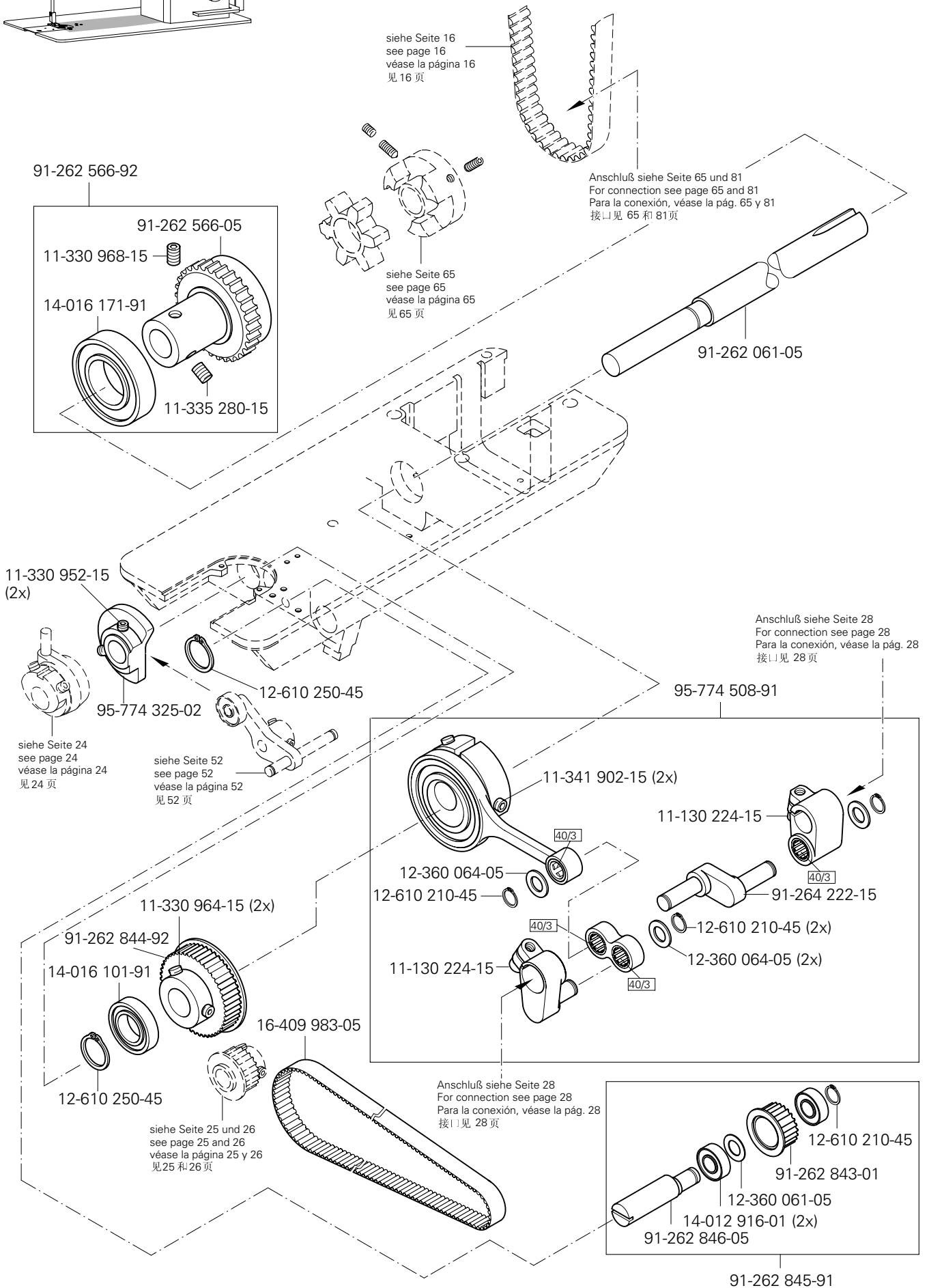

3.04

Grundplattenteile
Bedplate parts
Piezas del cárter
底板零件

PFAFF 1181;1181- D
PFAFF 1183;1183- D

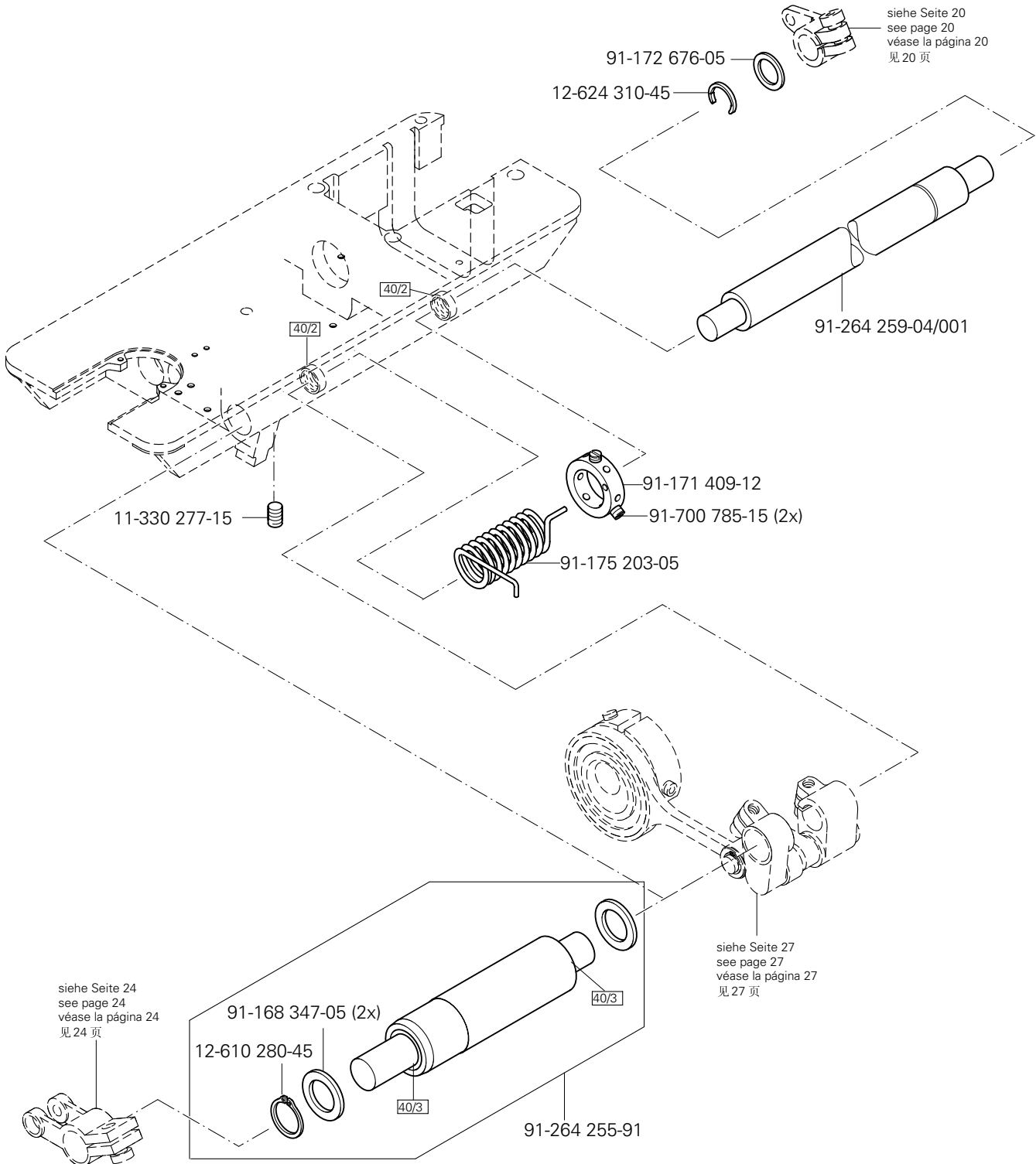
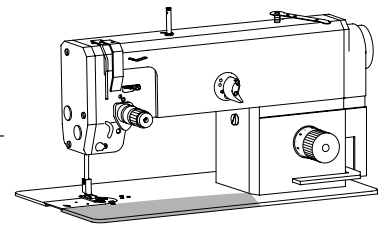

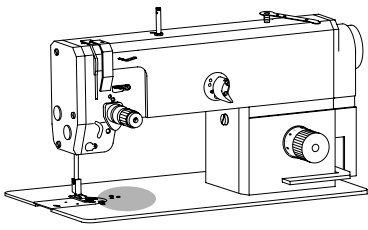

Grundplattenteile
 Bedplate parts
 Piezas del cárter
 底板零件

PFAFF 1181
 PFAFF 1183

3.04

siehe Seite 14 und 15
 see page 14 and 15
 véase la página 14 y 15
 见14和15页

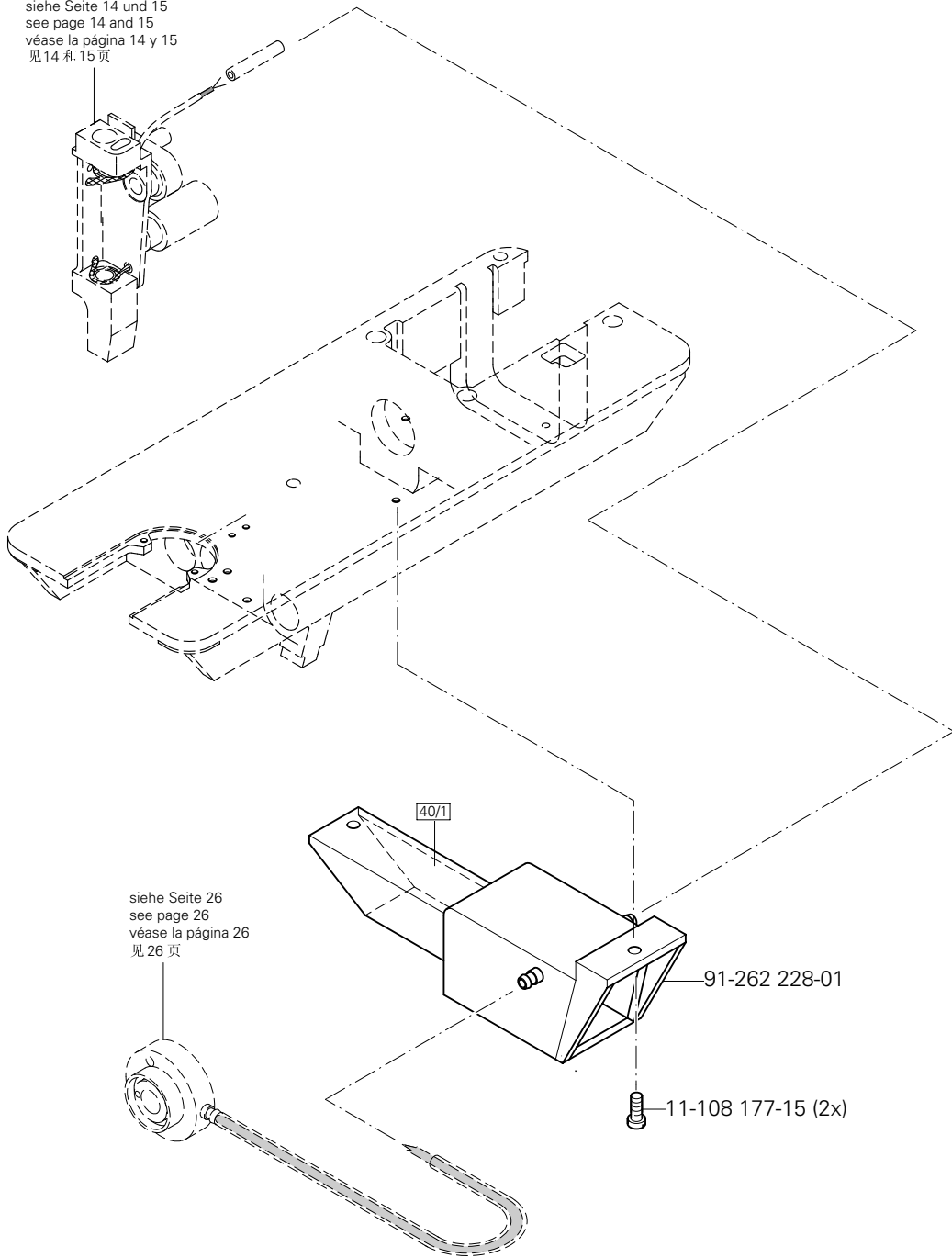

siehe Seite 26
 see page 26
 véase la página 26
 见26页

3.04

Grundplattenteile
Bedplate parts
Piezas del cárter
底板零件

PFAFF 1181;1181- D
PFAFF 1183;1183- D

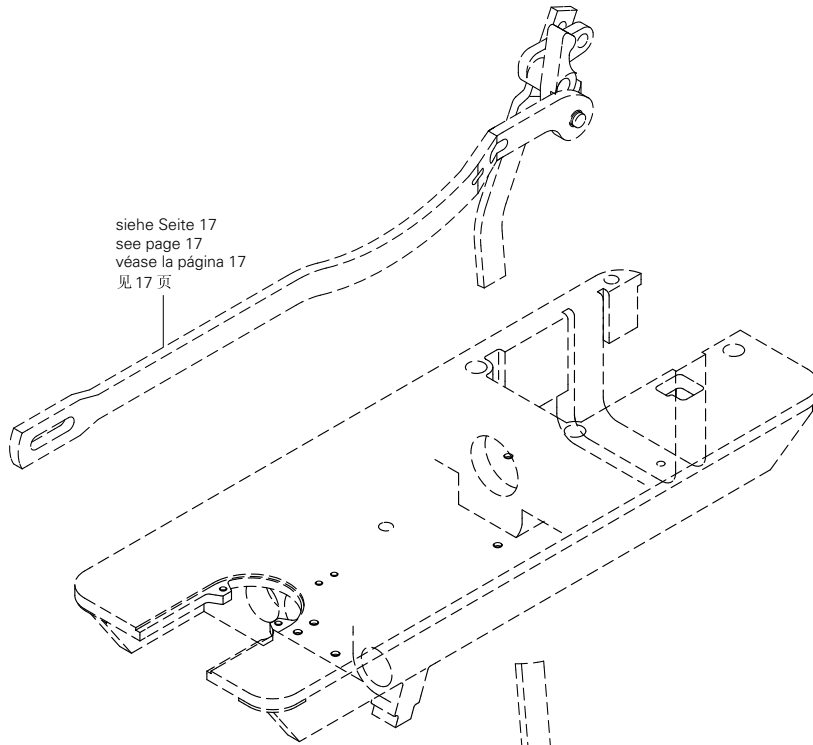
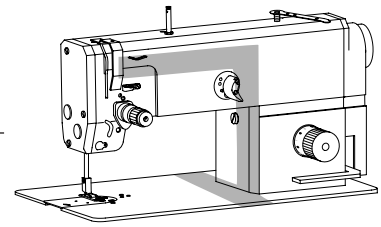

siehe Seite 17
see page 17
véase la página 17
见 17 页

91-262 680-91

91-262 573-05

91-262 465-15

91-262 677-12

11-330 952-15

12-710 904-12

11-130 224-15

11-330 232-15 (2x)

12-305 264-15

12-610 230-45

12-024 171-15 (2x)

91-262 164-12

11-130 287-15 (2x)

Anschluß siehe Seite 80
For connection see page 80
Para la conexión, véase la pág. 80
接 1 见 80 页

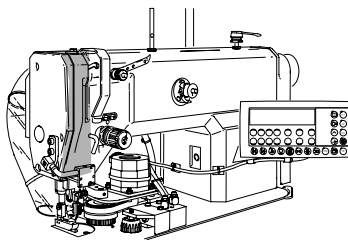

Abweichende Teile der PFAFF 1181-G;1183-G
 Different parts for PFAFF 1181-G;1183-G
 Piezas de la PFAFF 1181-G;1183-G que son diferentes
 PFAFF 1181-G;1183-G 中有差别的零件

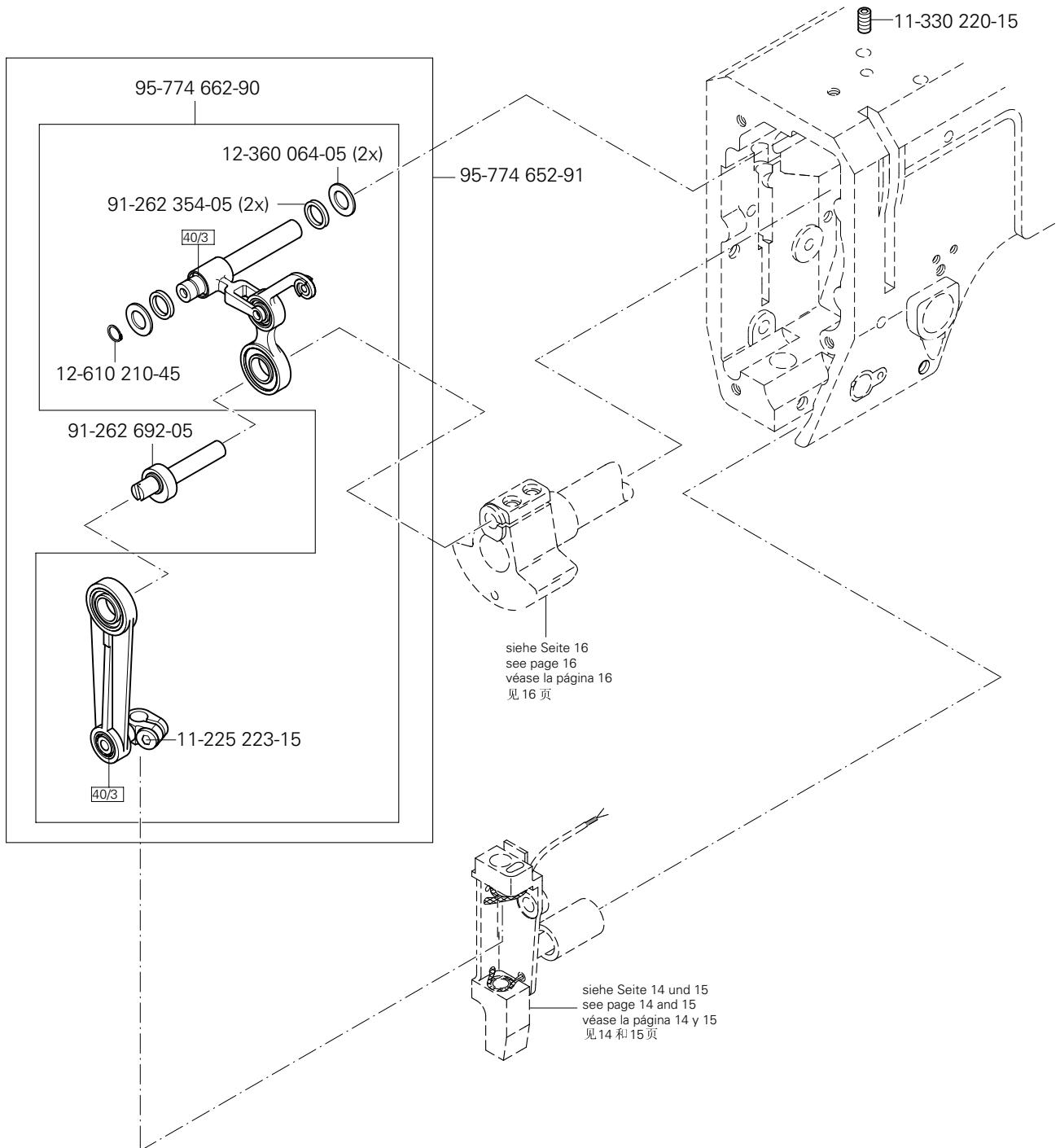

4

Abweichende Teile der PFAFF 1181-G;1183-G
 Different parts for PFAFF 1181-G;1183-G
 Piezas de la PFAFF 1181-G;1183-G que son diferentes
 PFAFF 1181-G;1183-G 中有差别的零件

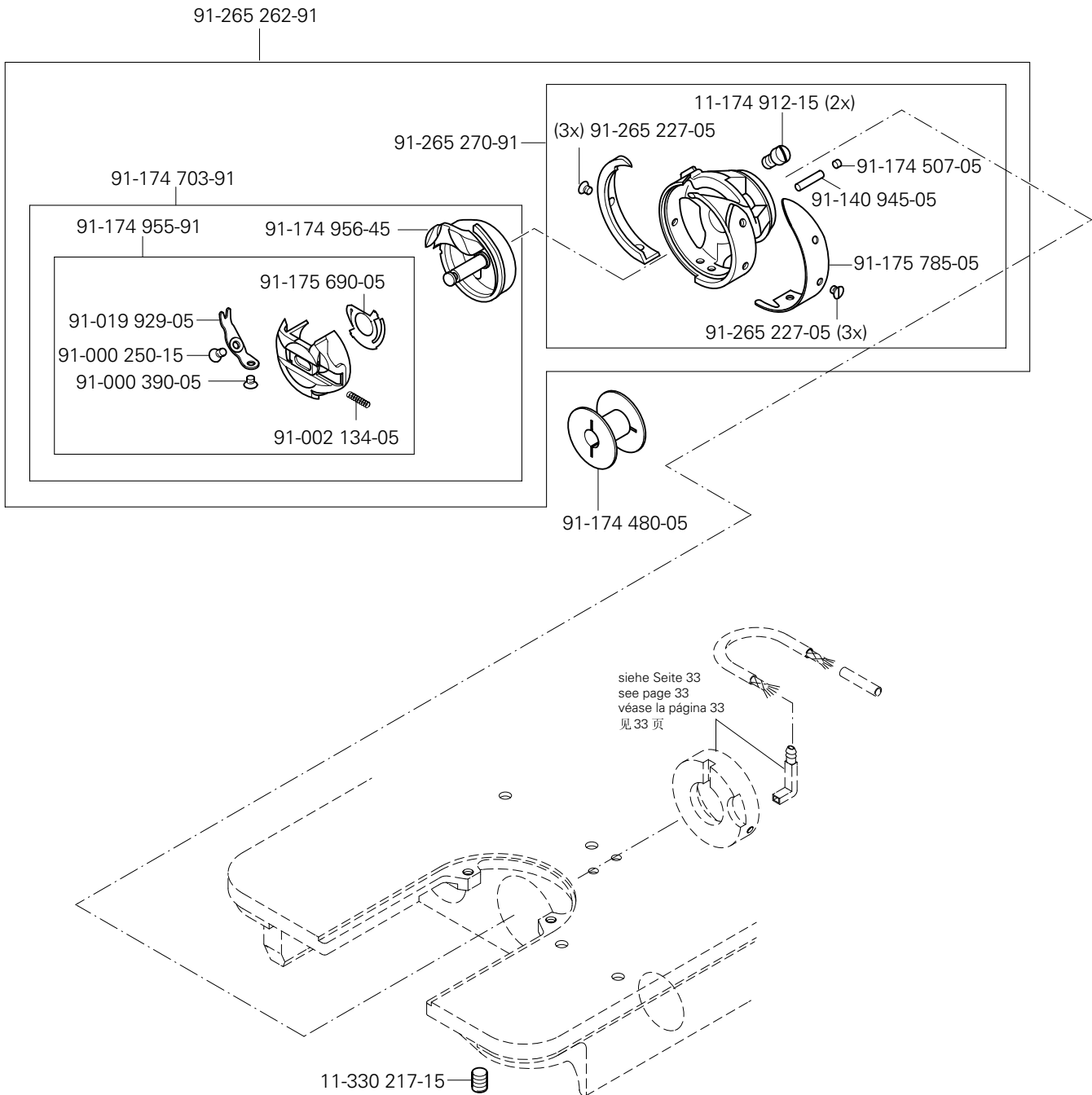
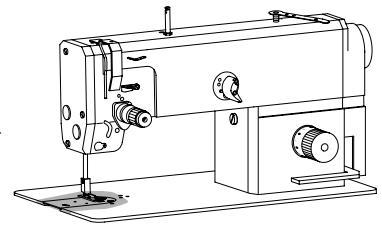

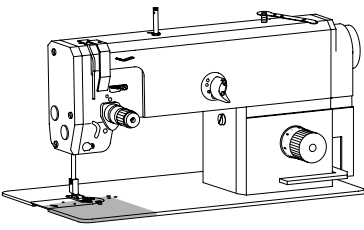

Abweichende Teile der PFAFF 1181-G;1183-G
 Different parts for PFAFF 1181-G;1183-G
 Piezas de la PFAFF 1181-G;1183-G que son diferentes
 PFAFF 1181-G;1183-G 中有差别的零件

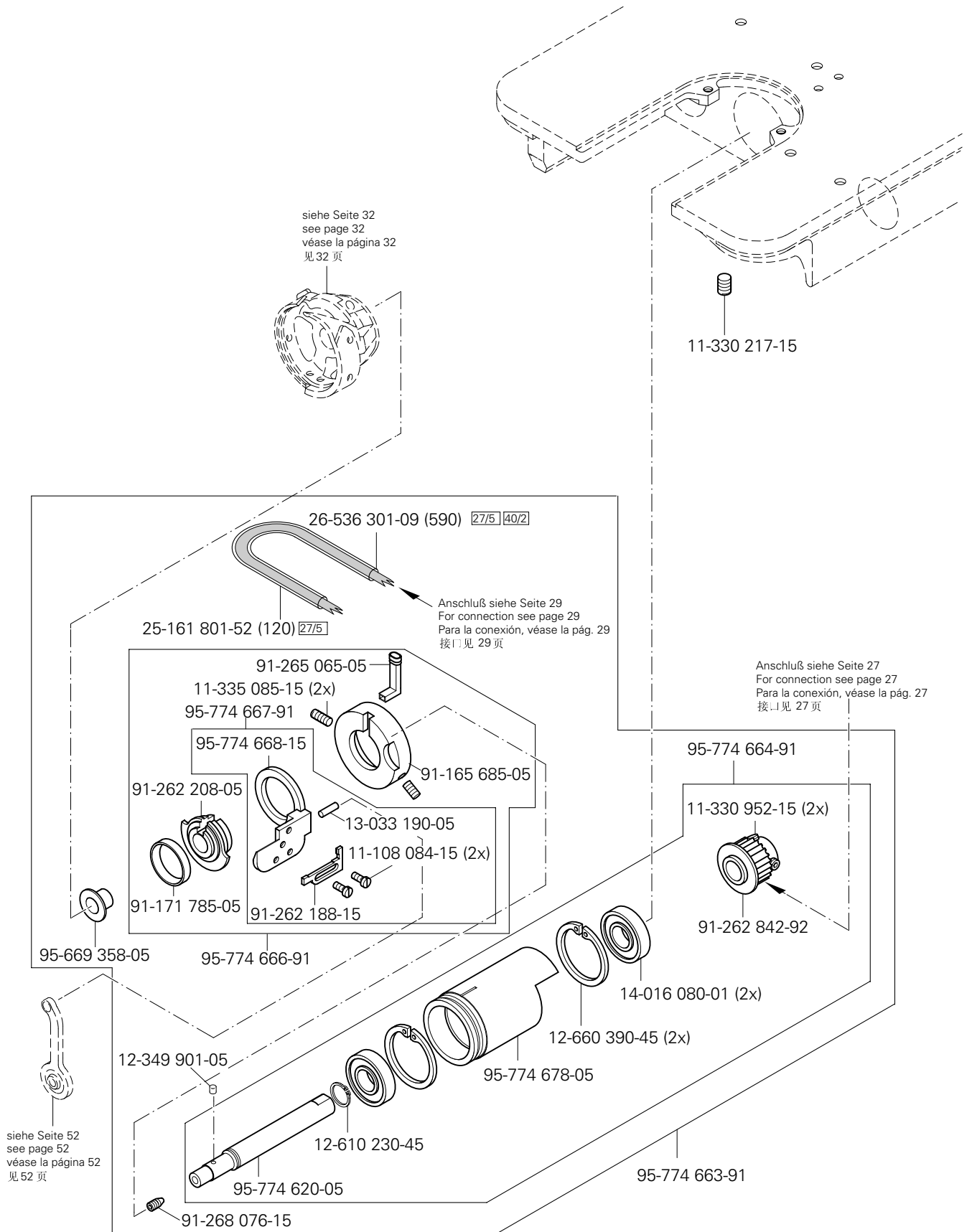

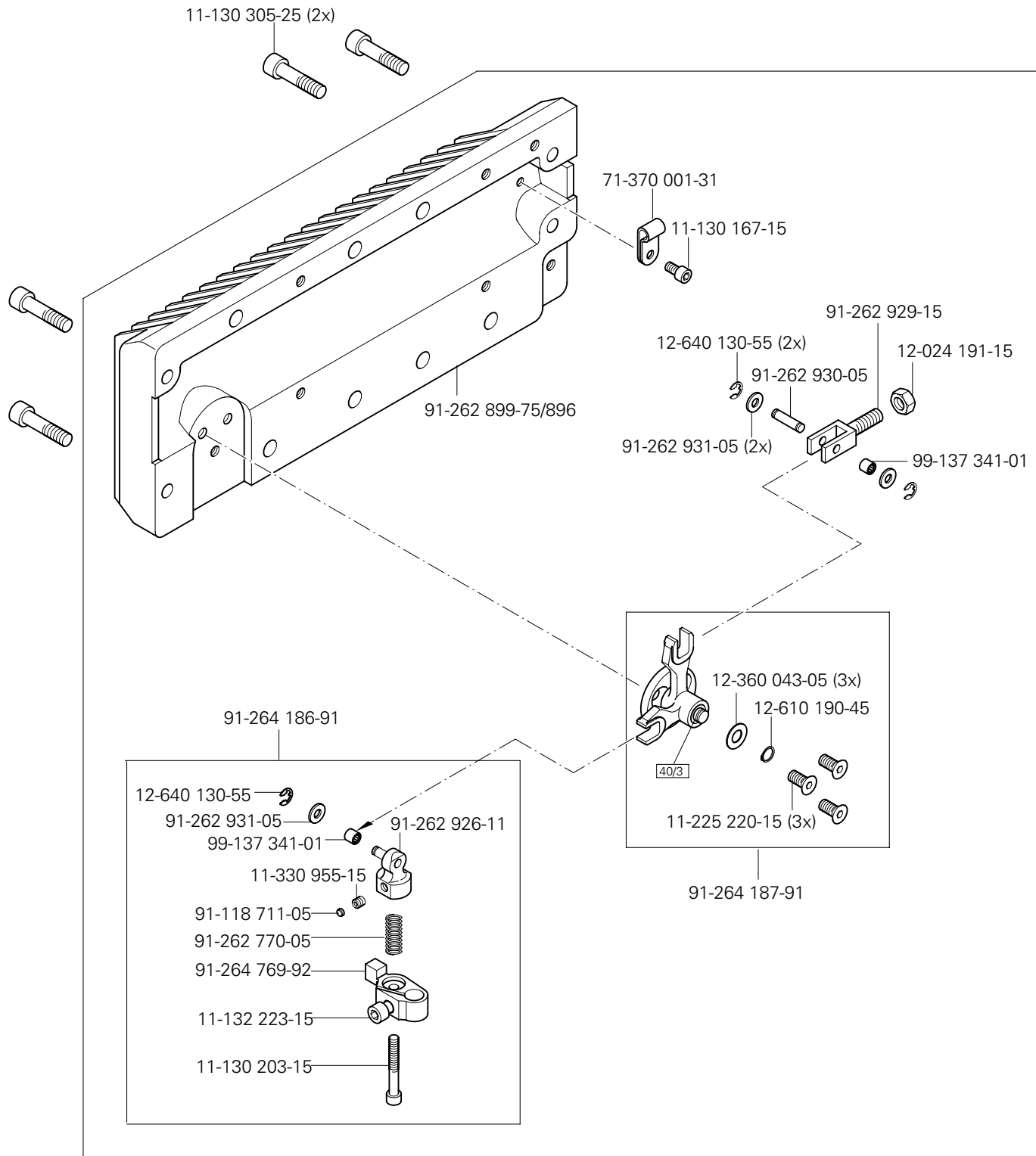
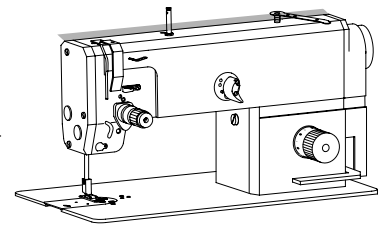

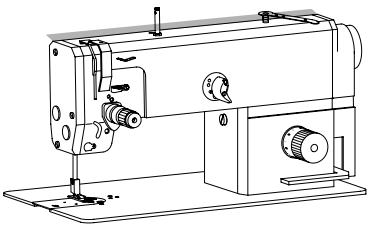

SRP
SRP
SRP
SRP

PFAFF 1181-900/24
PFAFF 1183-900/24

91-264 189-71/896

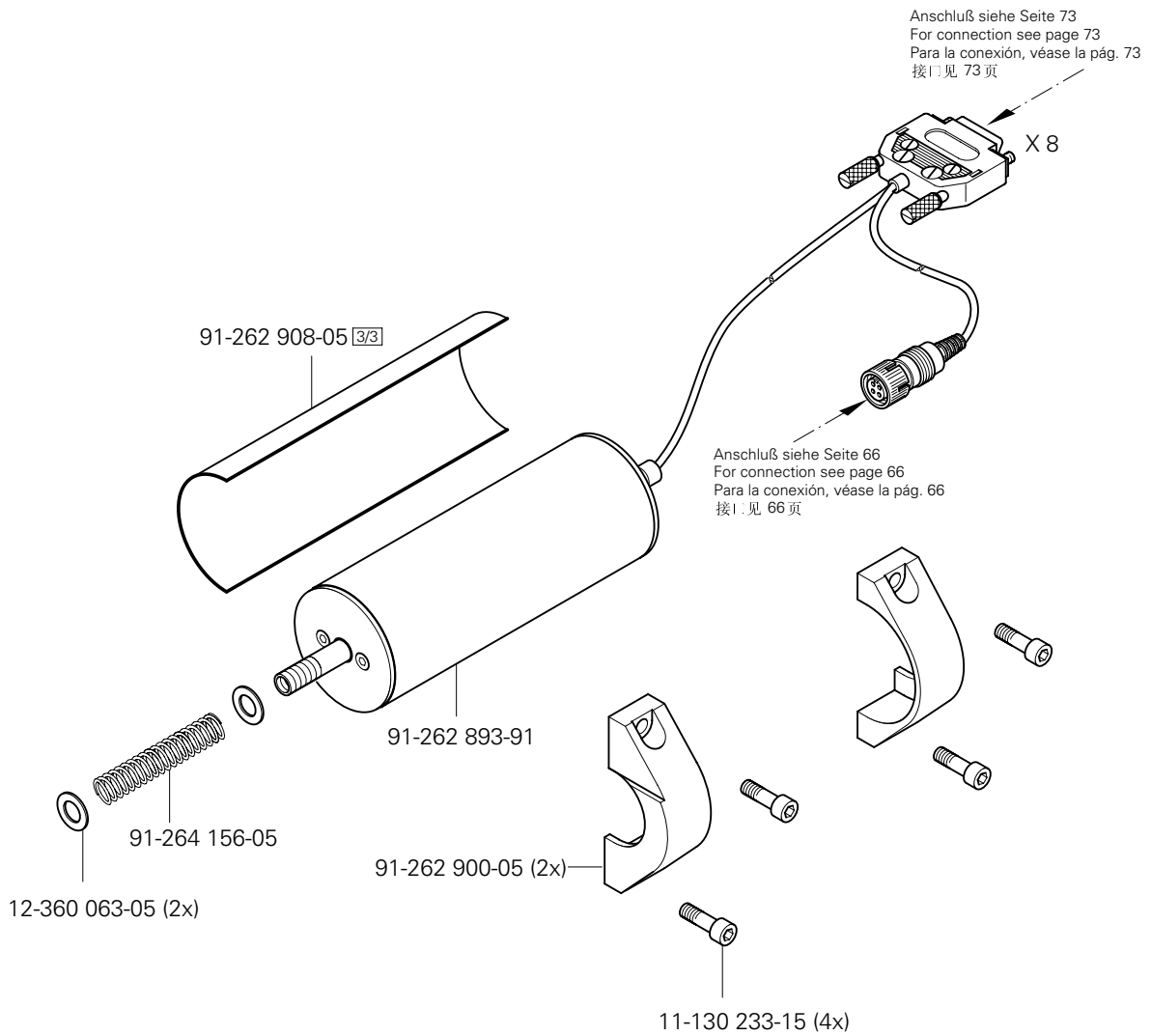

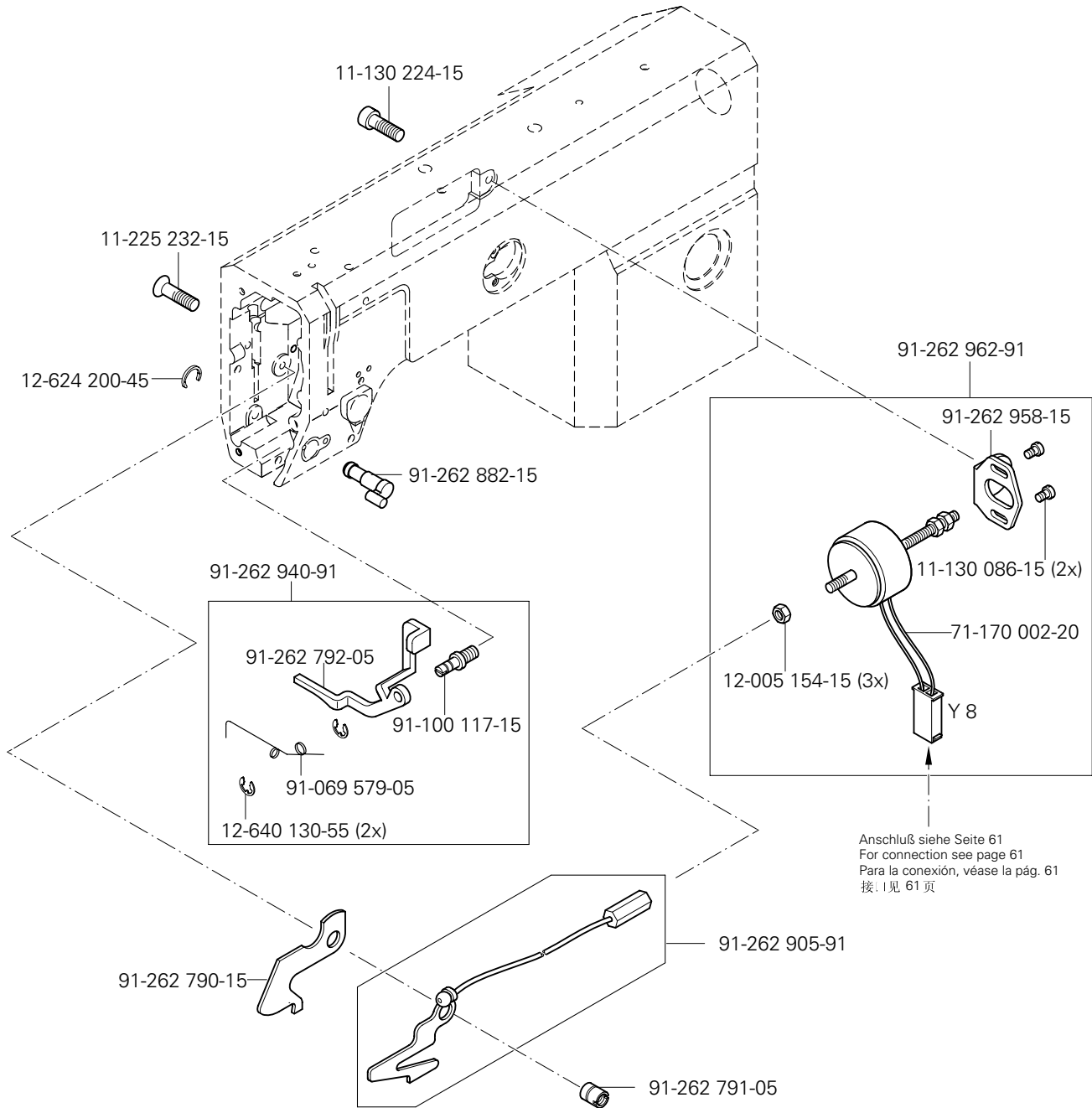
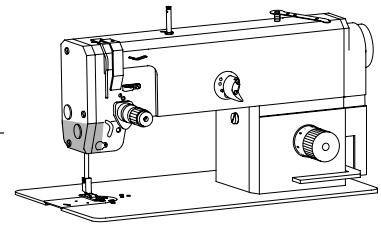

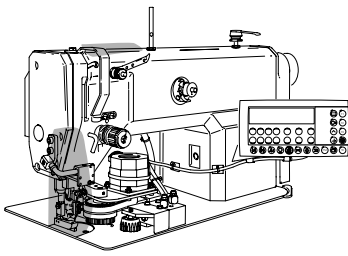

Abweichende Teile der PFAFF 3511-2/01
 Different parts for PFAFF 3511-2/01
 Piezas de la PFAFF 3511-2/01 que son diferentes
 PFAFF 3511-2/01 中有差别的零件

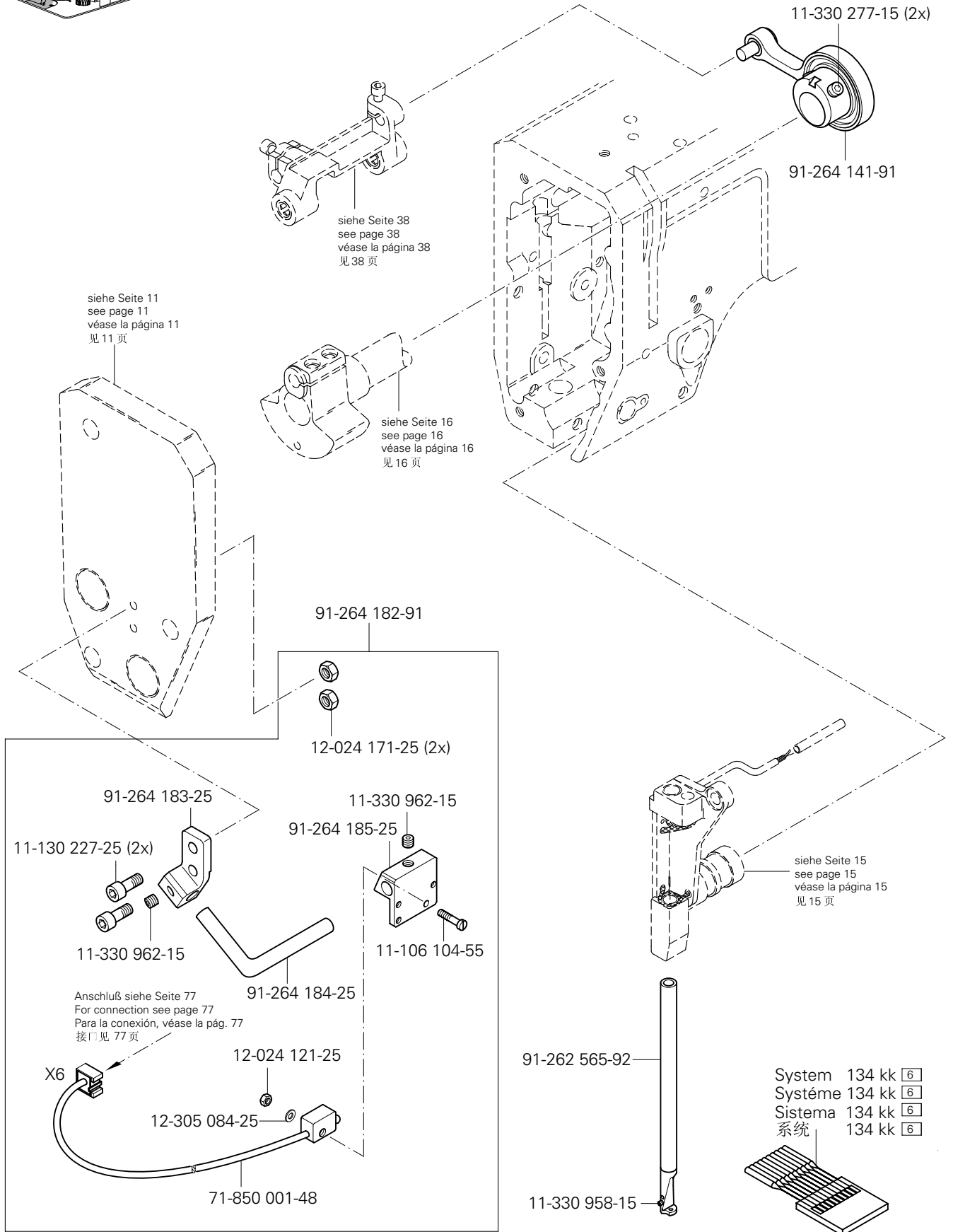

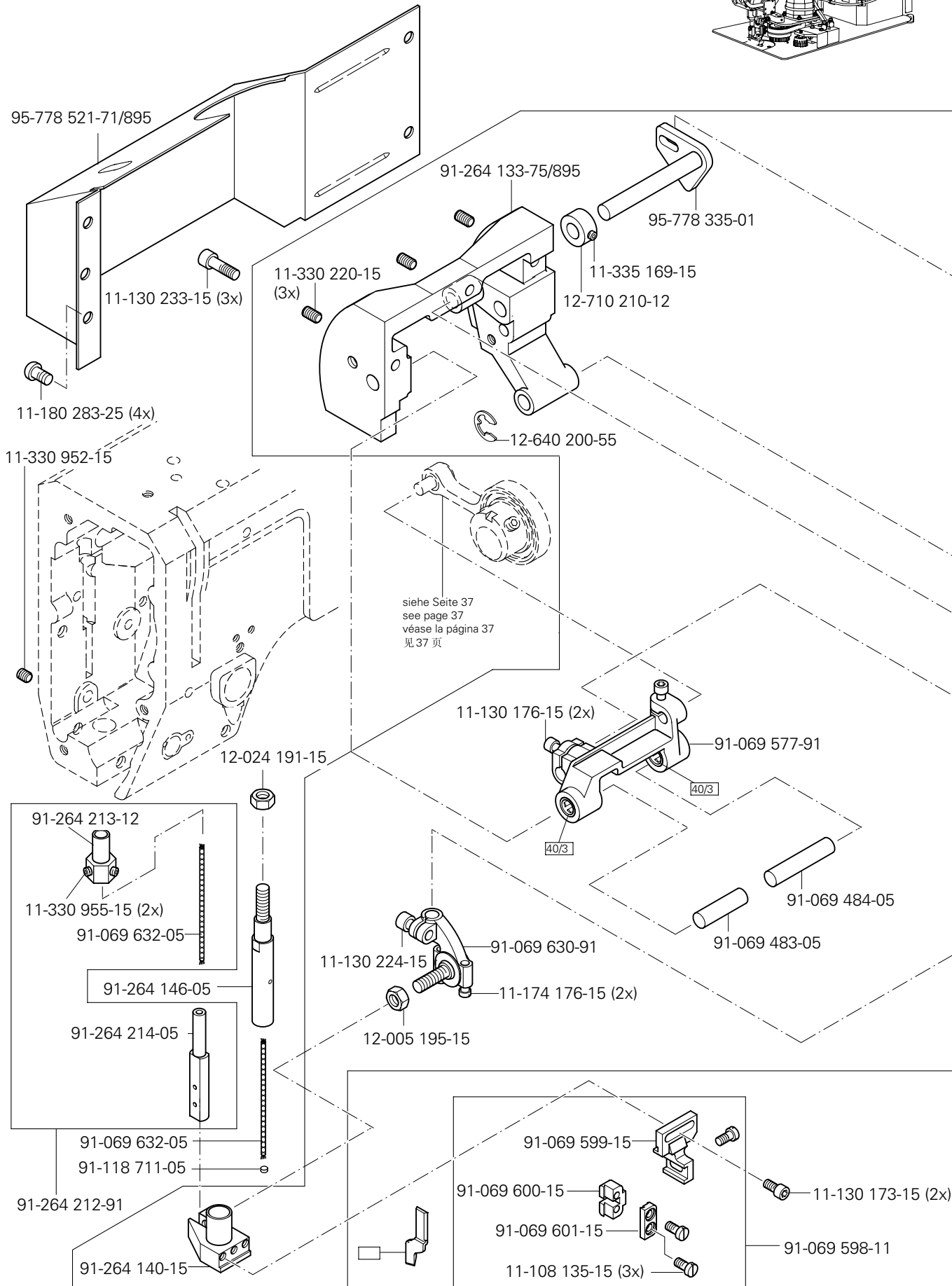
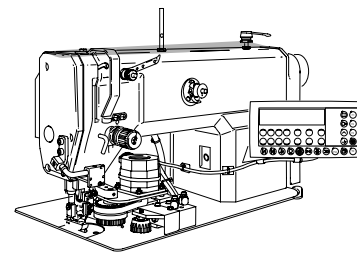

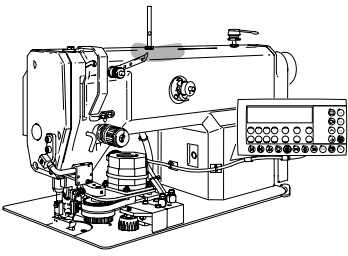

Abweichende Teile der PFAFF 3511-2/01
 Different parts for PFAFF 3511-2/01
 Piezas de la PFAFF 3511-2/01 que son diferentes
 PFAFF 3511-2/01 中有差别的零件

95-778 514-70/895

Anschluß siehe Seite 44
 For connection see page 44
 Para la conexión, véase la pág. 44
 接口见 44 页

11-130 233-15 (2x)

12-305 144-15 (2x)

11-130 239-15 (2x)

99-135 298-91 (2x)

99-137 392-91

11-330 232-15

16-041 045-21

95-778 338-75/895

12-024 171-25

11-130 239-15

11-130 227-15

12-610 200-45

91-069 489-12

91-069 486-05

91-069 789-15

91-107 265-05

11-174 176-15 (2x)

11-108 096-15

91-264 134-91

siehe Seite 38
 see page 38
 véase la página 38
 见 38 页

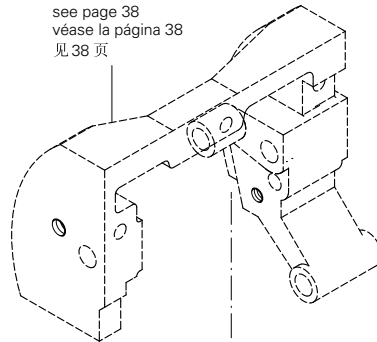

40/2

91-069 371-92

11-130 173-15 (2x)

6

Abweichende Teile der PFAFF 3511-2/01
 Different parts for PFAFF 3511-2/01
 Piezas de la PFAFF 3511-2/01 que son diferentes
 PFAFF 3511-2/01 中有差别的零件

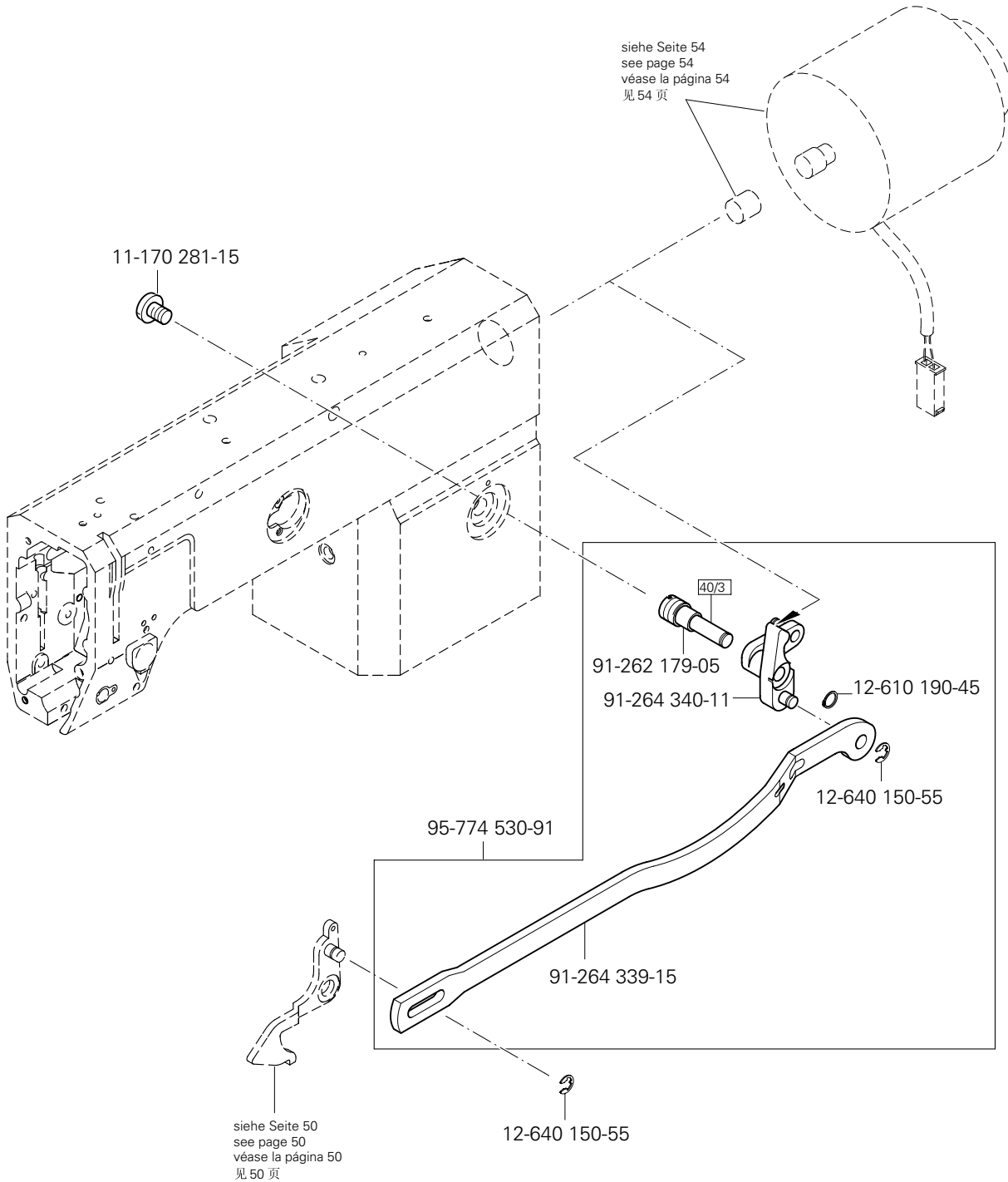
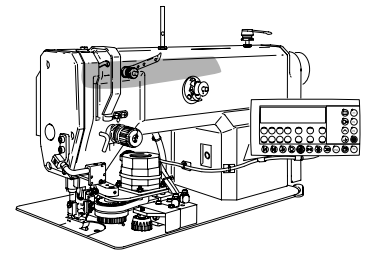

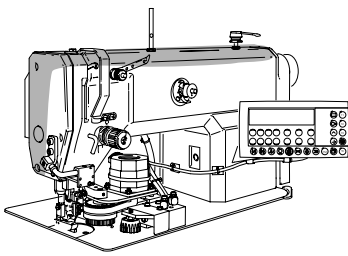

Abweichende Teile der PFAFF 3511-2/01
 Different parts for PFAFF 3511-2/01
 Piezas de la PFAFF 3511-2/01 que son diferentes
 PFAFF 3511-2/01 中有差别的零件

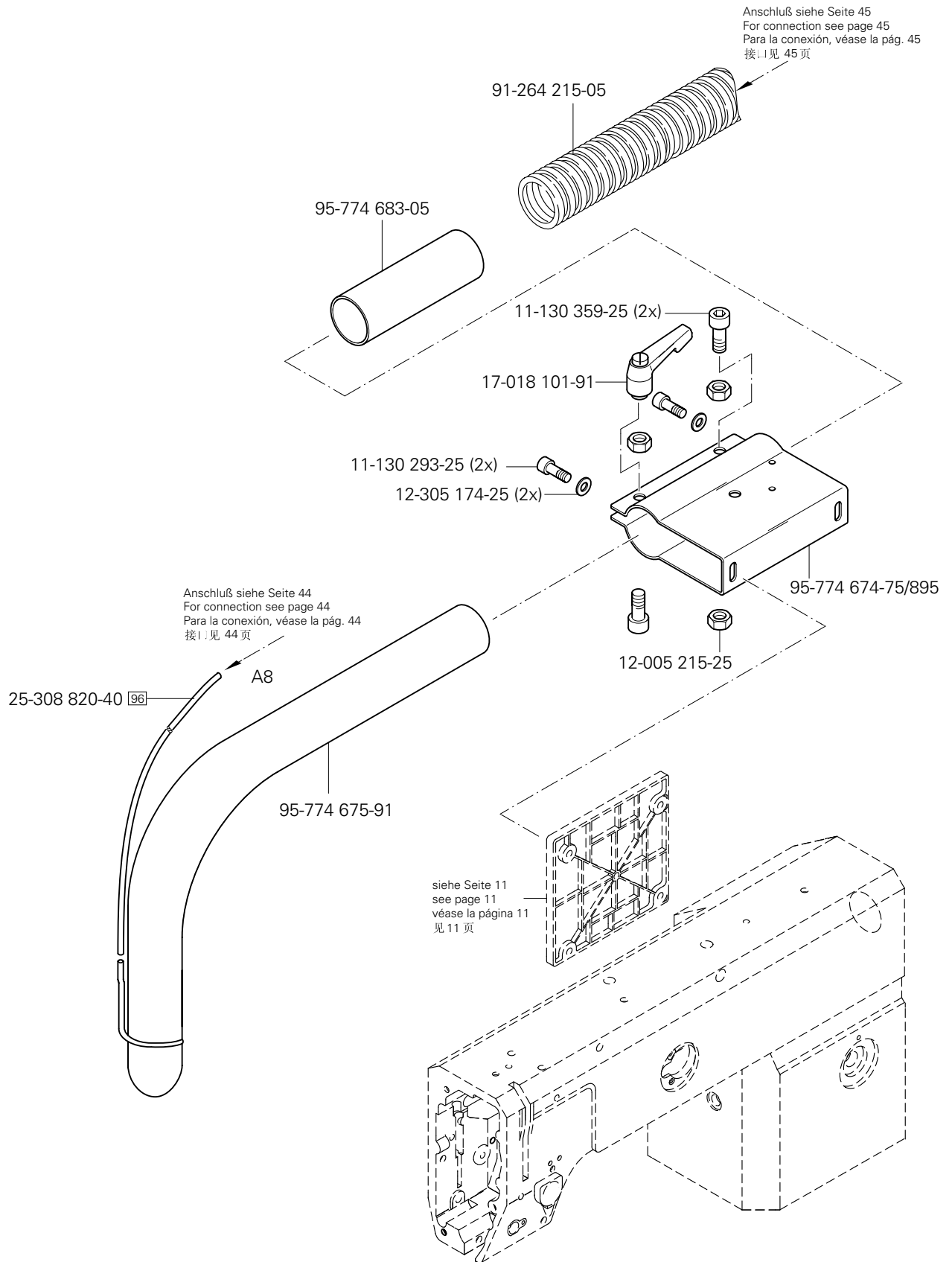

6

Abweichende Teile der PFAFF 3511-2/01 Different parts for PFAFF 3511-2/01 Piezas de la PFAFF 3511-2/01 que son diferentes PFAFF 3511-2/01 中有差别的零件

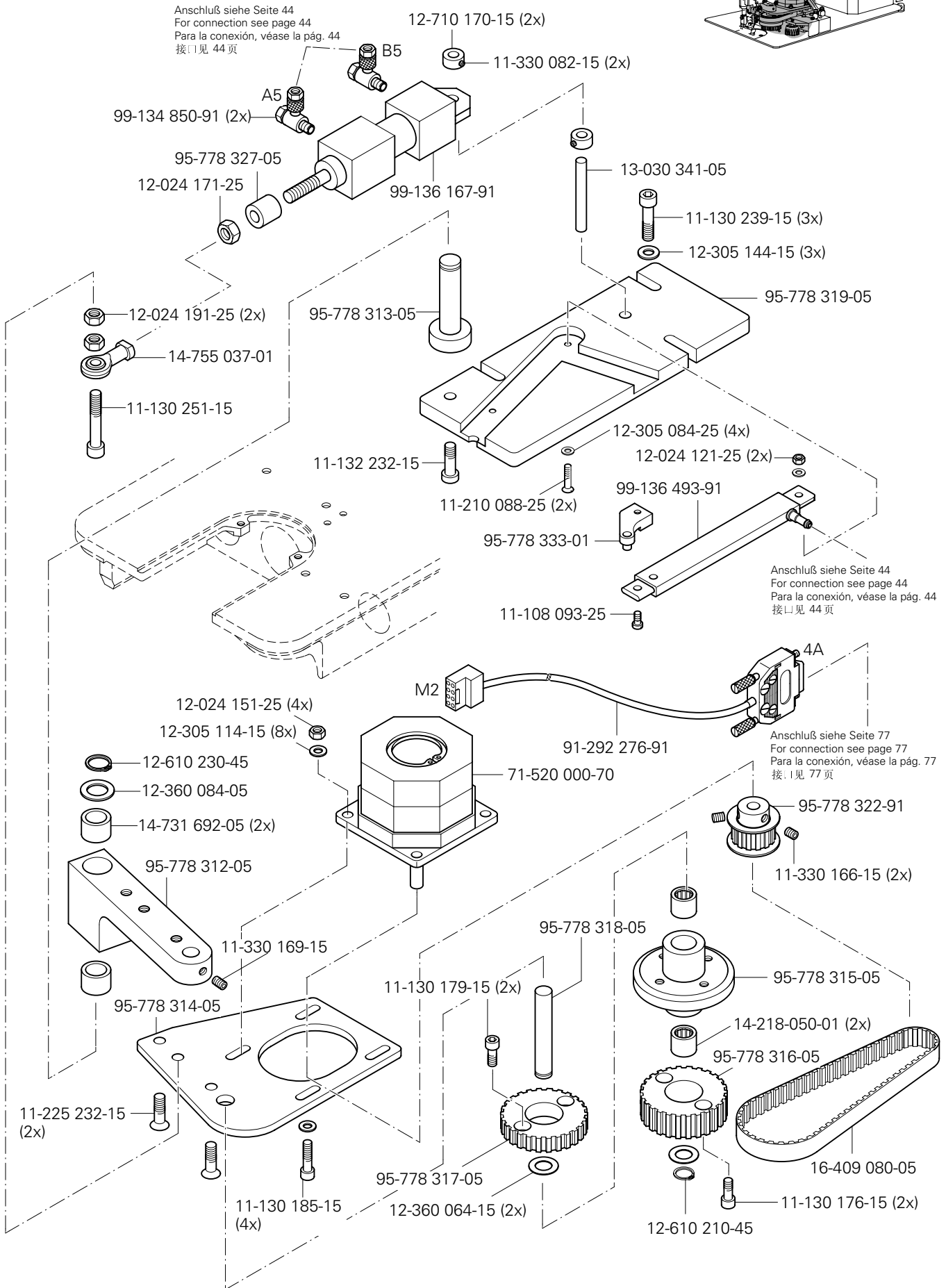
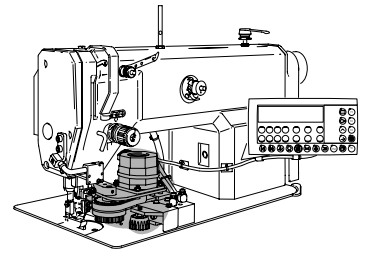

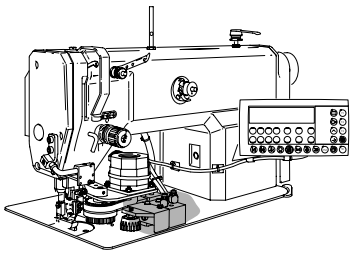

Abweichende Teile der PFAFF 3511-2/01
 Different parts for PFAFF 3511-2/01
 Piezas de la PFAFF 3511-2/01 que son diferentes
 PFAFF 3511-2/01 中有差别的零件

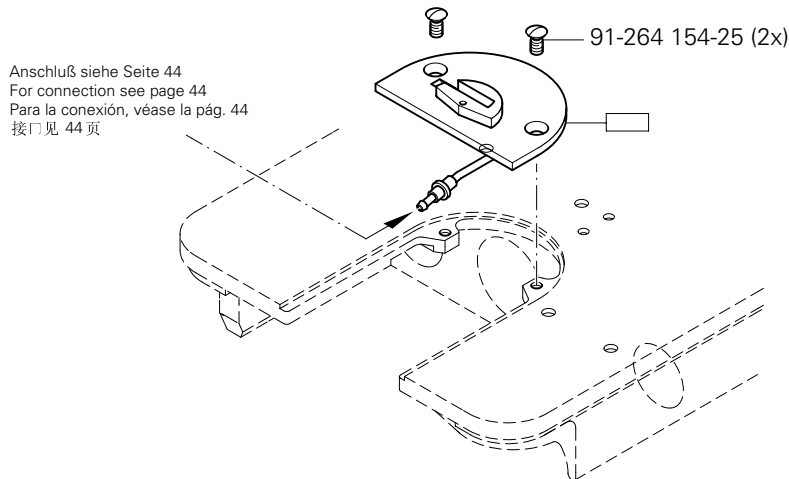
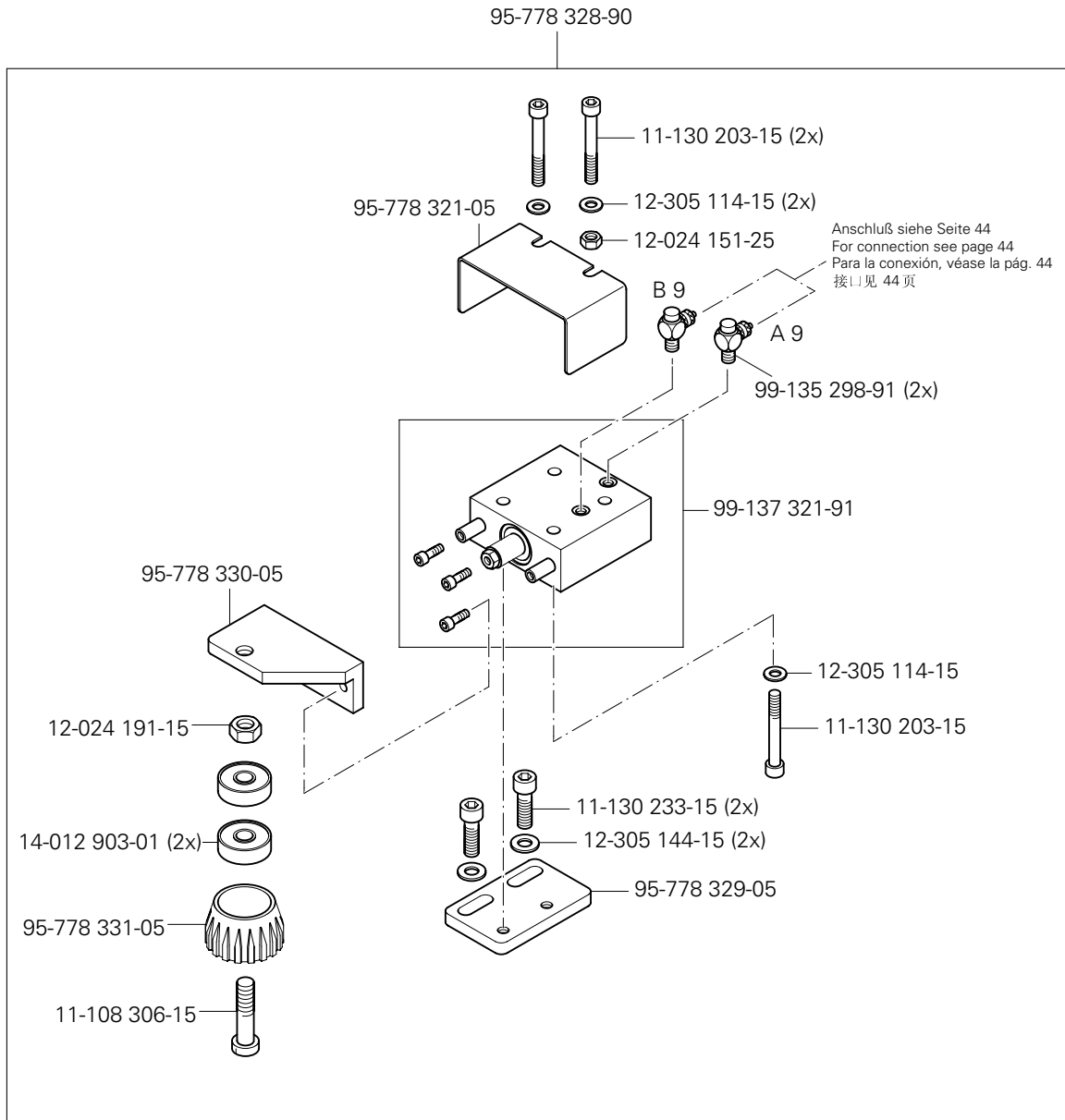

6

Abweichende Teile der PFAFF 3511-2/01 Different parts for PFAFF 3511-2/01 Piezas de la PFAFF 3511-2/01 que son diferentes PFAFF 3511-2/01 中有差别的零件

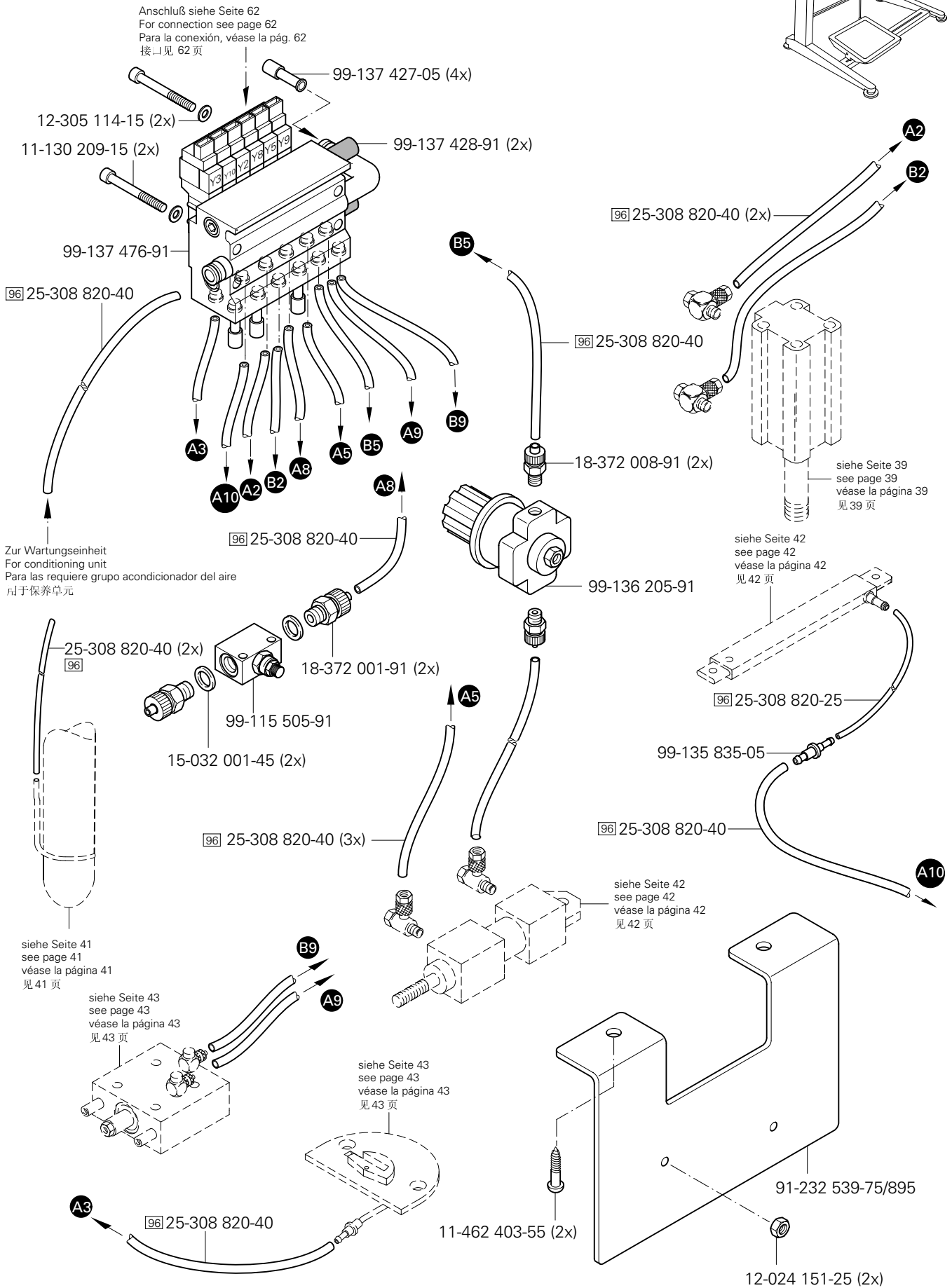
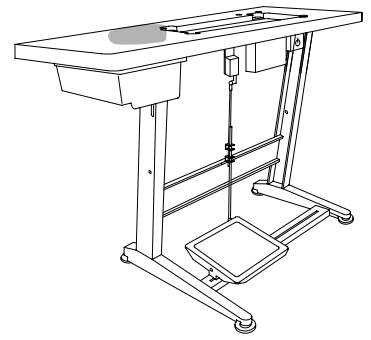

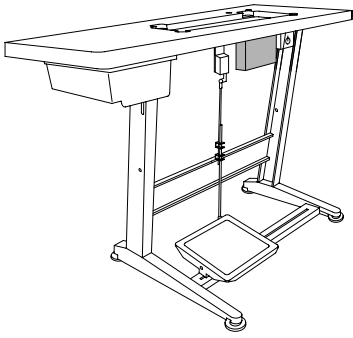

Abweichende Teile der PFAFF 3511-2/01
 Different parts for PFAFF 3511-2/01
 Piezas de la PFAFF 3511-2/01 que son diferentes
 PFAFF 3511-2/01 中有差别的零件

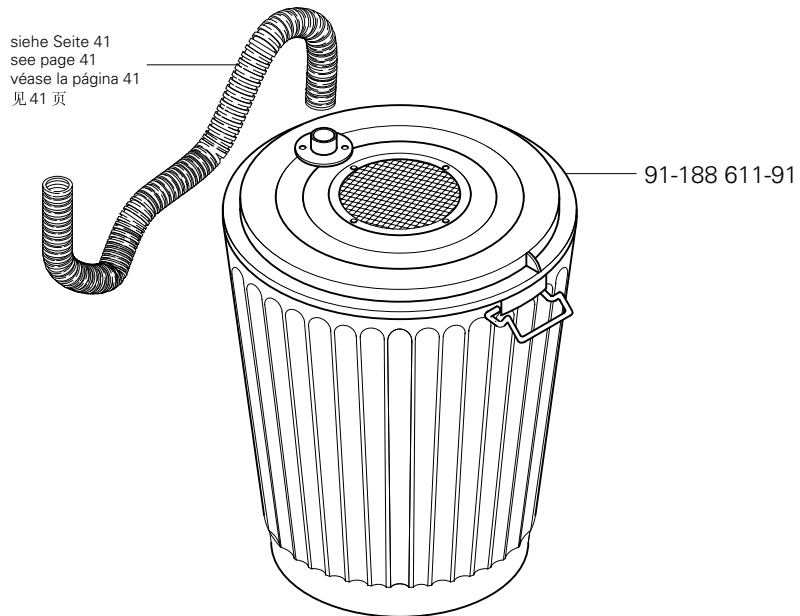
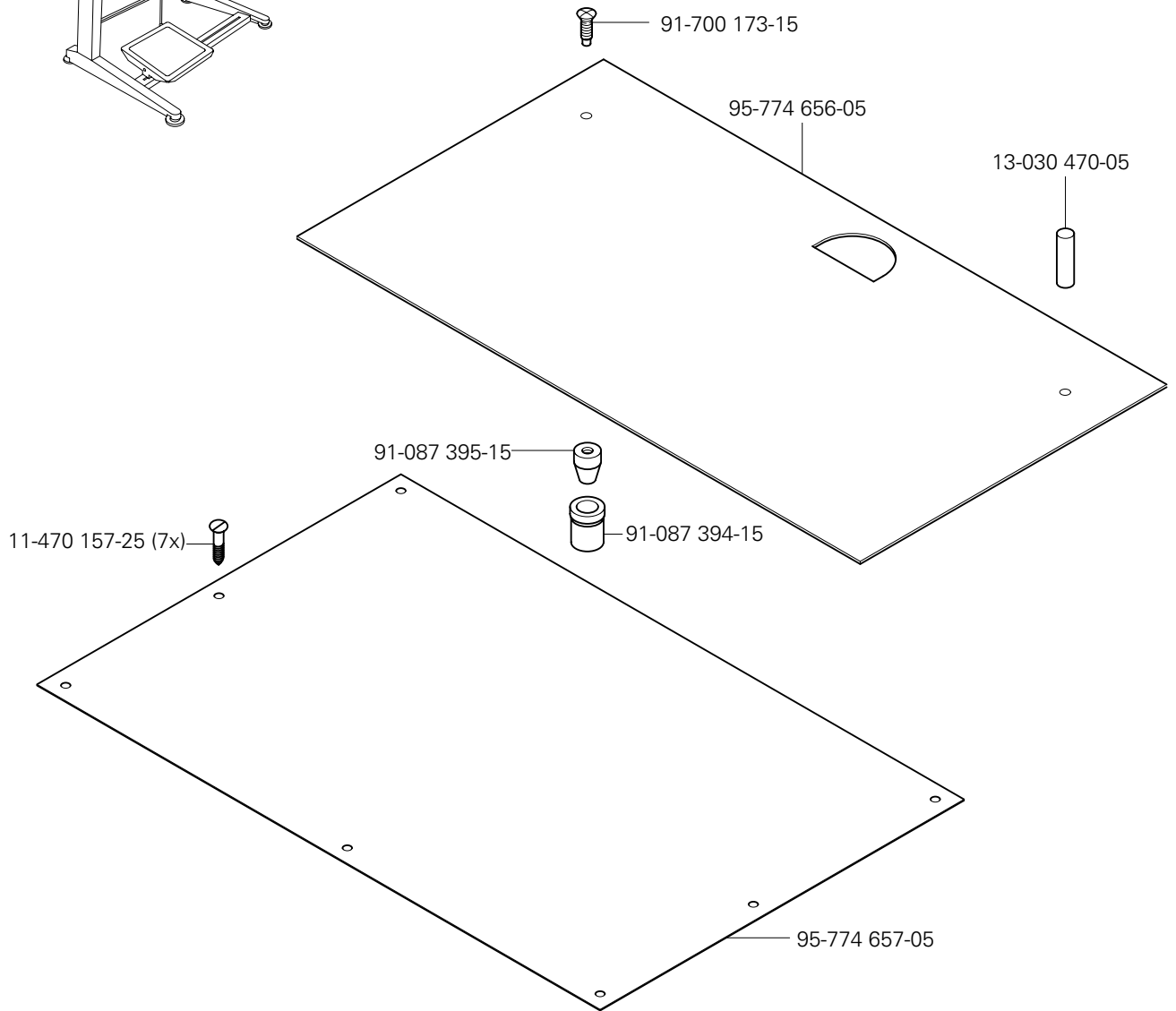

7

Abweichende Teile der PFAFF 3701-4/11
 Different parts for PFAFF 3701-4/11
 Piezas de la PFAFF 3701-4/11 que son diferentes
 PFAFF 3701-4/11 中有差别的零件

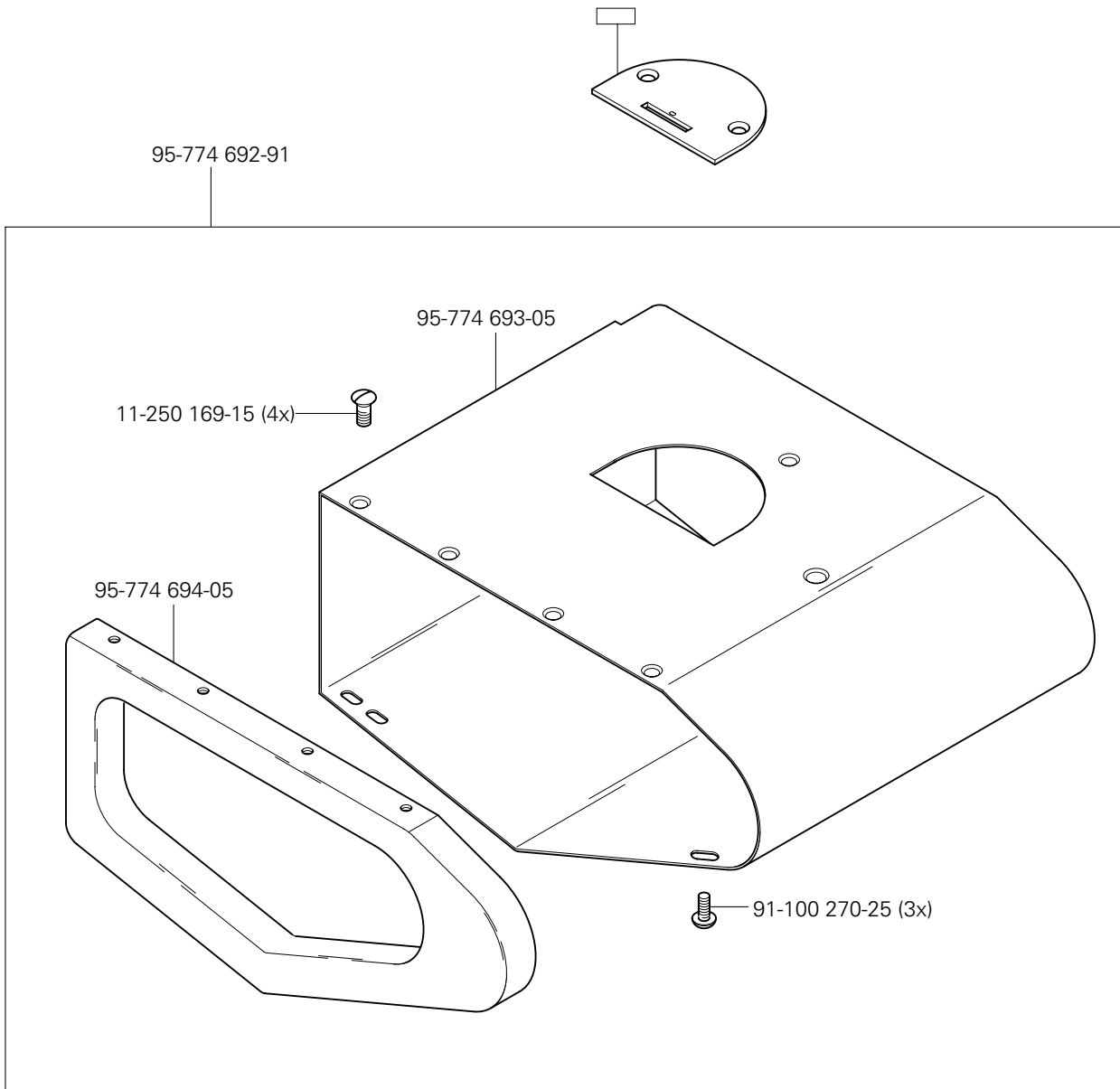
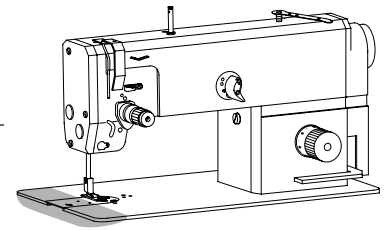

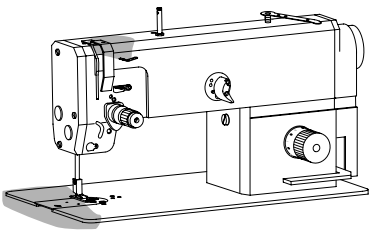

Kanten-Beschneideinrichtung (-731/01)
 Edge trimmer (-731/01)
 Recortador (-731/01)
 切边器 (-731/01)

PFAFF 1181
 PFAFF 1183

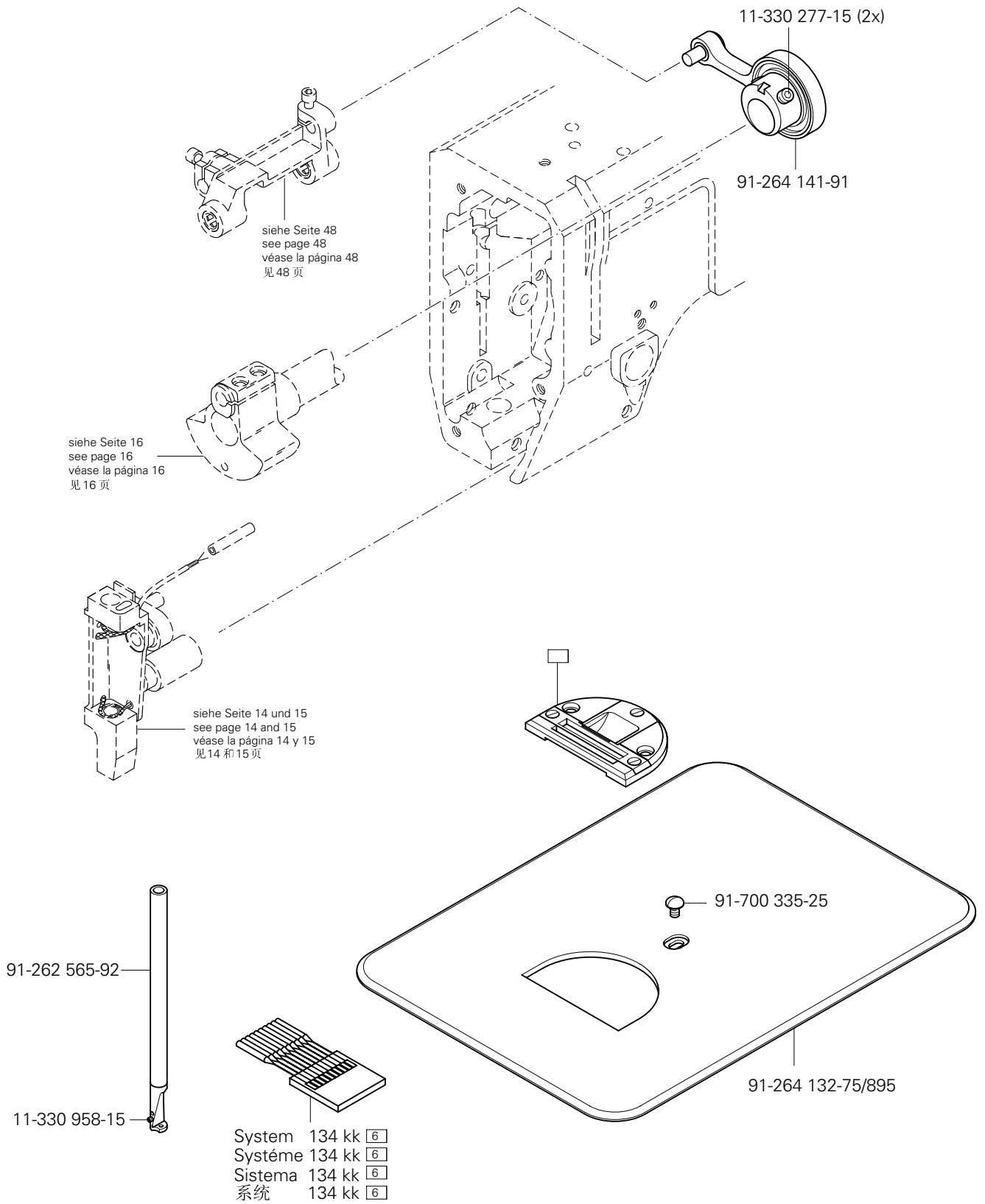

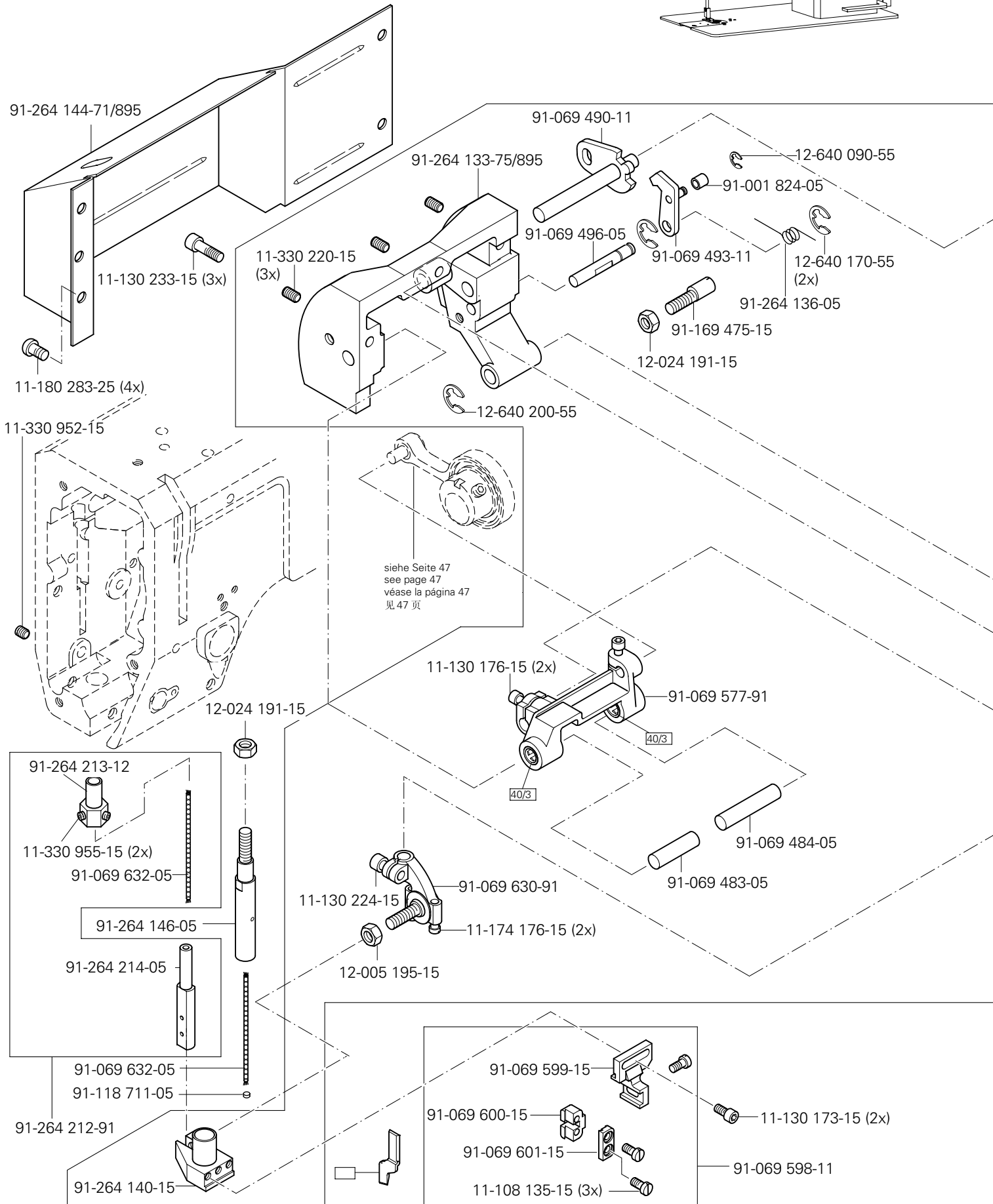
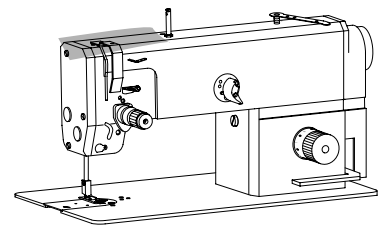

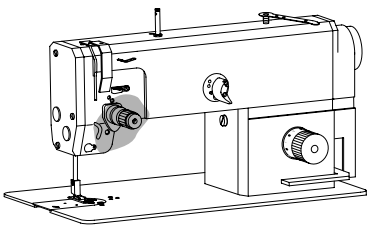

Kanten-Beschneideinrichtung (-731/01)
 Edge trimmer (-731/01)
 Recortador (-731/01)
 切边器 (-731/01)

PFAFF 1181
 PFAFF 1183

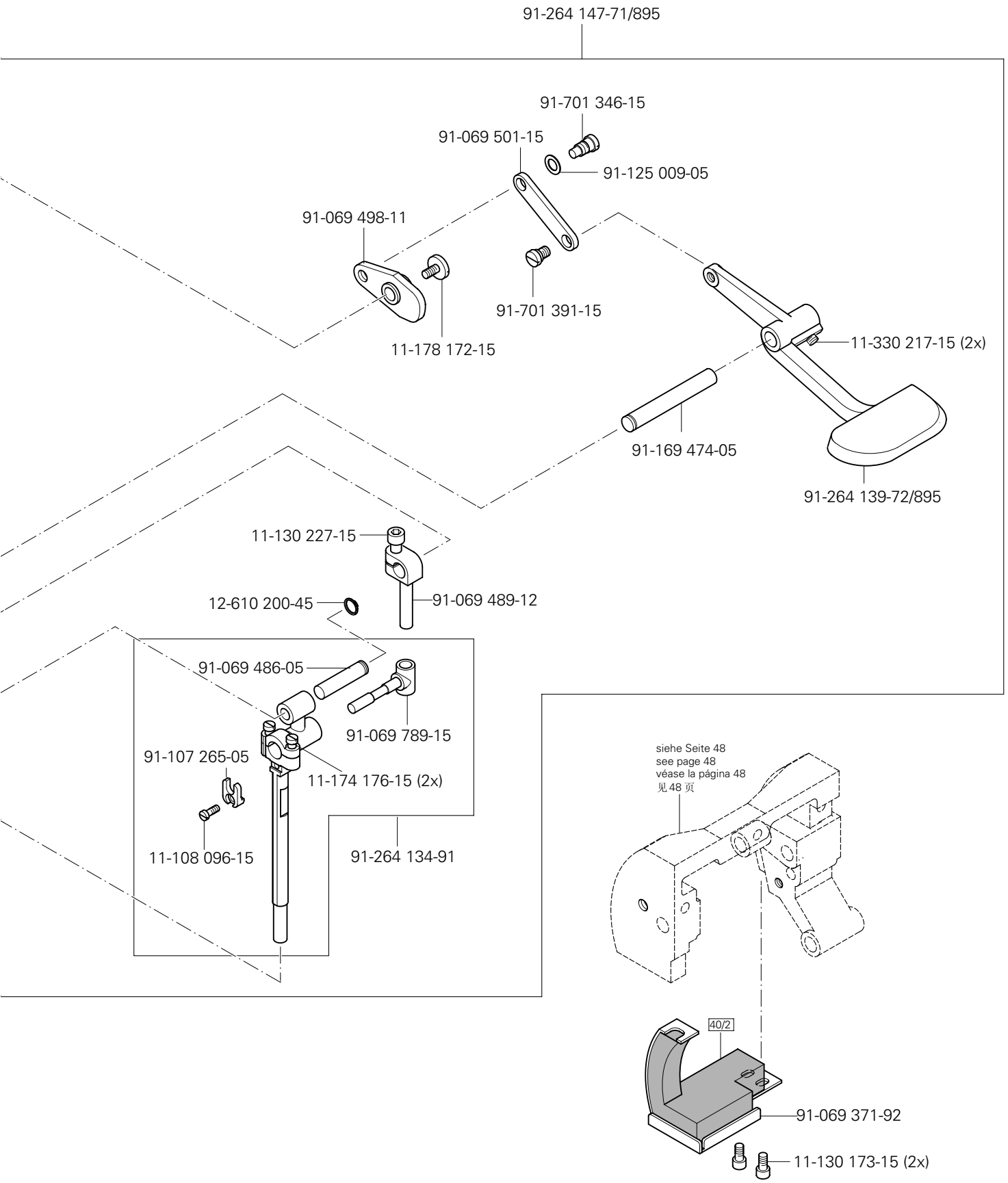

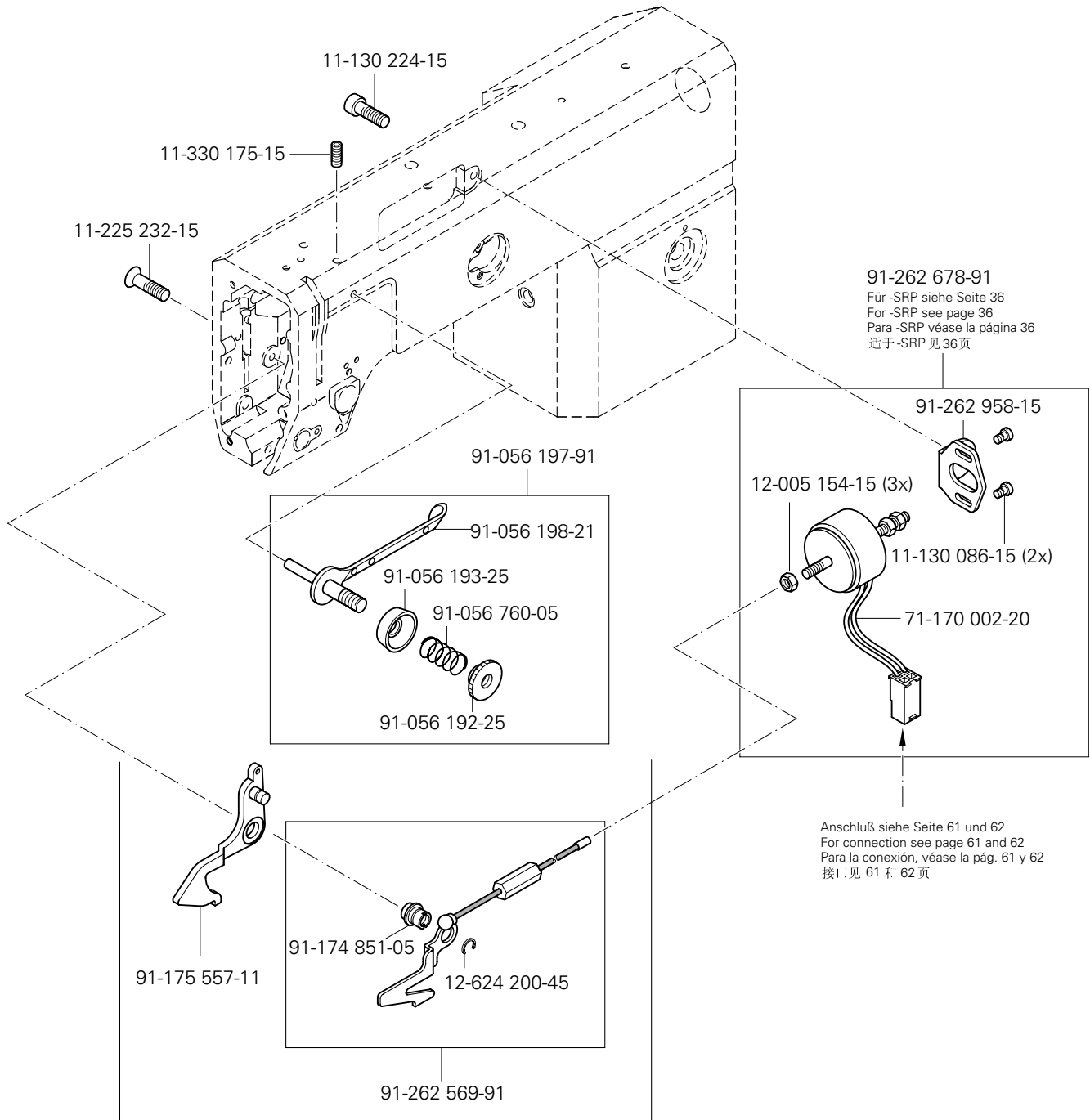
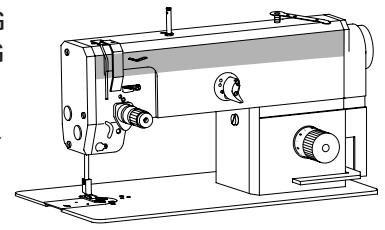

91-262 678-91
 Für -SRP siehe Seite 36
 For -SRP see page 36
 Para -SRP véase la página 36
 适于-SRP 见36页

Anschluß siehe Seite 61 und 62
 For connection see page 61 and 62
 Para la conexión, véase la pág. 61 y 62
 接1. 见 61 和 62 页

Für -SRP siehe Seite 36
 For -SRP see page 36
 Para -SRP véase la página 36
 适于-SRP 见36页

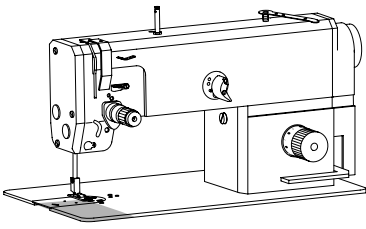

Fadenabschneid-Einrichtung (-900/24)
 Thread trimmer (-900/24)
 Cortahilos (-900/24)
 切线器 (-900/24)

PFAFF 1181;1181-D;1181-G
 PFAFF 1183;1183-D;1183-G
 PFAFF 3511
 PFAFF 3701

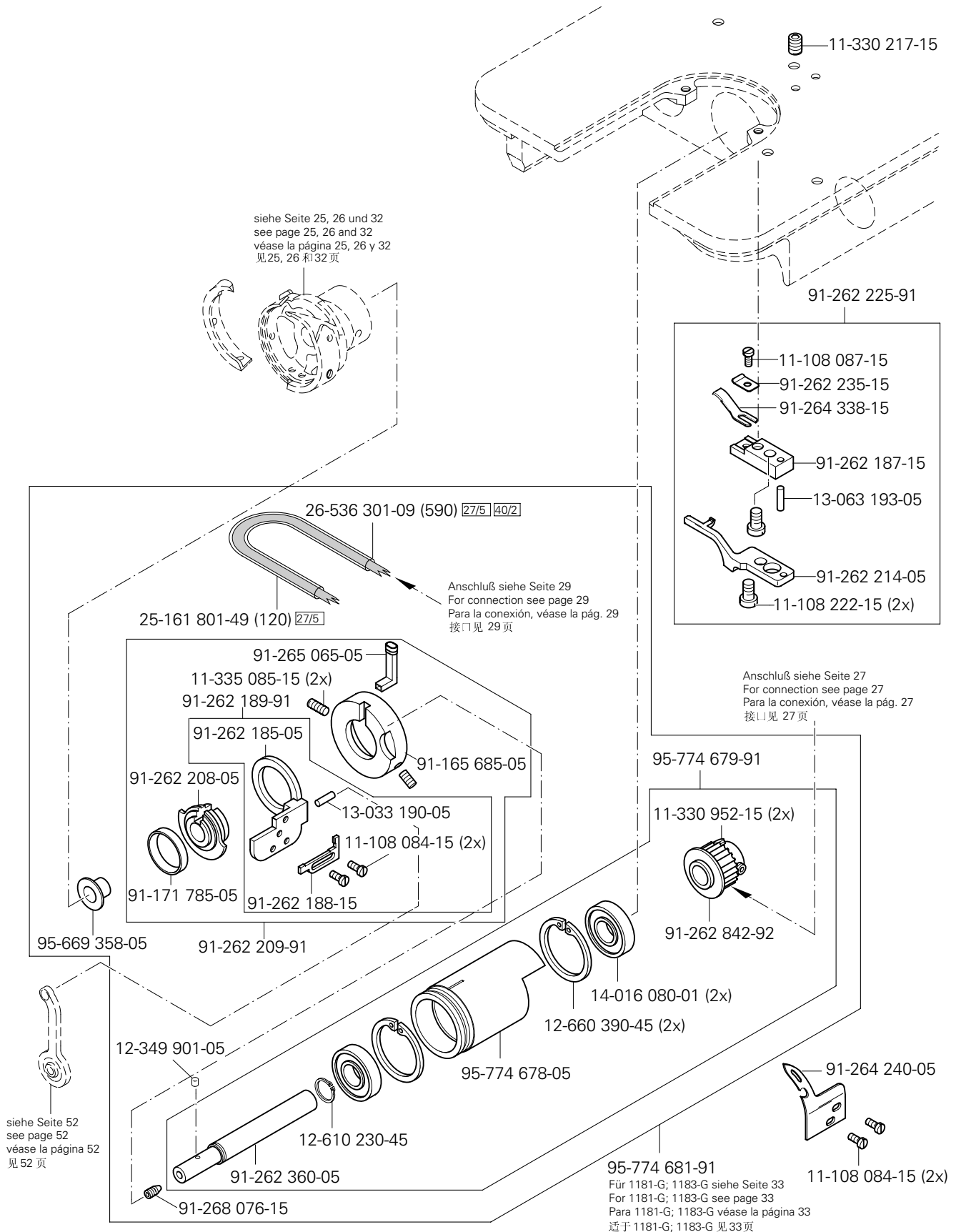

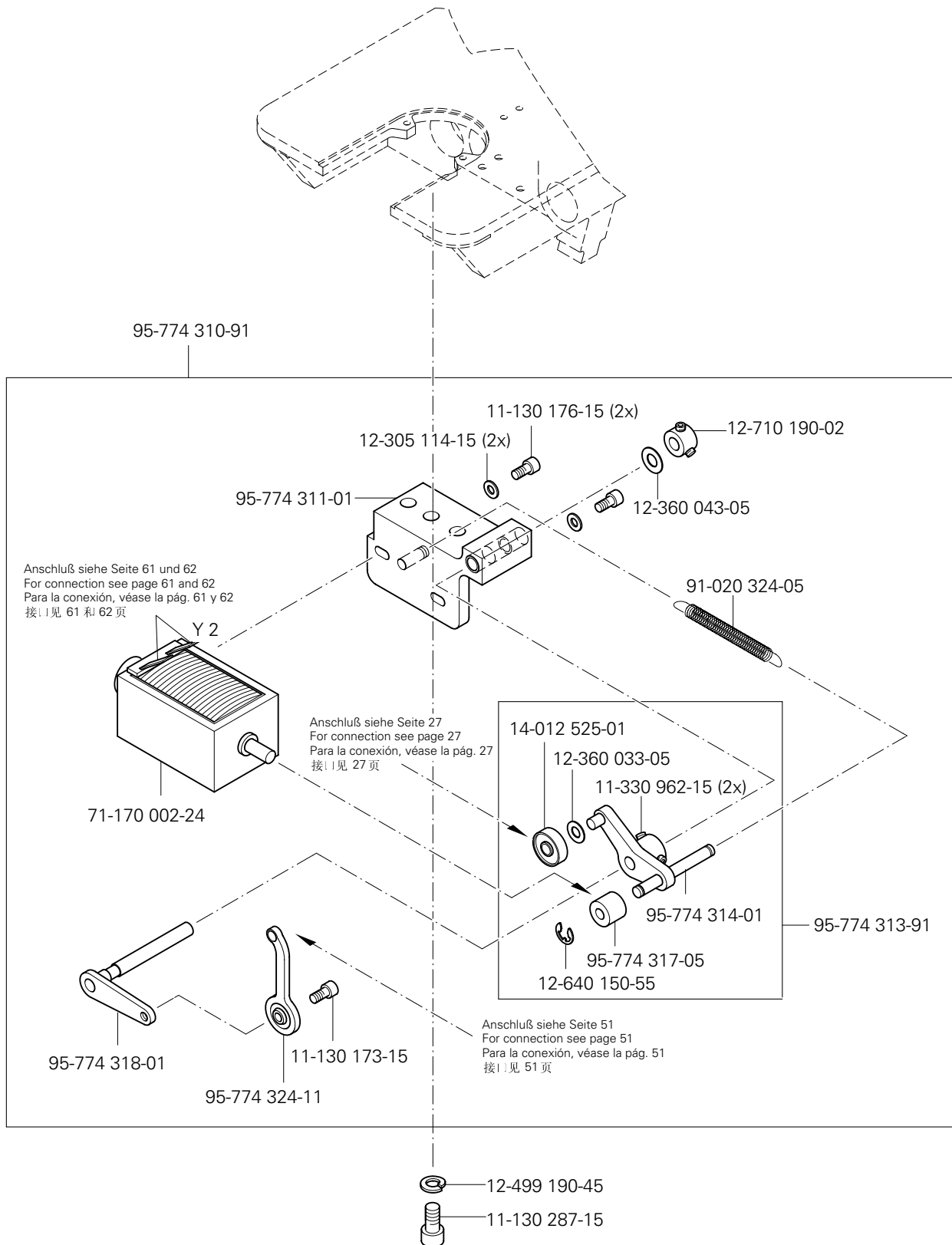
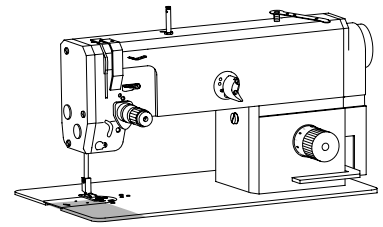

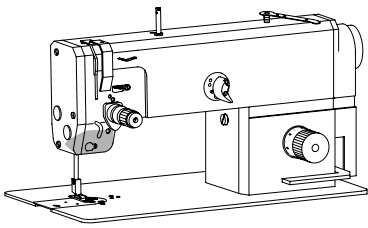

Fadenklemme (-909/14)
 Thread trapper (-909/14)
 Pinza sujetahilos (-909/14)
 夹线器 (-909/14)

PFAFF 1181;1181-D;1181-G
 PFAFF 1183;1183-D;1183-G
 PFAFF 1181-SRP;1183-SRP
 PFAFF 3701

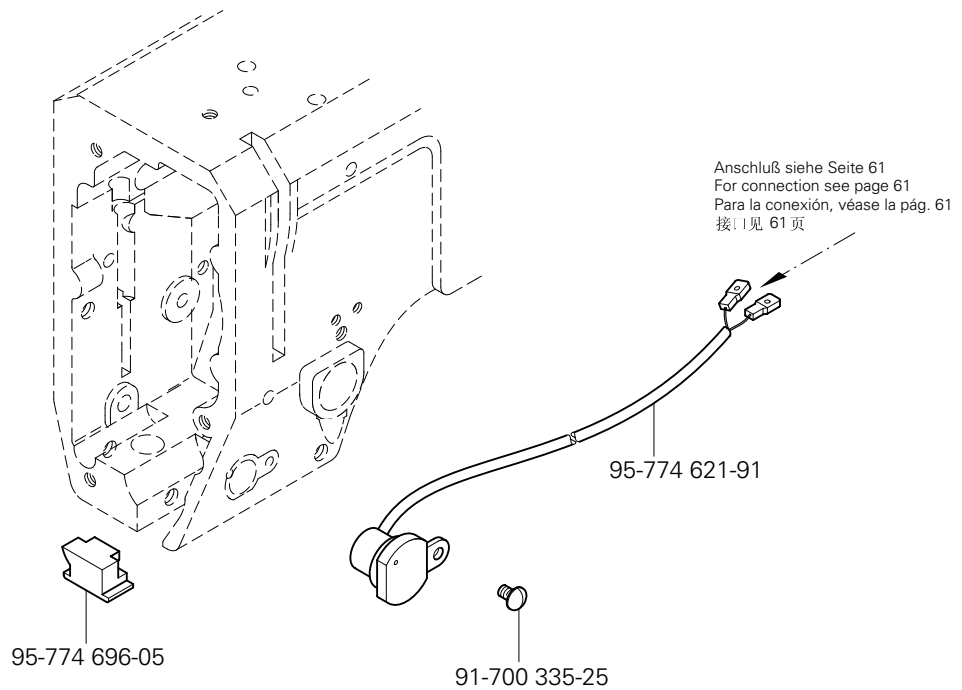

11

Presserfuß-Automatik (-910/06)

Automatic presser lifter (-910/06)

Alzaprensatelas (-910/06)

压脚自动提升器 (-910/06)

PFAFF 1181-900/24;1181- D-900/24;1181-G-900/24

PFAFF 1183-900/24;1183- D-900/24;1183-G-900/24

PFAFF 1181-731/01-900/24;1183-731/01-900/24

PFAFF 3511

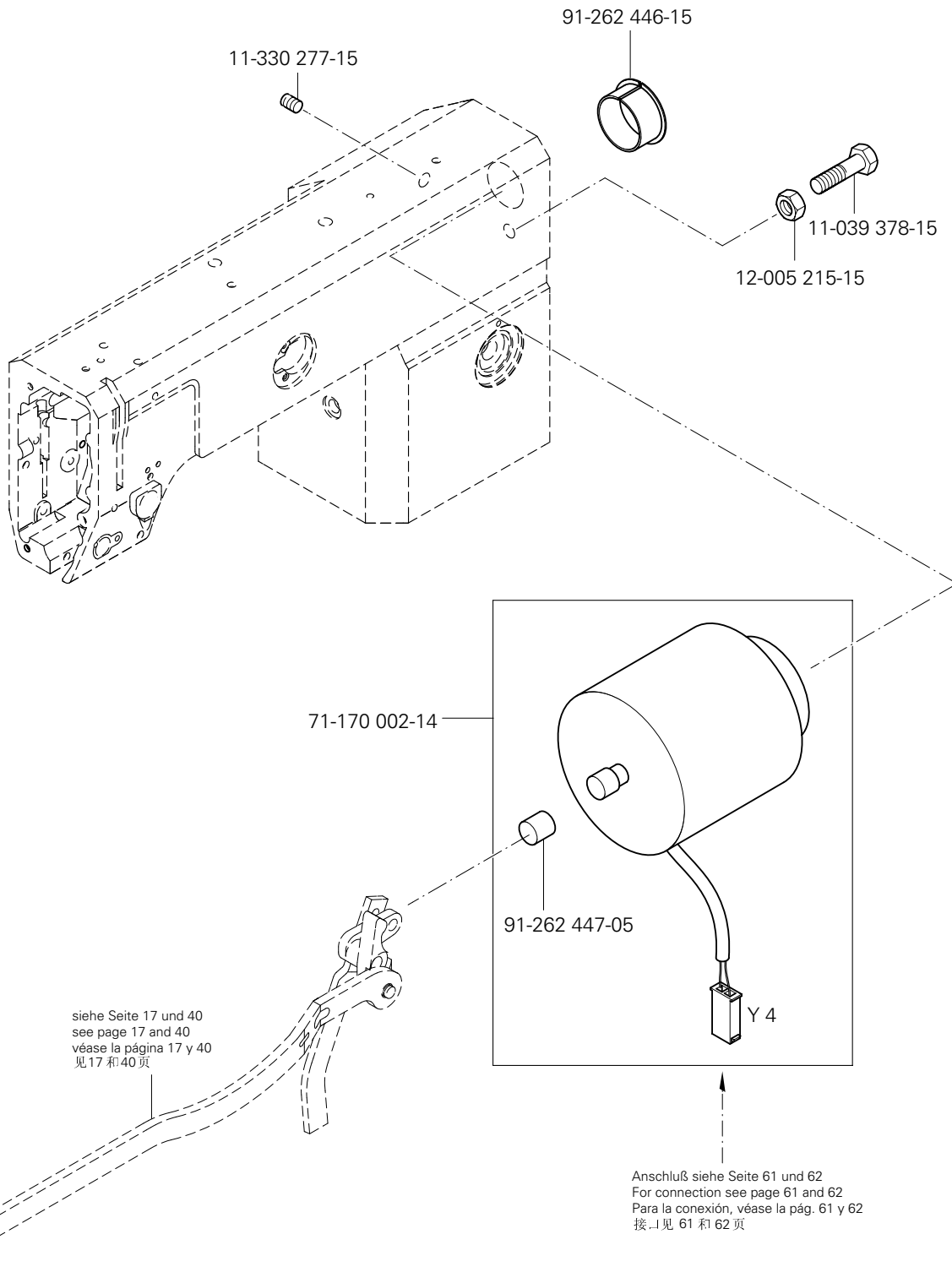
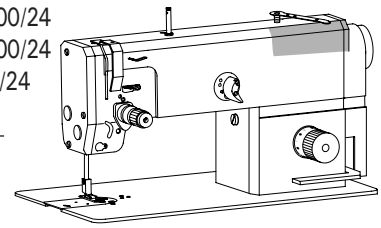

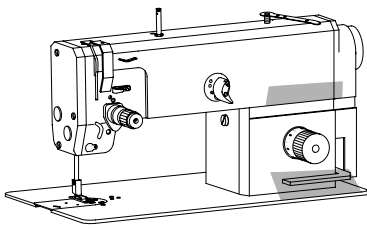

Verriegelungs-Einrichtung (-911/37) PFAFF 1181-900/24;1181-D-900/24;1181-G-900/24
 Backtacking mechanism (-911/37) PFAFF 1183-900/24;1183-D-900/24;1183-G-900/24
 Rematador (-911/37) PFAFF 1181-731/01-900/24;1183-731/01-900/24
 锁紧装置 (-911/37) PFAFF 3701

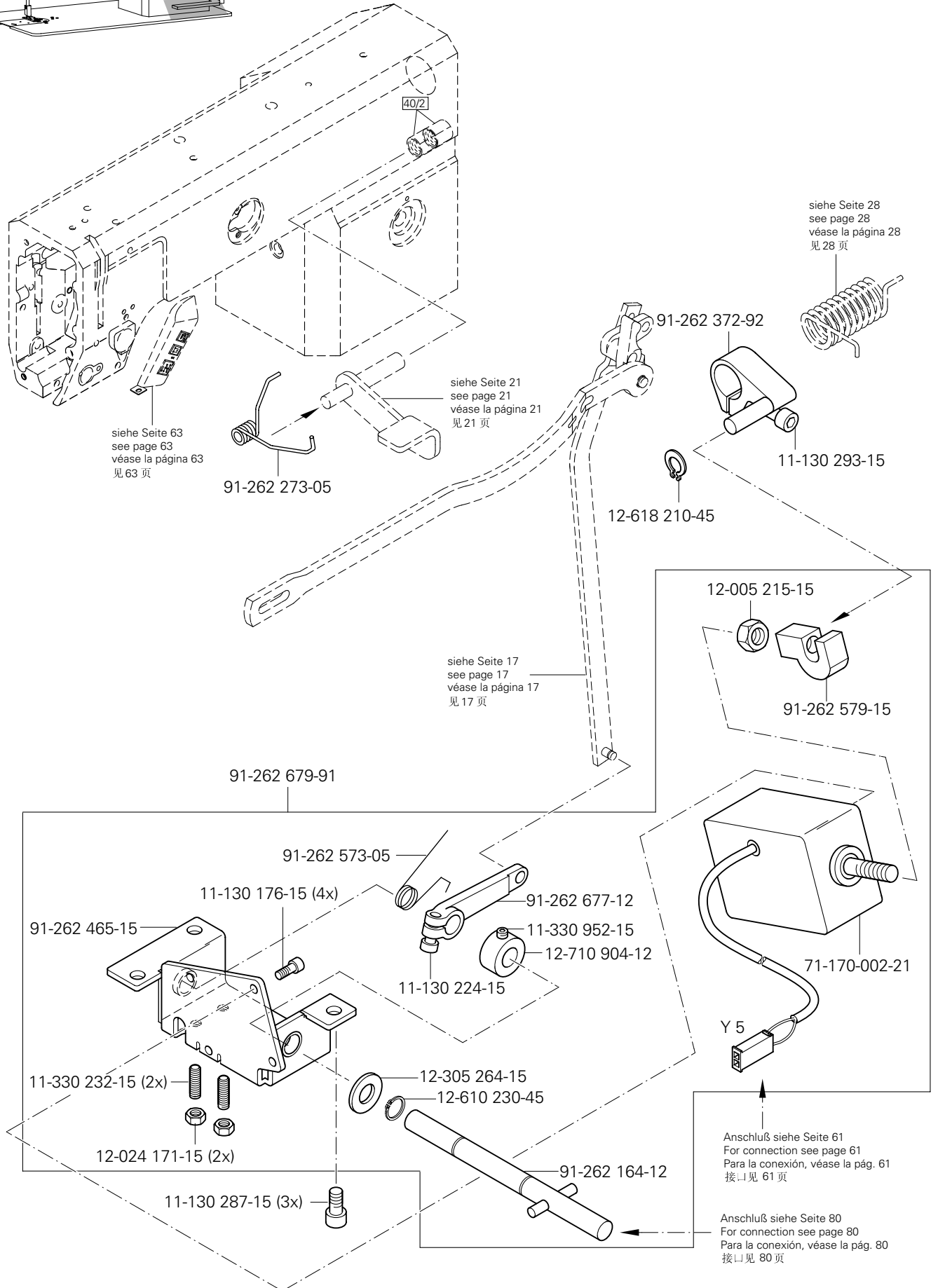

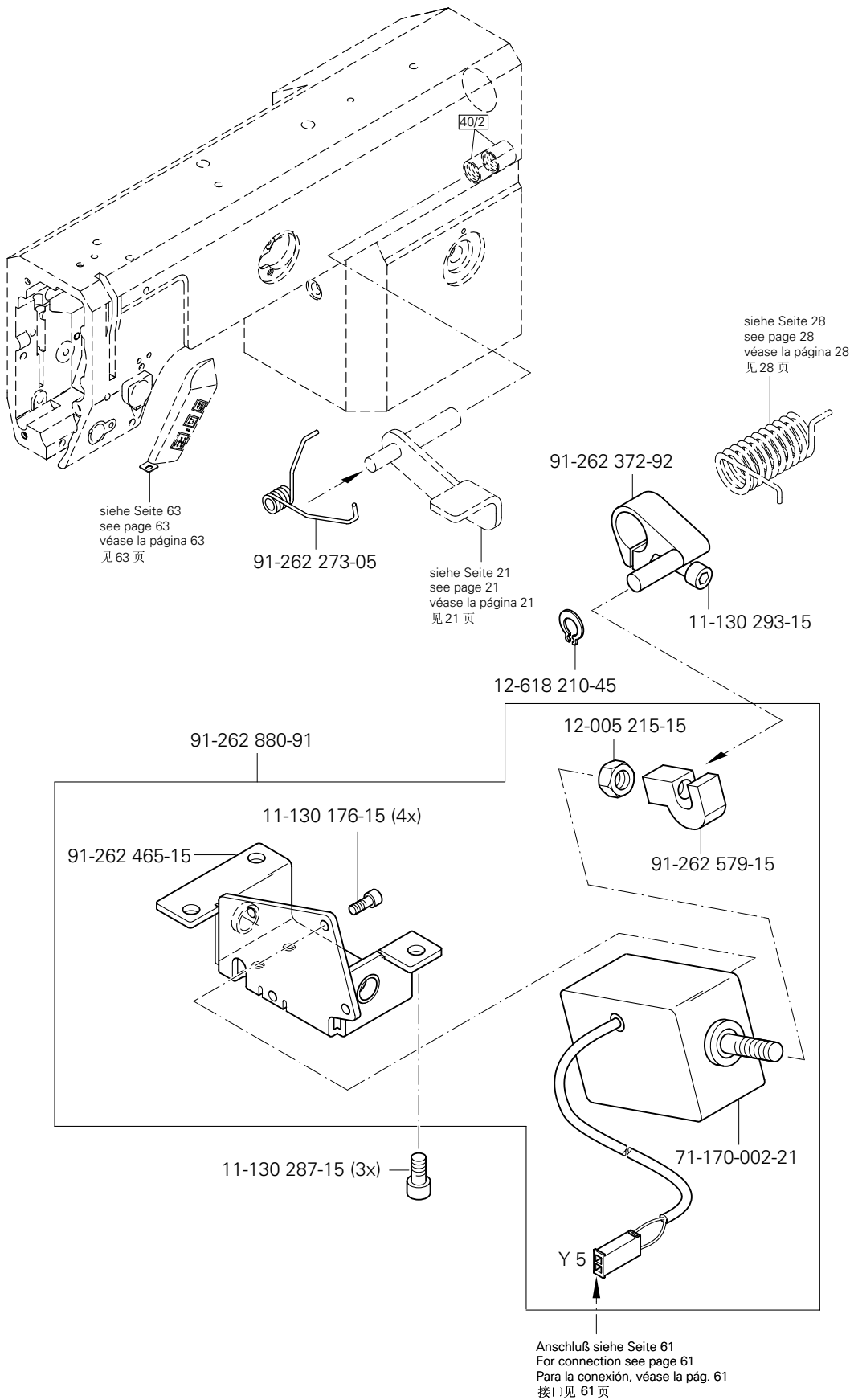
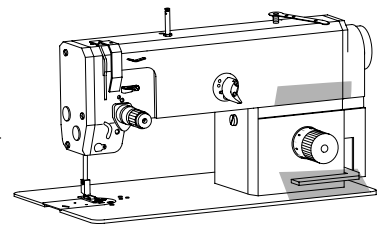

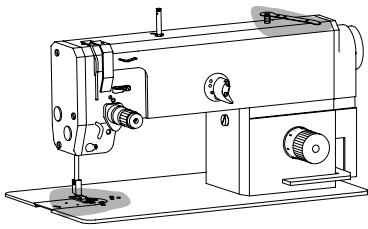

Spulenfadenvorratswächter (-926/06) PFAFF 1181; 1183
 Bobbin thread supply monitor (-926/06) PFAFF 1181-SRP; 1183-SRP
 Detector del hilo de la canilla (-926/06) PFAFF 1181-731/01; 1183-731/01
 底线余量监视器 (-926/06) PFAFF 1181-948/26; 1183-948/26

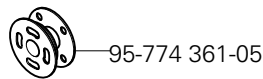
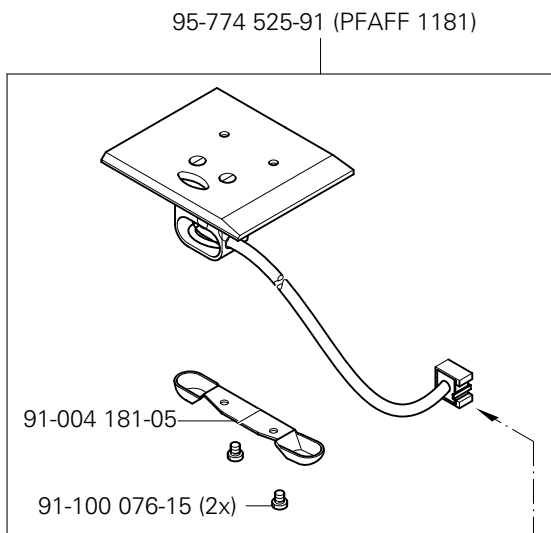
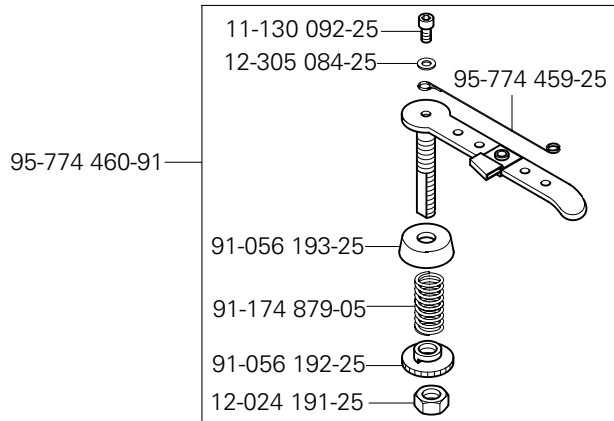

Anschluß siehe Seite 71, 73 und 75
 For connection see page 71, 73 and 75
 Para la conexión, véase la pág. 71, 73 y 75
 接口见 71, 73 和 75 页

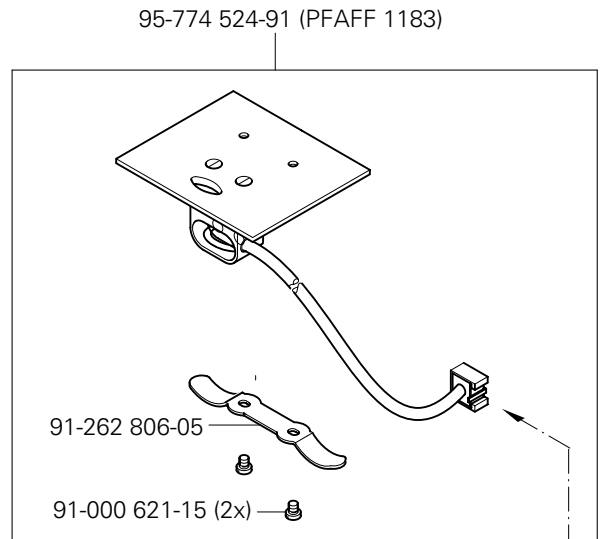

Anschluß siehe Seite 71, 73 und 75
 For connection see page 71, 73 and 75
 Para la conexión, véase la pág. 71, 73 y 75
 接口见 71, 73 和 75 页

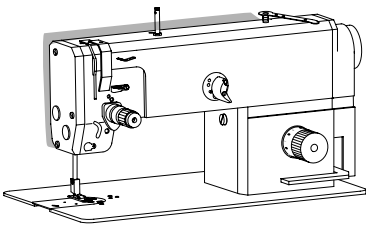

Walzentransport-Einrichtung (-948/26)

Puller feed (-948/26)

Puller (-948/26)

滚筒送料器 (-948/26)

PFAFF 1181-900/24

PFAFF 1183-900/24

PFAFF 3701

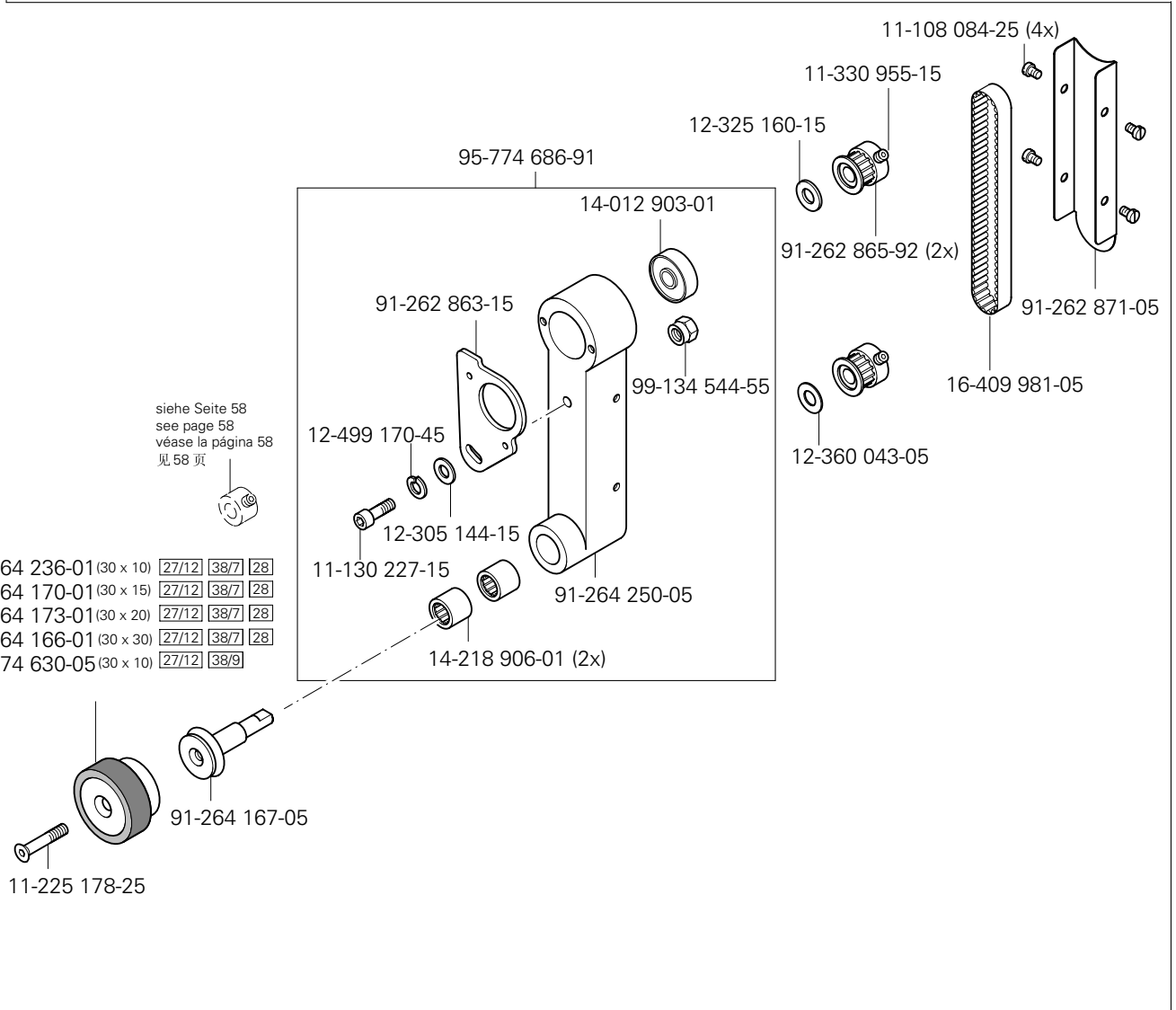
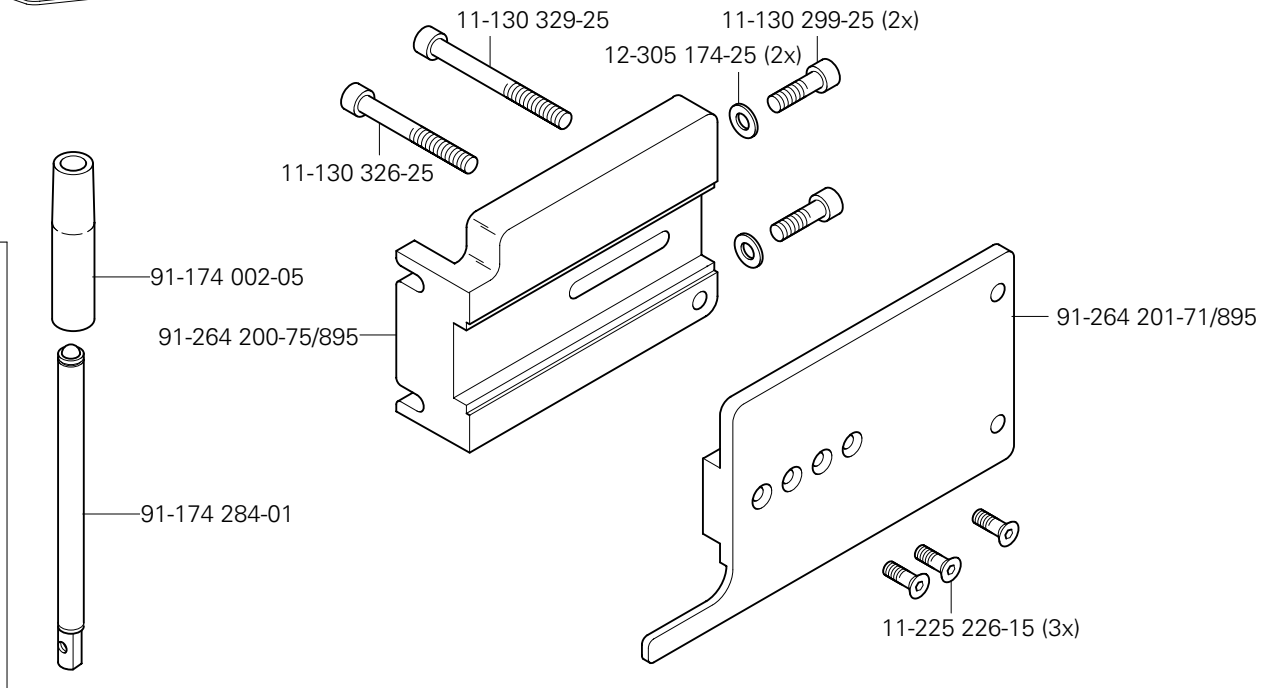

siehe Seite 58
see page 58
véase la página 58
见 58 页

- 91-264 236-01 (30 x 10) [27/12] [38/7] [28]
- 91-264 170-01 (30 x 15) [27/12] [38/7] [28]
- 91-264 173-01 (30 x 20) [27/12] [38/7] [28]
- 91-264 166-01 (30 x 30) [27/12] [38/7] [28]
- 95-774 630-05 (30 x 10) [27/12] [38/9]

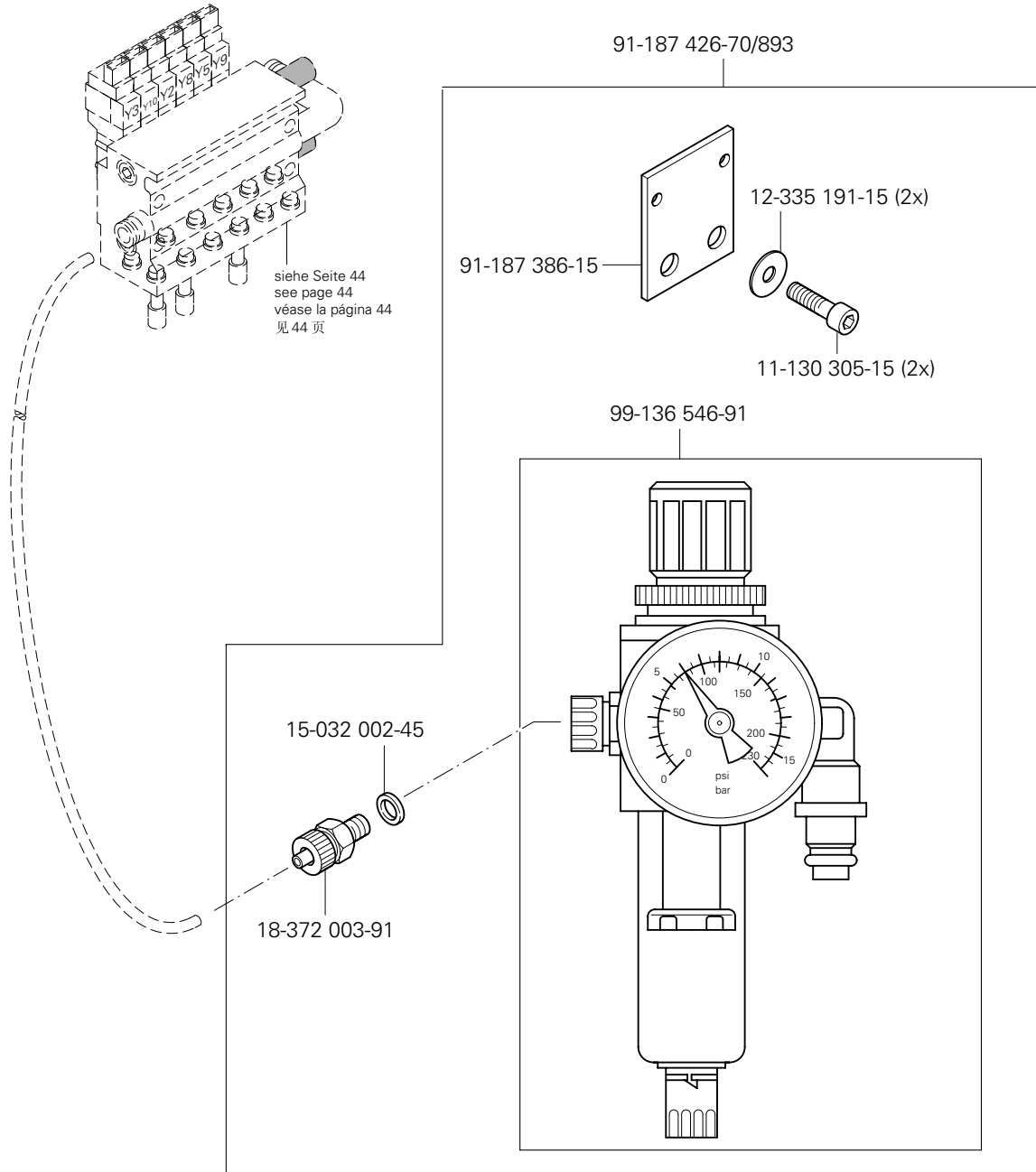
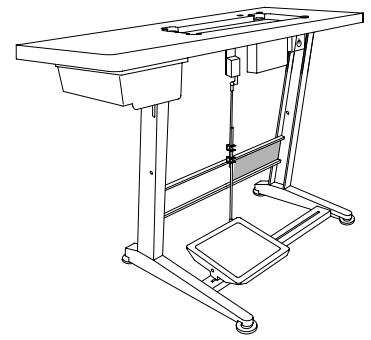

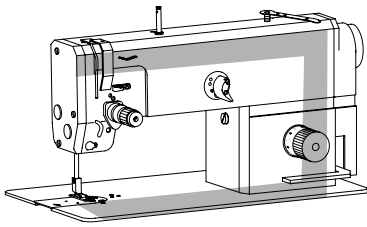

Kabelbaum zum Oberteil

Cable tree to sewing head

Mazo de cables para el cabezal

上部机器电缆束

PFAFF 1181-900/24;1181-D-900/24;1181-G-900/24

PFAFF 1183-900/24;1183-D-900/24;1183-G-900/24

PFAFF 1181-SRP-900/24;1183-SRP-900/24

PFAFF 3701

16.01

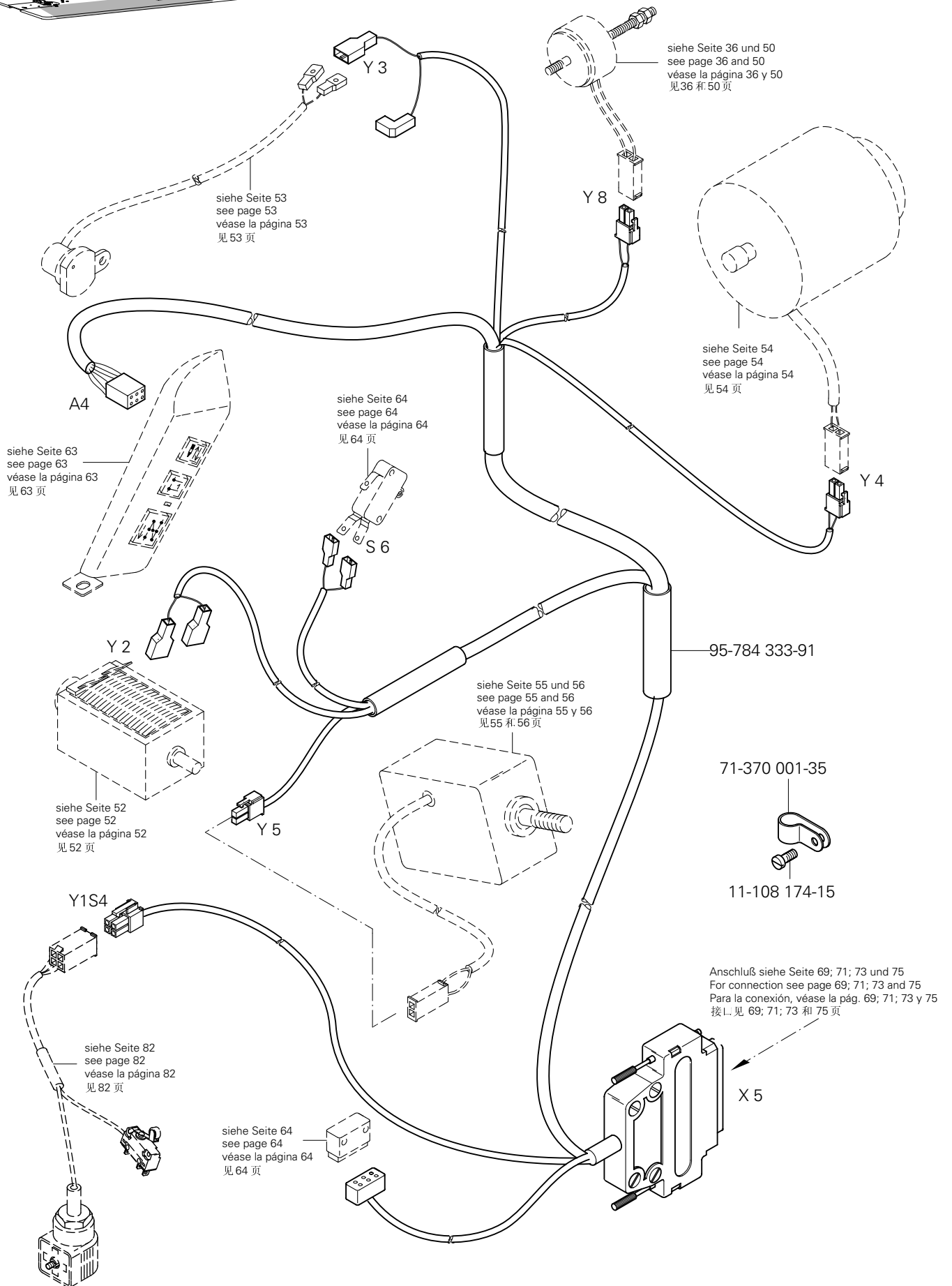

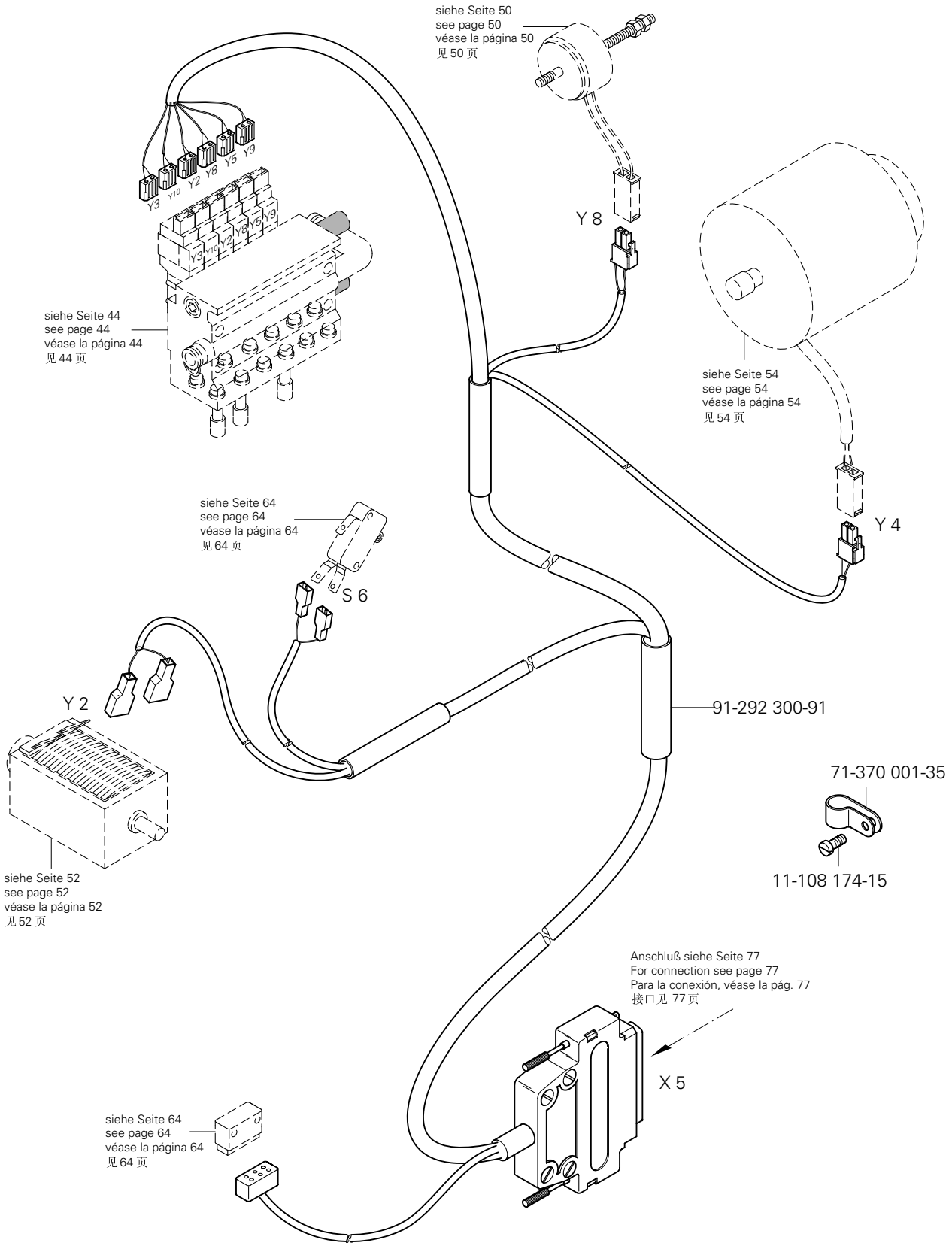
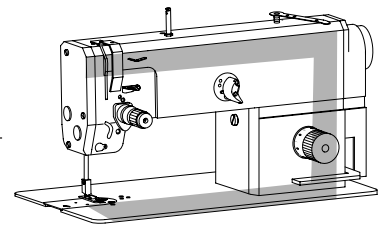

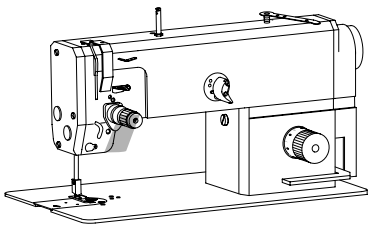

Tastschalter
 Push-button
 Interruptor pulsador
 按钮开关

PFAFF 1181-911/37;1181-D-911/37
 PFAFF 1183-911/37;1183-D-911/37
 PFAFF 3701

16.02

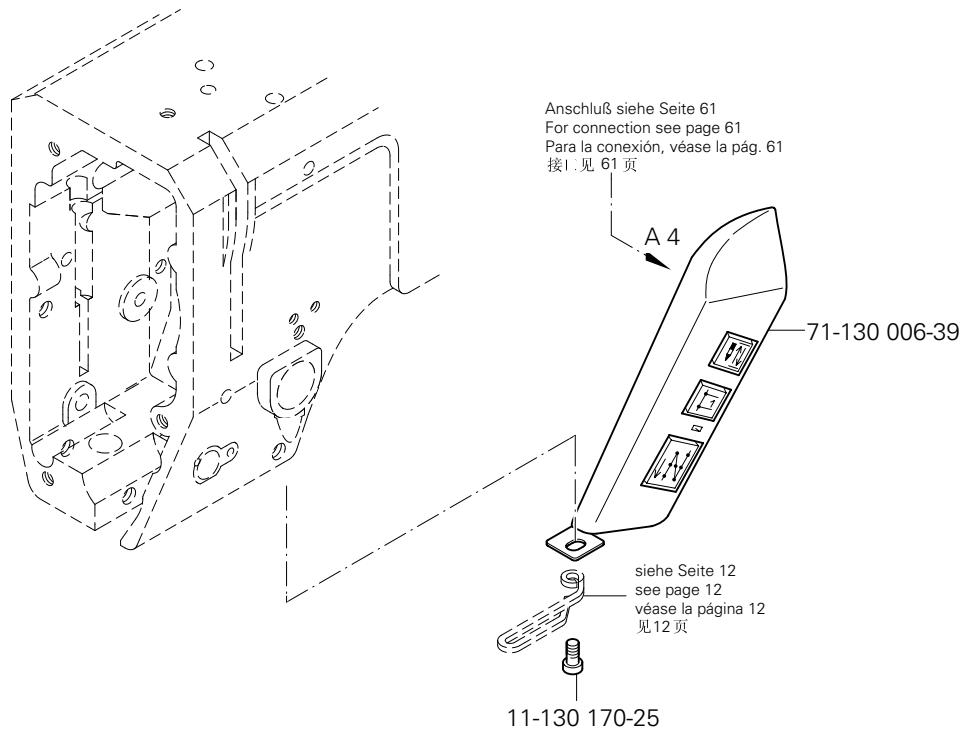

16.03

Oberteilerkennung und Einschaltperre
 Sewing head identification and start inhibitor
 Detección de la parte superior y bloqueo de arranque
 上部机器识别和起动闭锁

PFAFF 1181-900/24
 PFAFF 1183-900/24
 PFAFF 3511-2/01
 PFAFF 3701-4/11

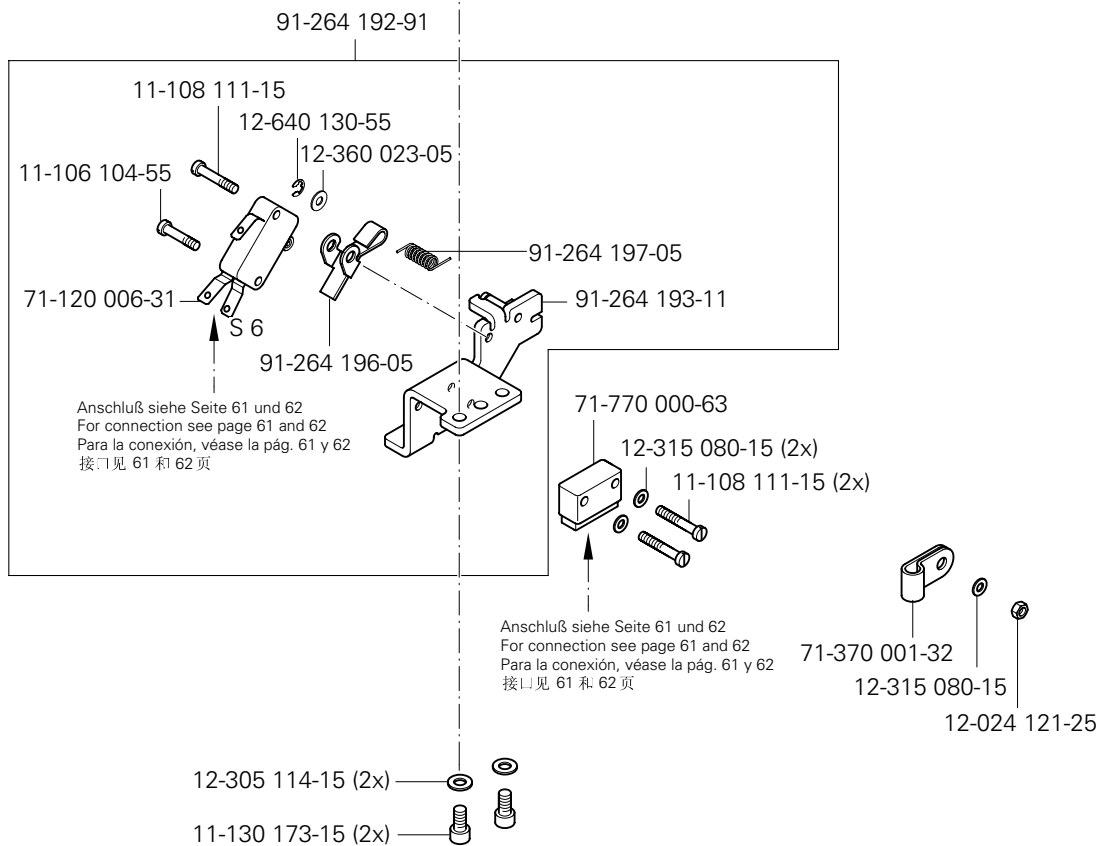
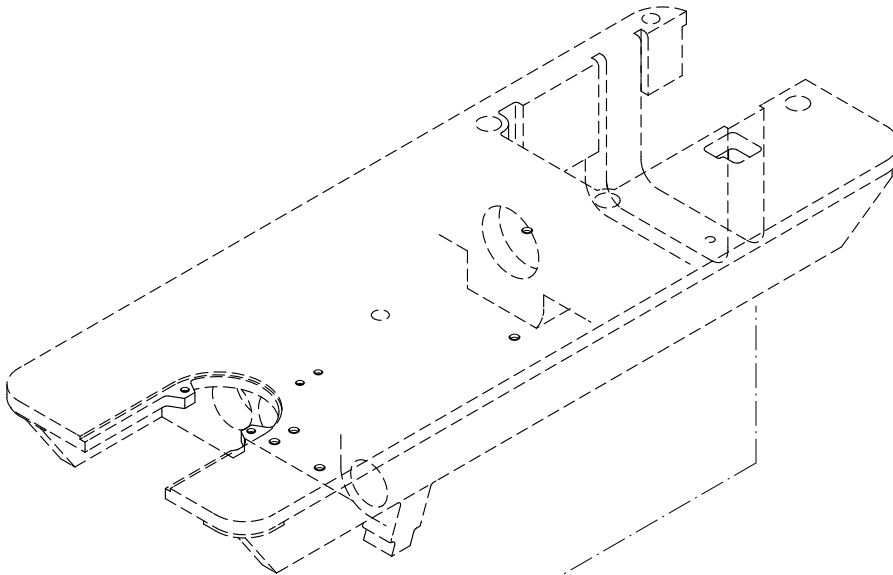
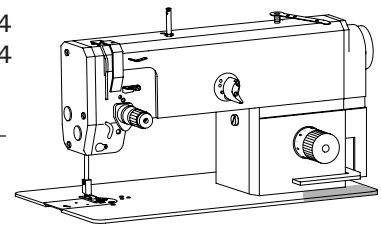

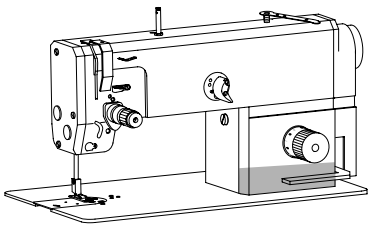

Einbaumotor
Built-in motor
Motor incorporado
内装式电机

PFAFF 1181-900/24
PFAFF 1183-900/24
PFAFF 3511-2/01
PFAFF 3701-4/11

16.04

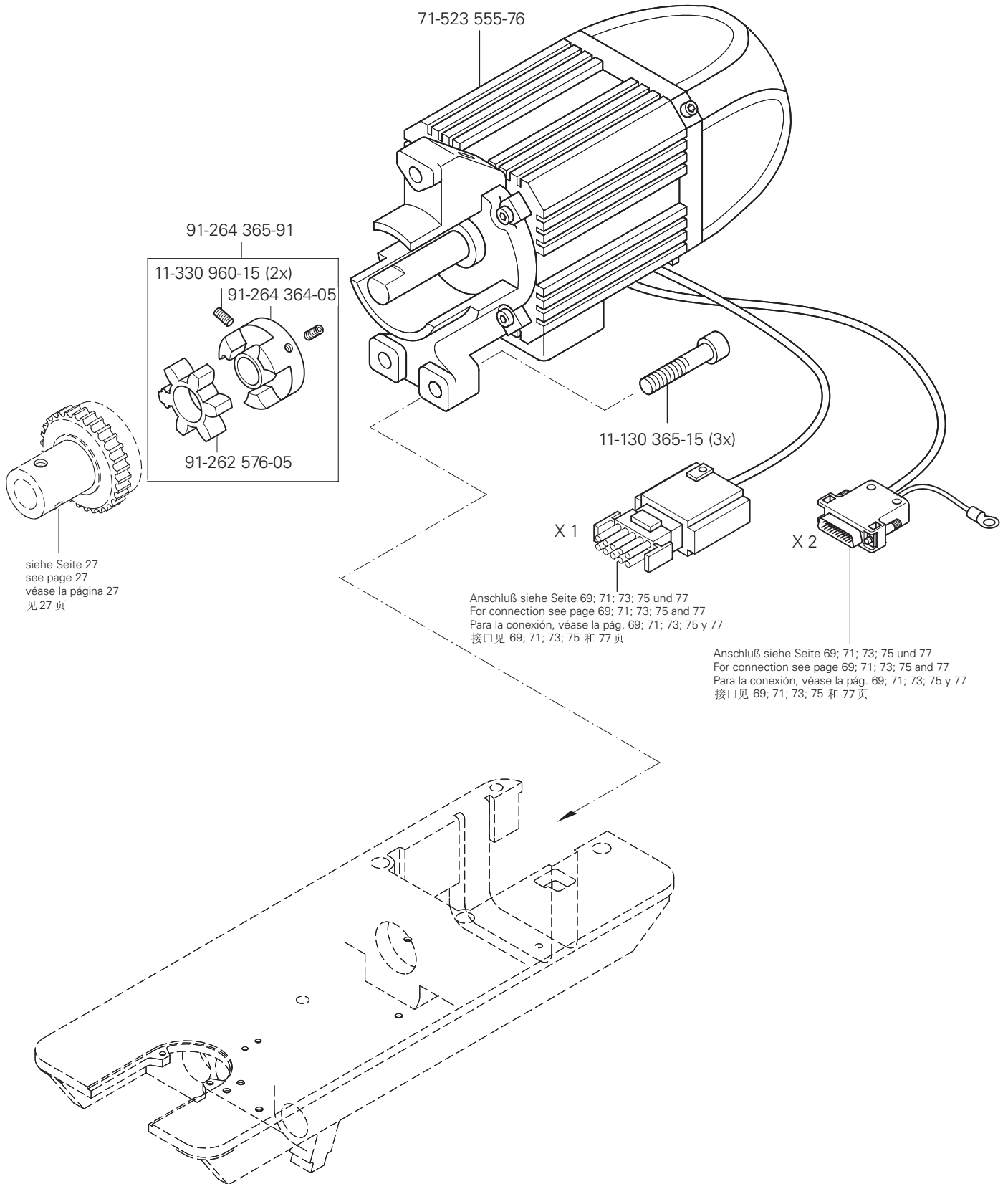

16.05

Motor-Hauptschalter
Main switch
Interruptor principal
电机主开关

PFAFF 1181
PFAFF 1183
PFAFF 3511
PFAFF 3701

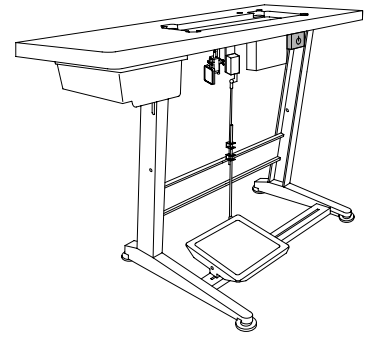

71-370 001-08



Anschluß siehe Seite 71; 73; 75 und 77
For connection see page 71; 73; 75 and 77
Para la conexión, véase la pág. 71; 73; 75 y 77
接口见 71; 73; 75 和 77 页



11-460 163-15



71-370 002-92

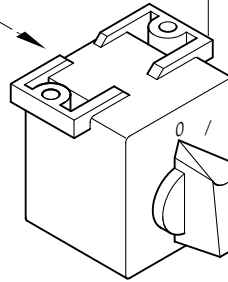

91-229 180-90 90/1



11-460 250-15 (2x)

16.06

Knietaster mit Leitung
Knee switch with cable
Interruptor de rodillera con cable
带电缆膝键

PFAFF1181 SRP-900/24
PFAFF1183 SRP-900/24

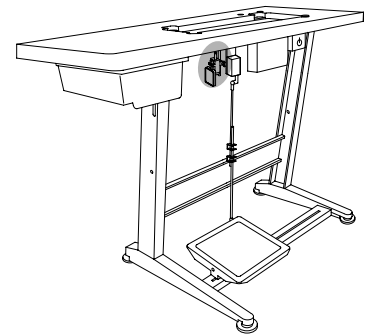

91-091 606-91

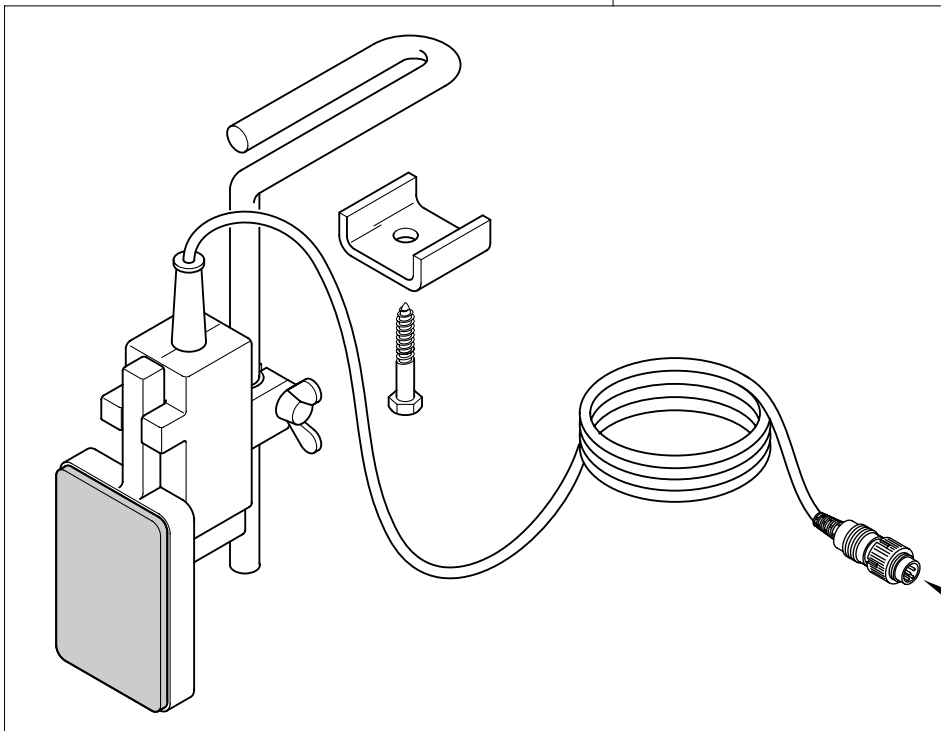

Anschluß siehe
For connection :
Para la conexión :
接口见 35 页

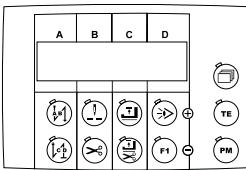
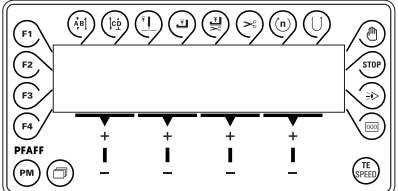
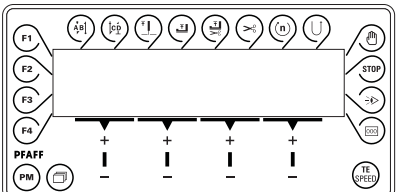
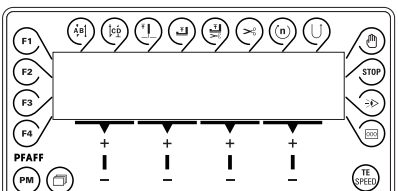
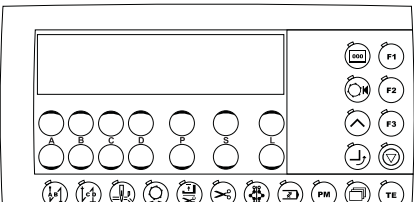
<p>Klasse Class Clase 机型</p>	<p>Steuerungspaket Control package Paquete de control 控制组件</p>	<p>Abbildung siehe Seite: Stitching margin Margen de costura 图见页号</p>
<p>1181; 1183 Quick-PicoTop</p> 	<p>Quick-PicoDrive mit P40PD Best.-Nr. Part number N° de pedido 订货号</p> <p>74-086 502-91</p>	<p>68; 69</p>
<p>1181; 1183 Quick-BDF S2</p> 	<p>Quick-EcoDrive mit P40ED-A Best.-Nr. Part number N° de pedido 订货号</p> <p>71-590 007-84</p>	<p>70; 71</p>
<p>1181-SRP; 1183-SRP Quick-BDF S2</p> 	<p>Quick-EcoDrive mit P50ED Best.-Nr. Part number N° de pedido 订货号</p> <p>71-590 007-89</p>	<p>72; 73</p>
<p>1181-948/26; 1183-948/26; 3701 Quick-BDF S2</p> 	<p>Quick-EcoDrive mit P350ED Best.-Nr. Part number N° de pedido 订货号</p> <p>71-590 008-35</p>	<p>74; 75</p>
<p>3511 Quick-BDF S3</p> 	<p>Quick-EcoDrive mit P310ED-A Best.-Nr. Part number N° de pedido 订货号</p> <p>71-590 008-33</p>	<p>76; 77</p>

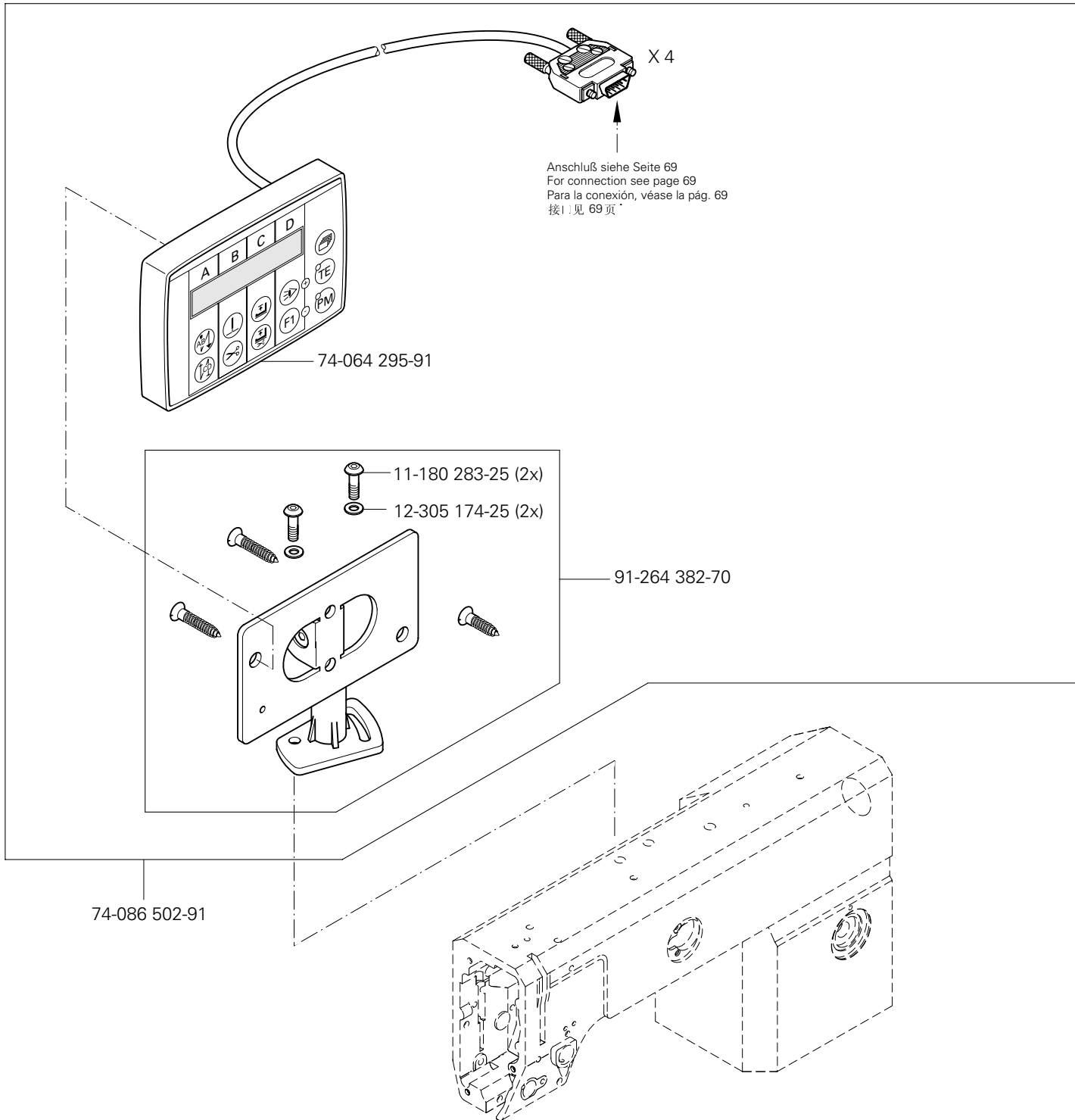
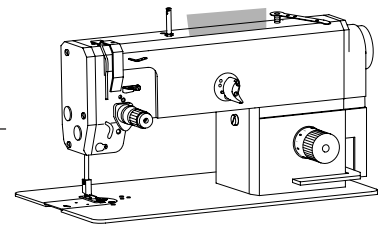

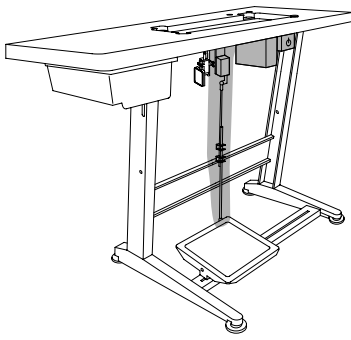

Steuerungspaket Quick-PicoDrive mit P40 PD
 Control package Quick-PicoDrive with P40 PD
 Paquete de control Quick-PicoDrive con P40 PD
 控制组件 Quick-PicoDrive 带 P40 PD

PFAFF 1181
 PFAFF 1183

16.08

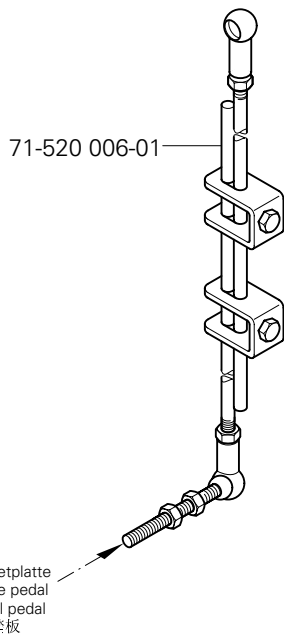
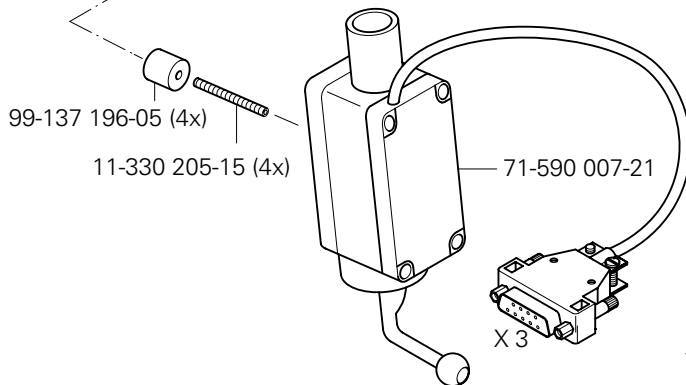
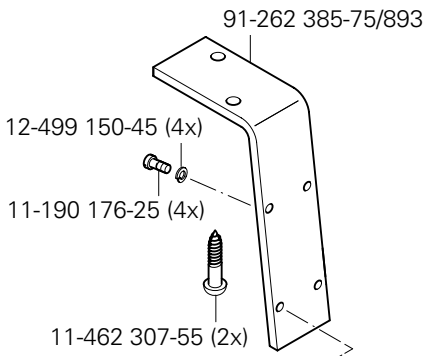

- X 1 Anschluß siehe Seite 65
For connection see page 65
Para la conexión, véase la pág. 65
接口见 65 页
- X 5 Anschluß siehe Seite 61
For connection see page 61
Para la conexión, véase la pág. 61
接口见 61 页
- X 4 Anschluß siehe Seite 68
For connection see page 68
Para la conexión, véase la pág. 68
接口见 68 页
- X 2 Anschluß siehe Seite 65
For connection see page 65
Para la conexión, véase la pág. 65
接口见 65 页

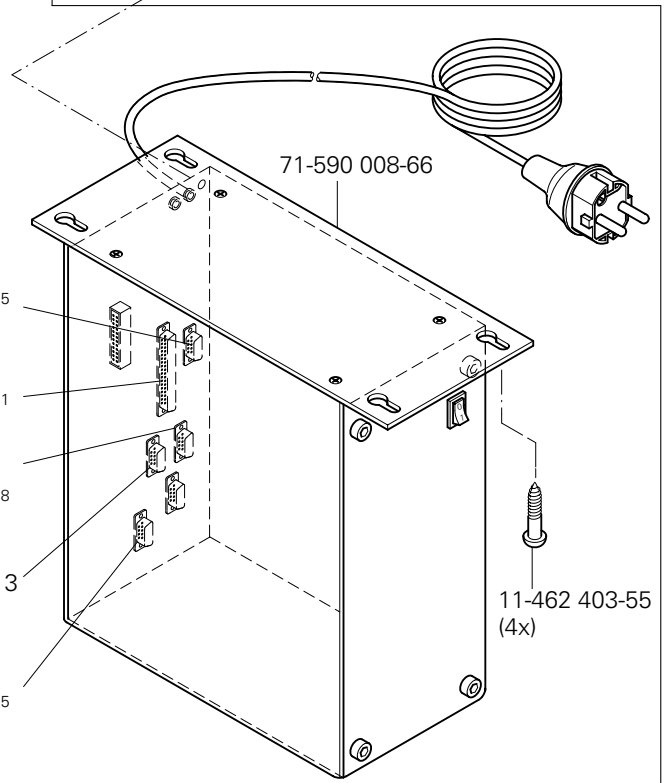
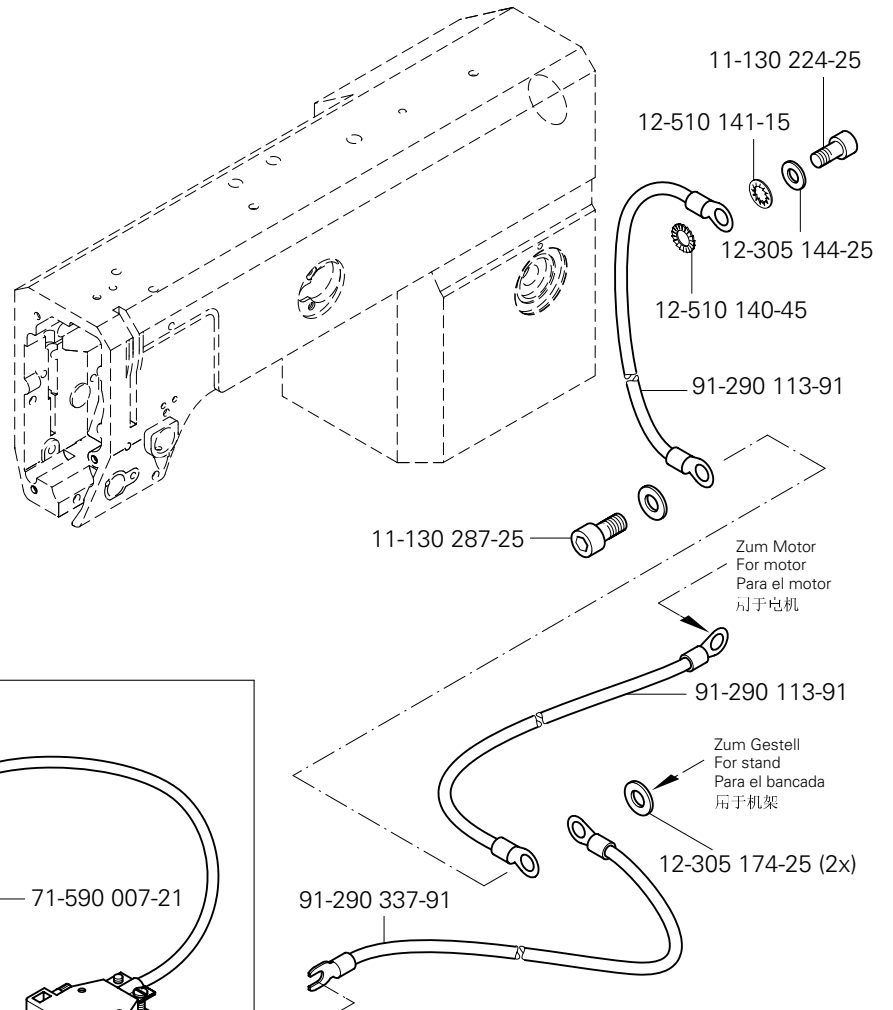

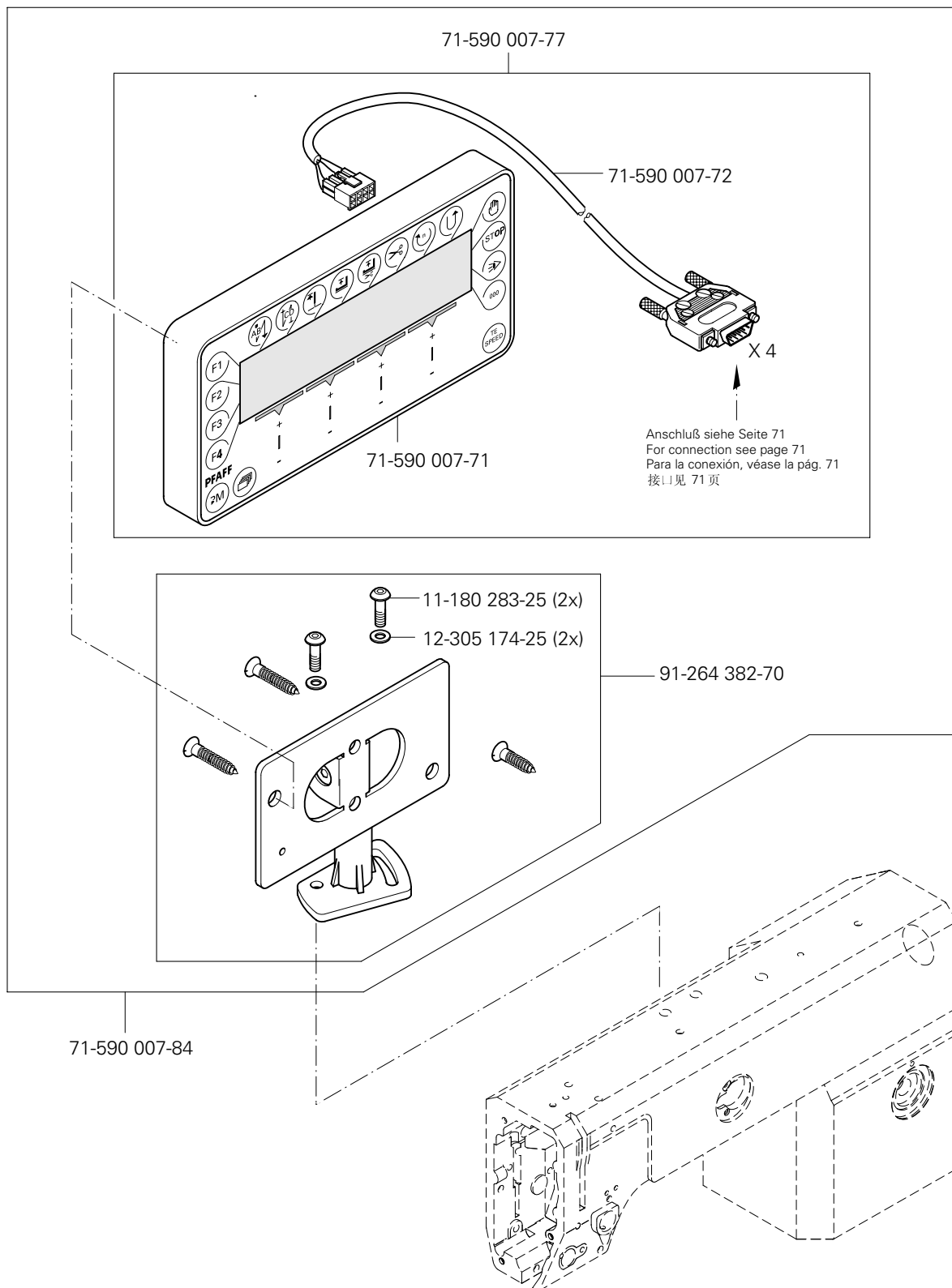
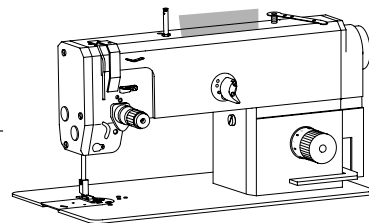

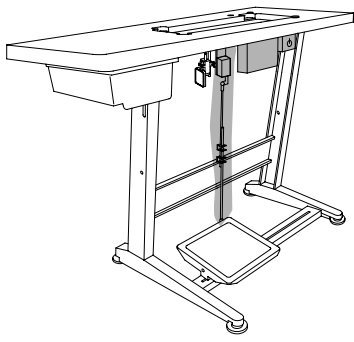

Steuerungspaket Quick-EcoDrive mit P40 ED-A
 Control package Quick-EcoDrive with P40 ED-A
 Paquete de control Quick-EcoDrive con P40 ED-A
 控制组件 Quick-EcoDrive 带 P40 ED-A

PFAFF 1181
 PFAFF 1183

16.09

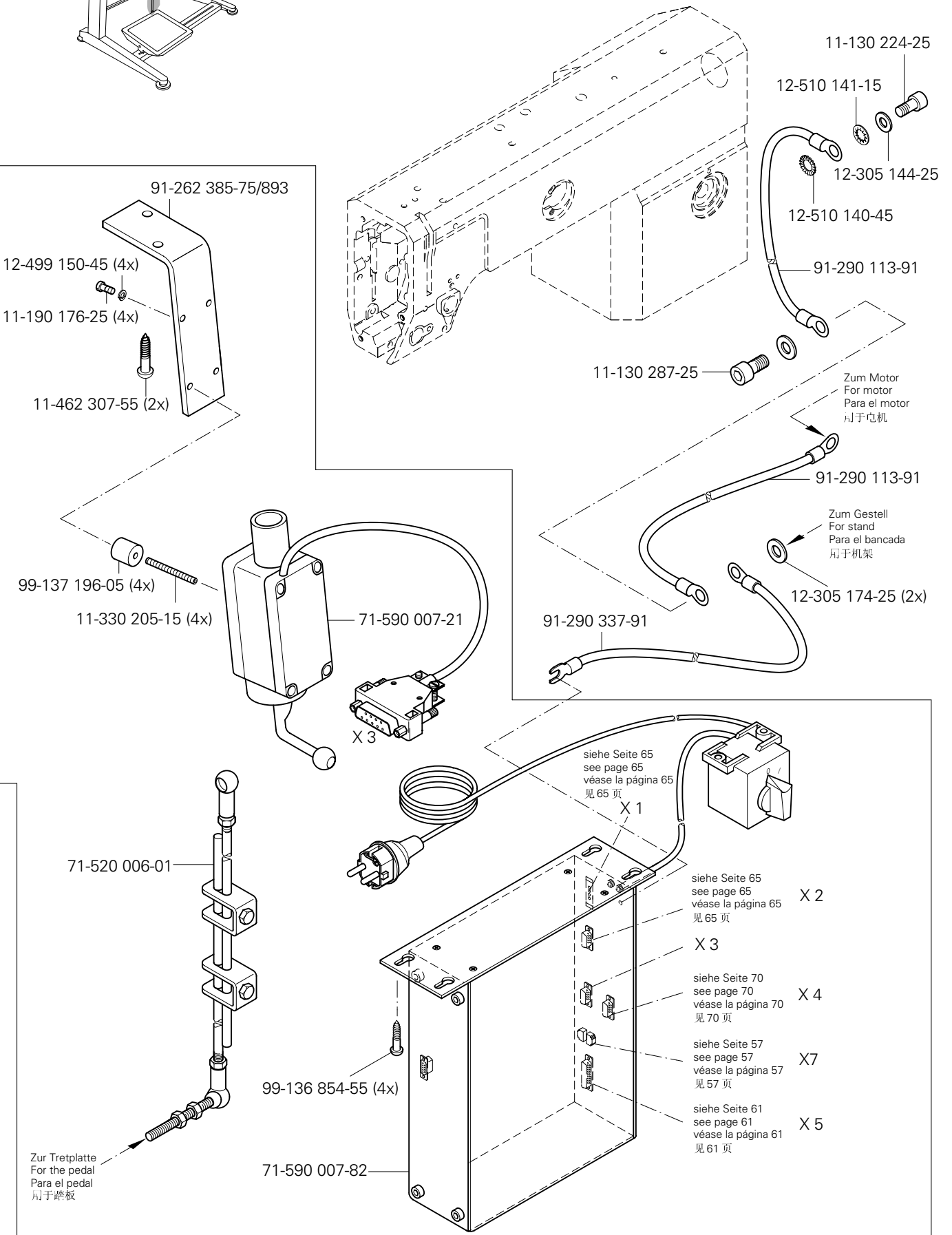

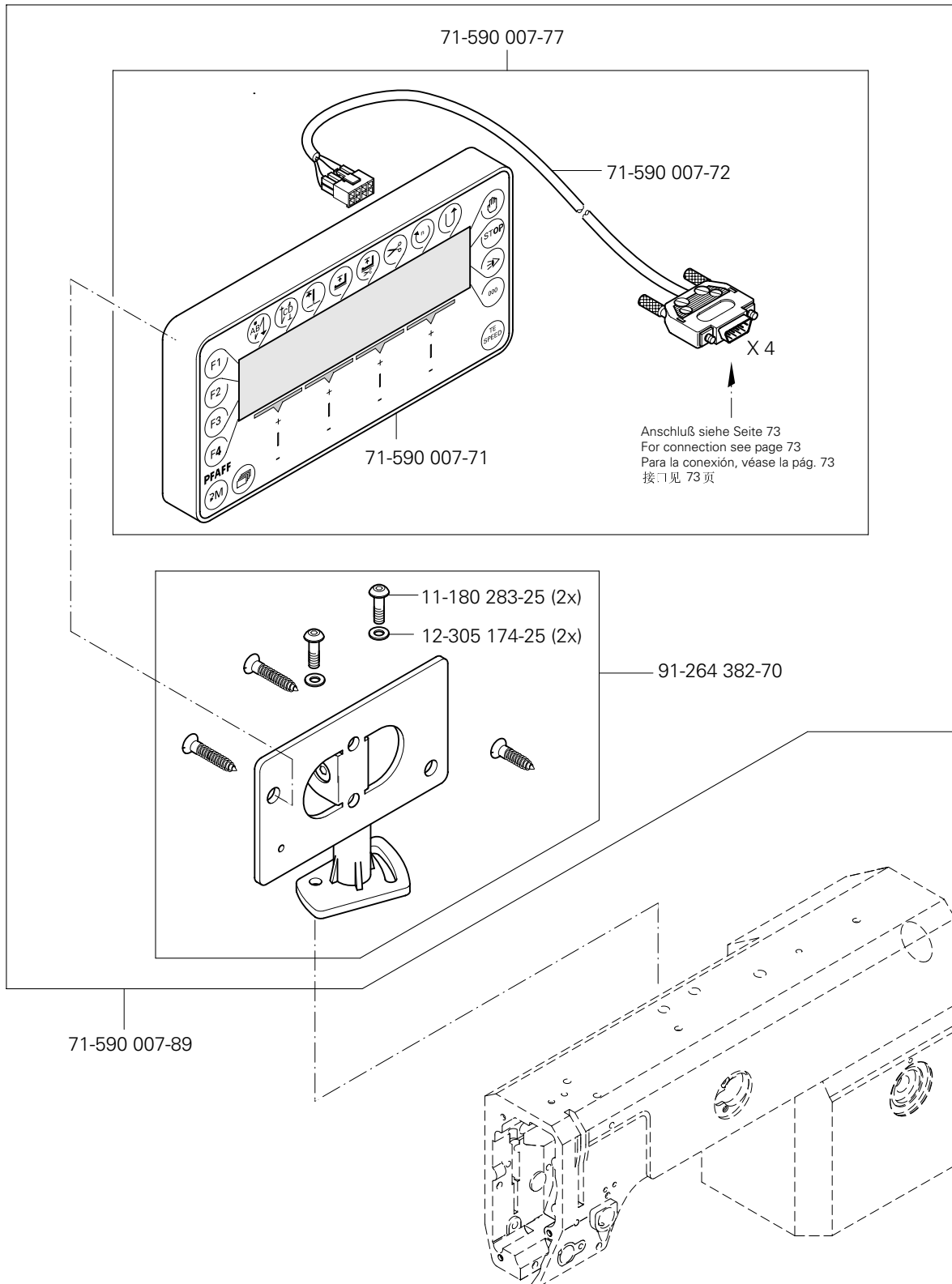
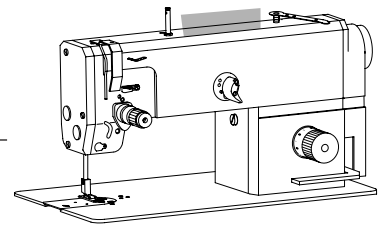

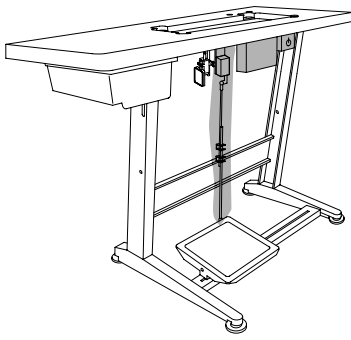

Steuerungspaket Quick-EcoDrive mit P50 ED
 Control package Quick-EcoDrive with P50 ED
 Paquete de control Quick-EcoDrive con P50 ED
 控制组件 Quick-EcoDrive 带 P50 ED

PFAFF 1181-SRP
 PFAFF 1183-SRP

16.10

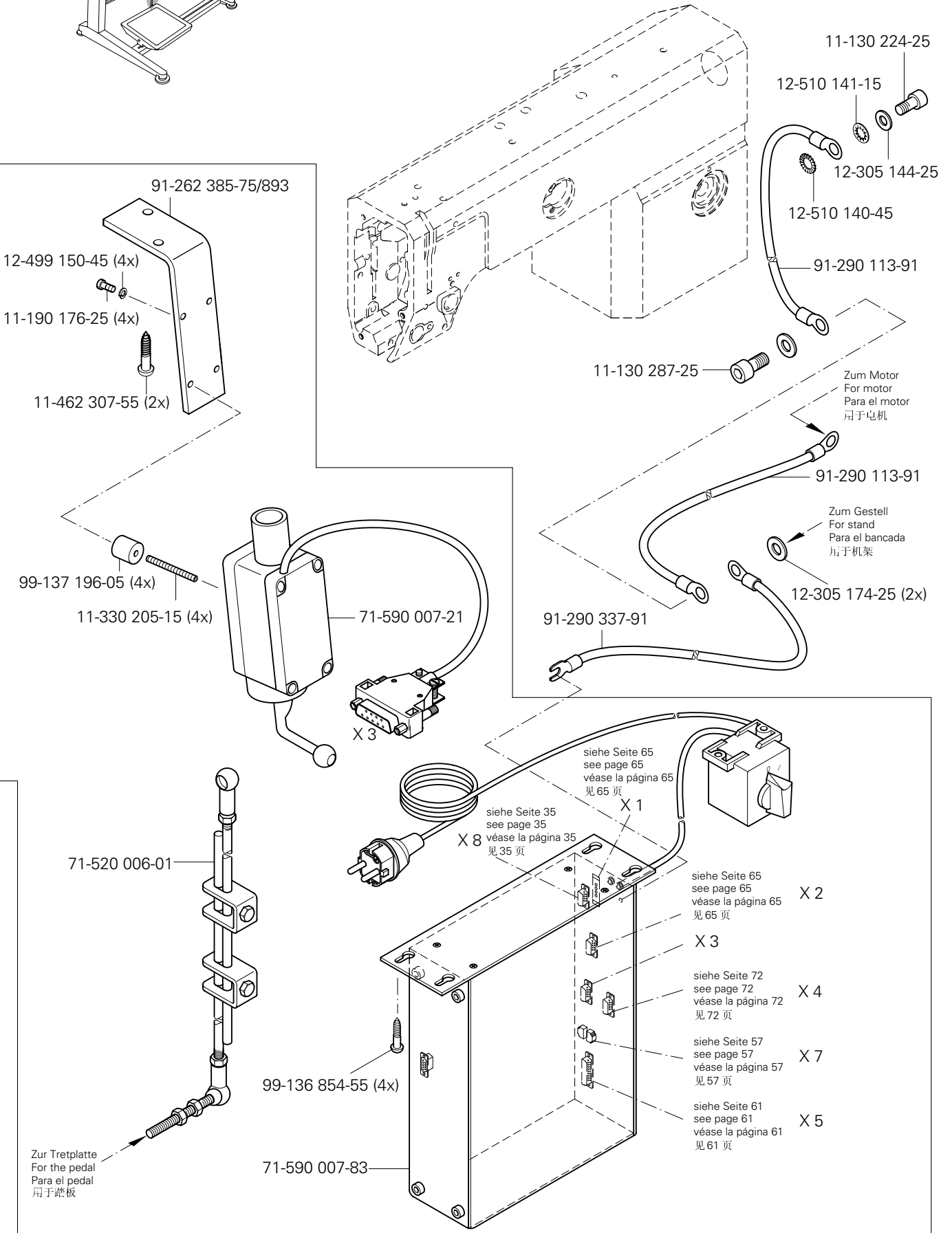

16.11

Steuerungspaket Quick-EcoDrive mit P350 ED
 Control package Quick-EcoDrive with P350 ED
 Paquete de control Quick-EcoDrive con P350 ED
 控制组件 Quick-EcoDrive 带 P350 ED

PFAFF 1181-948/26
 PFAFF 1183-948/26
 PFAFF 3701

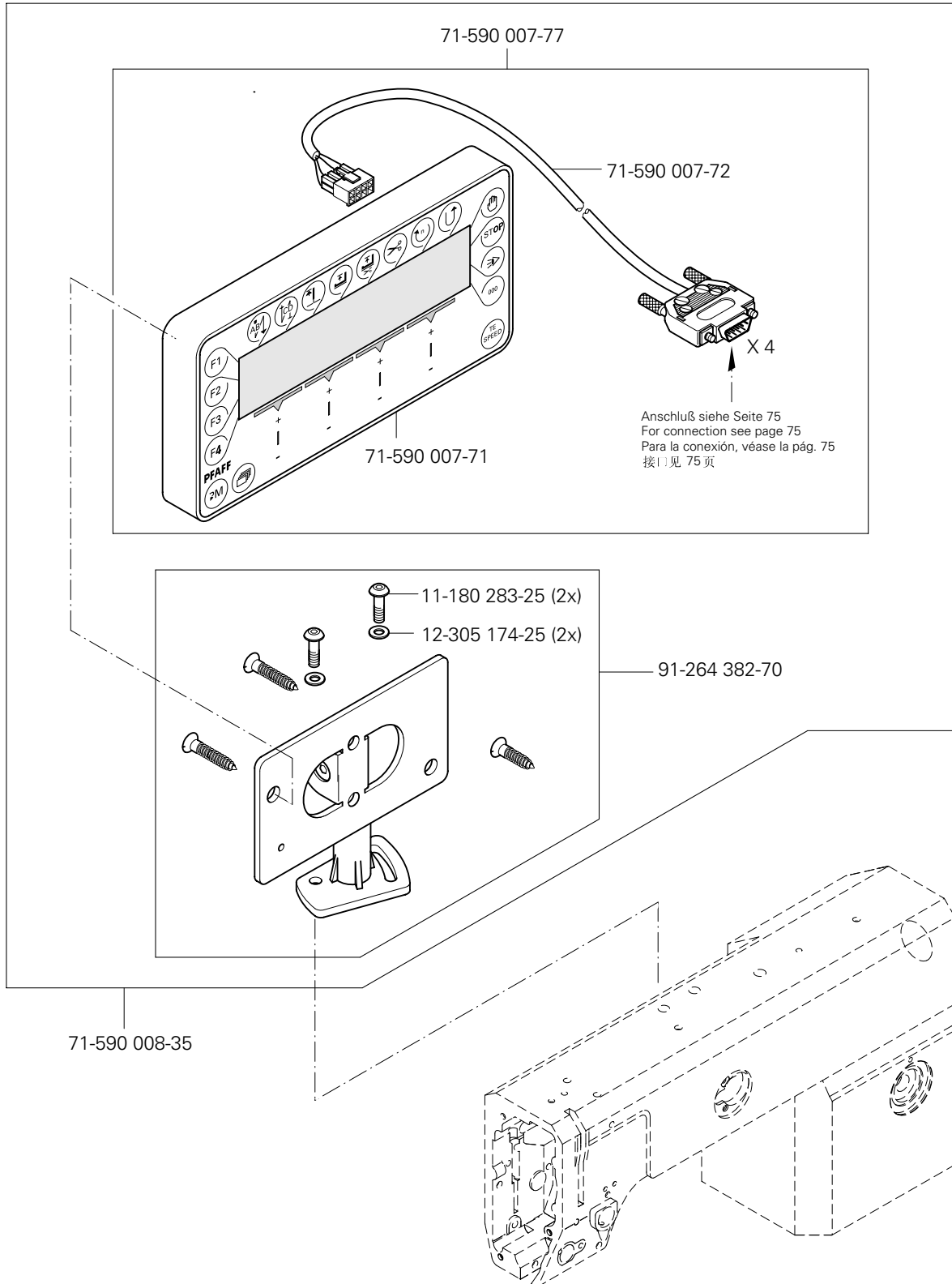
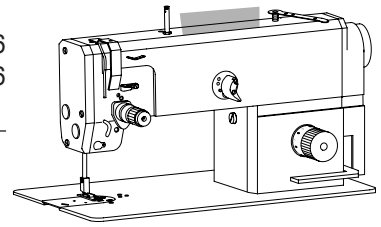

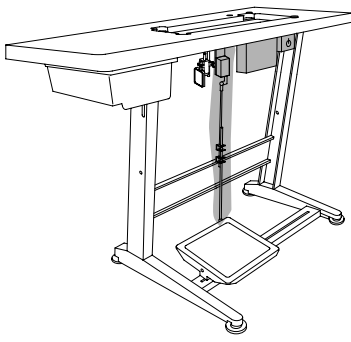

Steuerungspaket Quick-EcoDrive mit P350 ED
 Control package Quick-EcoDrive with P350 ED
 Paquete de control Quick-EcoDrive con P350 ED
 控制组件 Quick-EcoDrive 带 P350 ED

PFAFF 1181-948/26
 PFAFF 1183-948/26
 PFAFF 3701

16.11

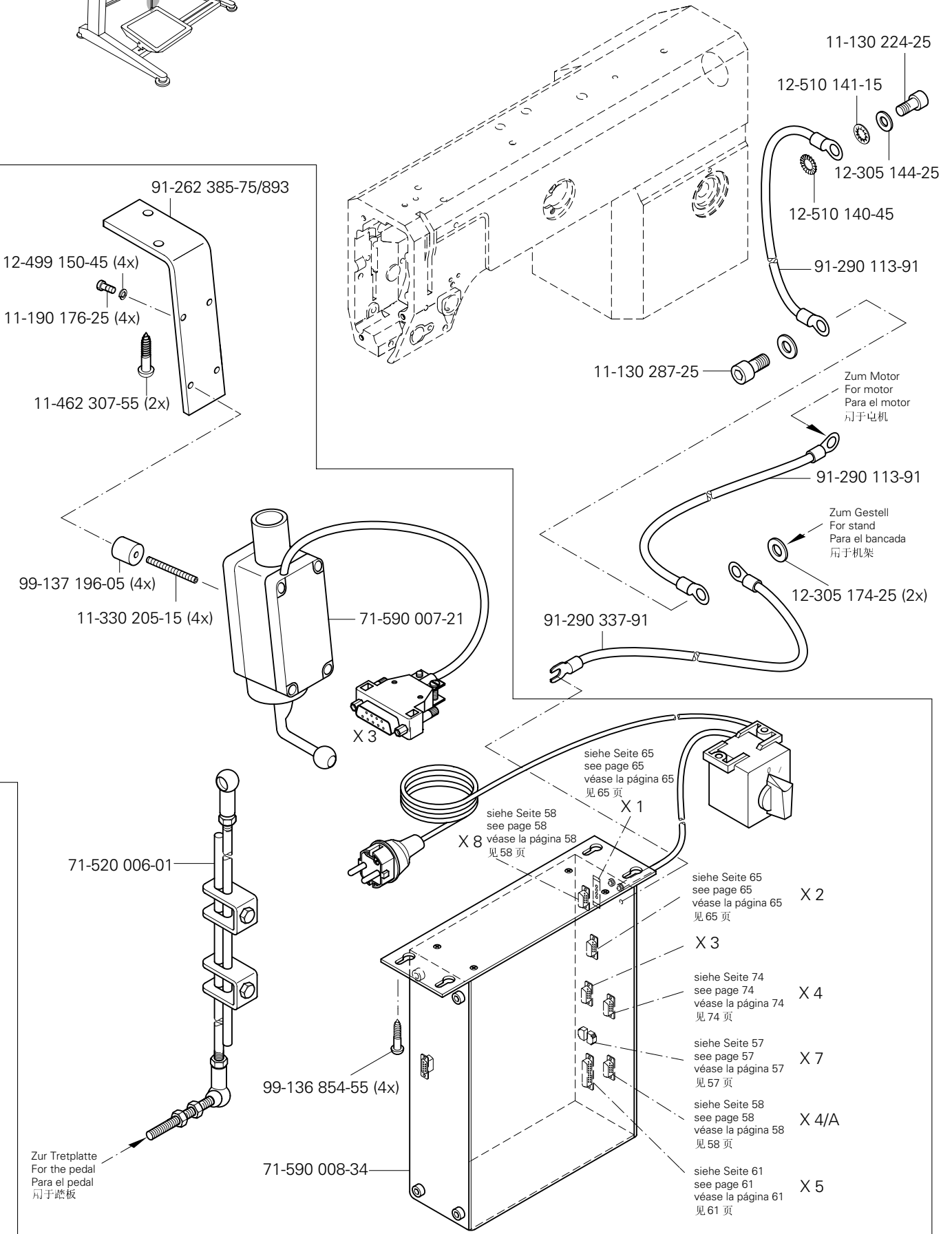

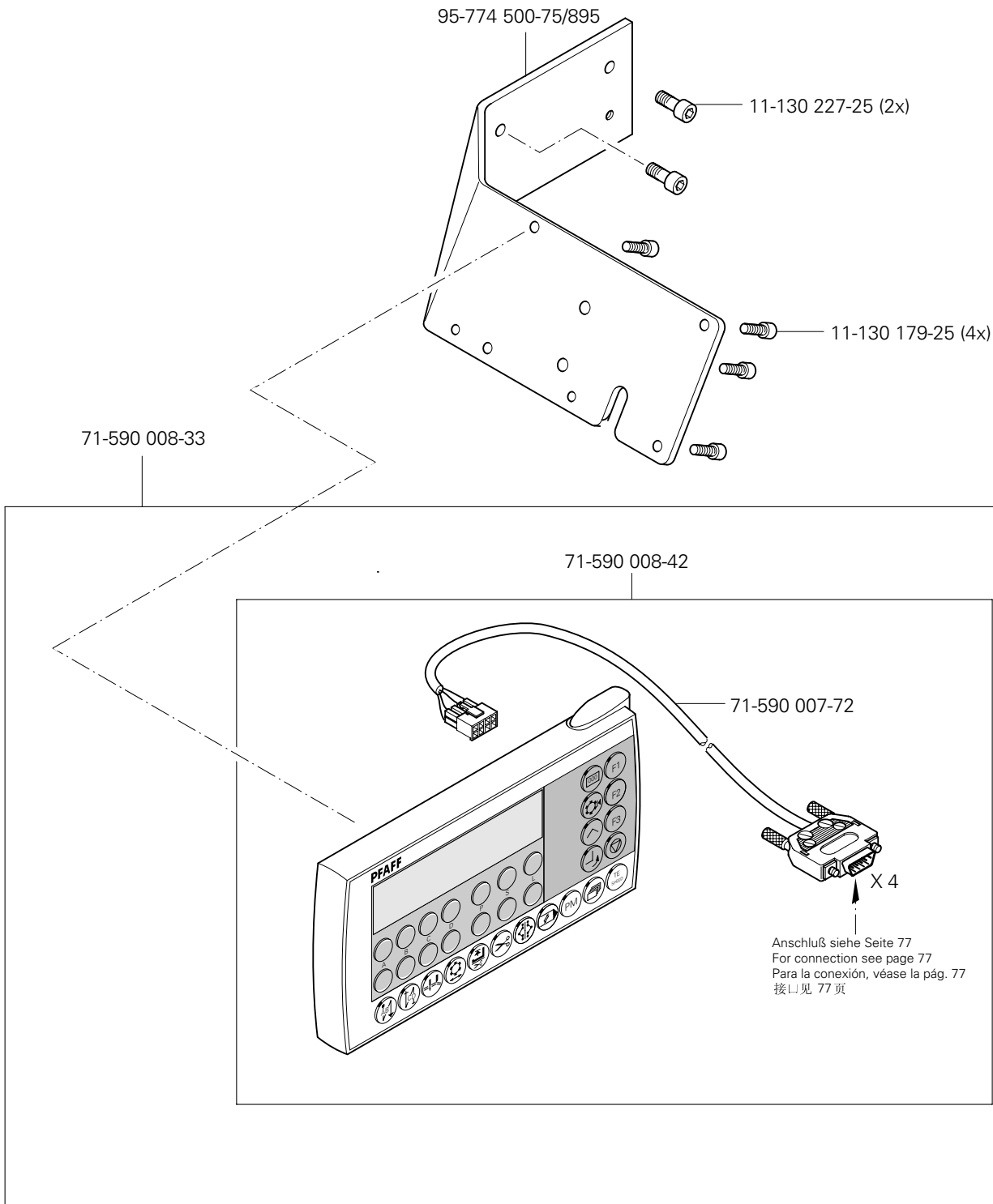
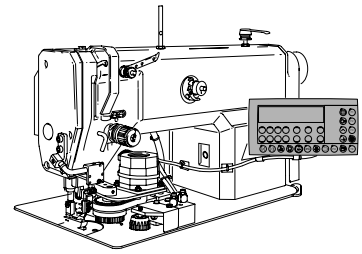

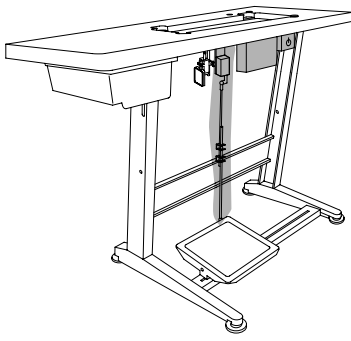

Steuerungspaket Quick-EcoDrive mit P310 ED-A
 Control package Quick-EcoDrive with P310 ED-A
 Paquete de control Quick-EcoDrive con P310 ED-A
 控制组件 Quick-EcoDrive 带 P310 ED-A

PFAFF 3511

16.12

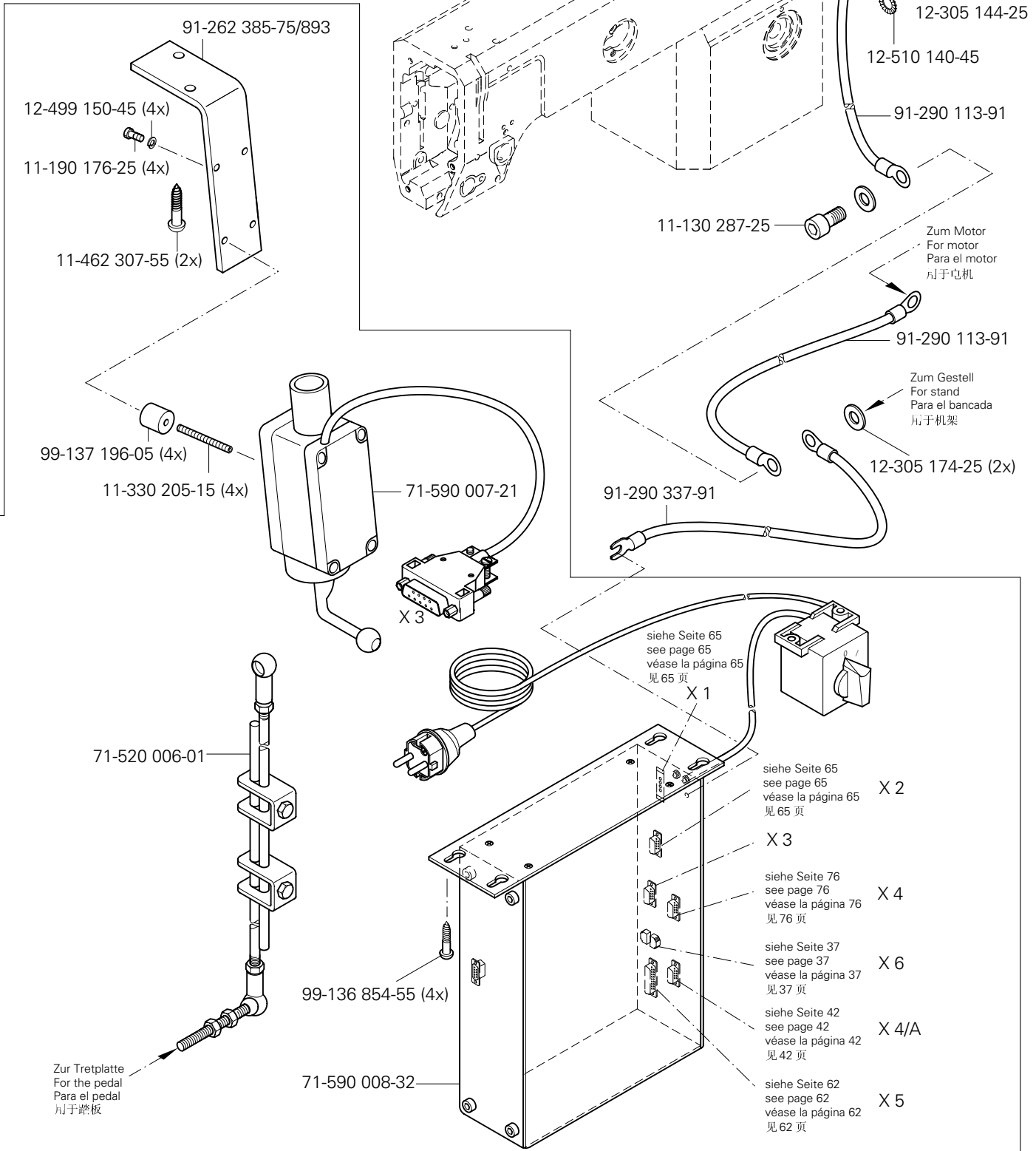

91-229 070-70/895

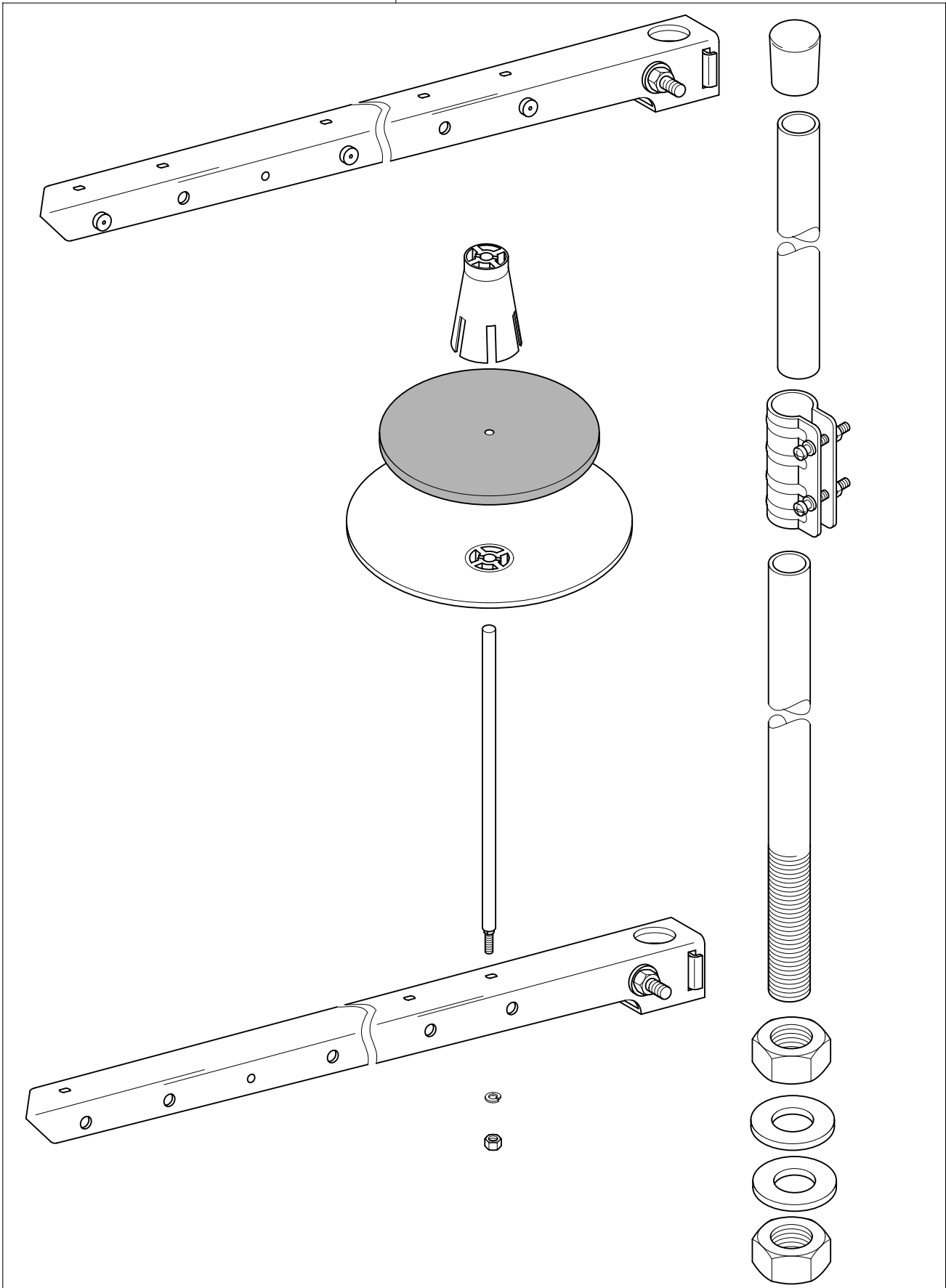

Einstellehren PFAFF 1181;1181- D
 Adjustment gauges PFAFF 1183;1183- D
 Calibres de ajuste PFAFF 3511-2/01
 设置量规 PFAFF 3701-4/11

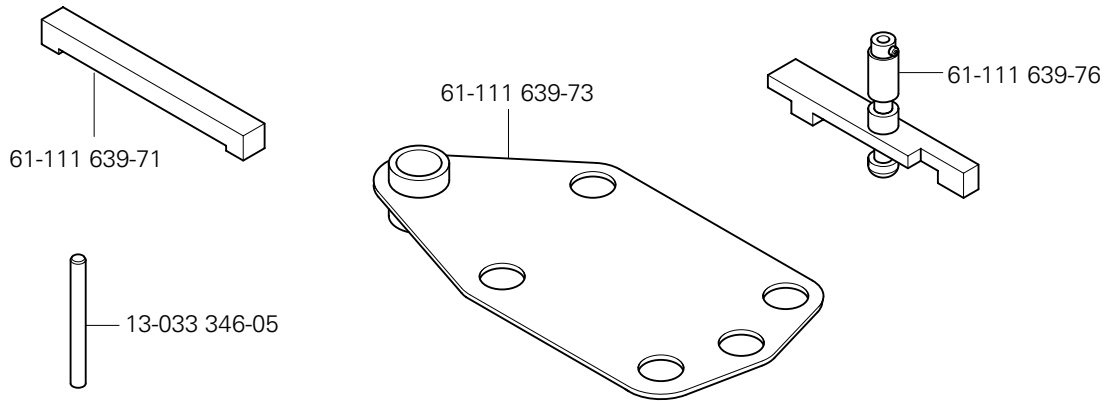

Teile zur Tischplatte PFAFF 1181;1181- D
 Parts for table top PFAFF 1183;1183- D
 Piezas para el tablero PFAFF 3511-2/01
 用于台板的零件 PFAFF 3701-4/11

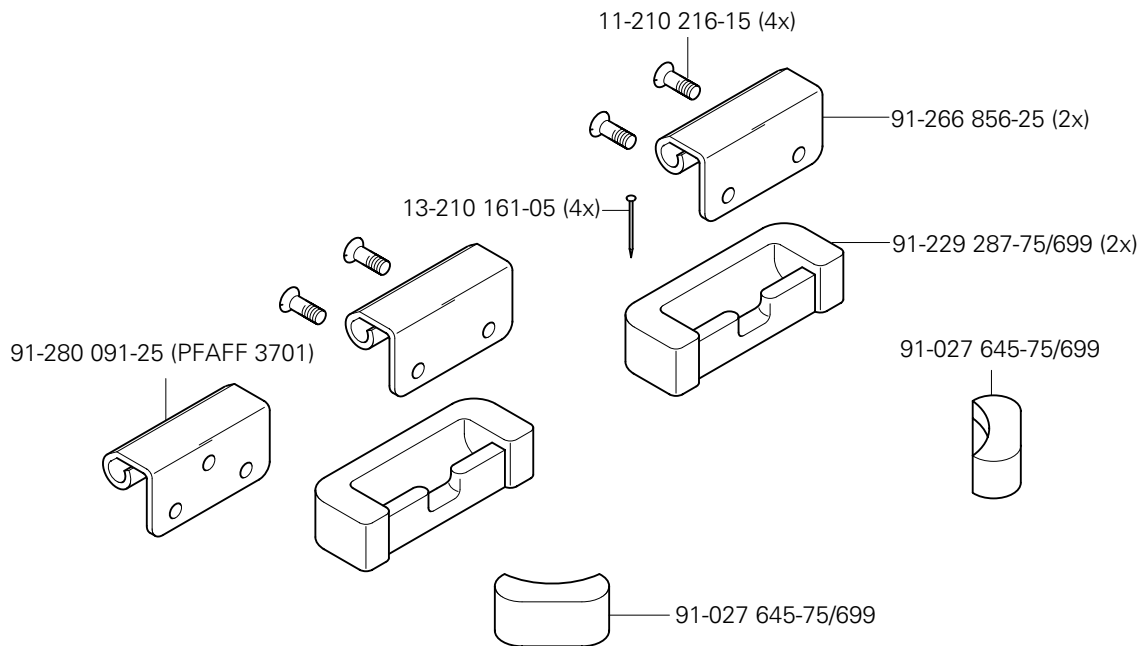

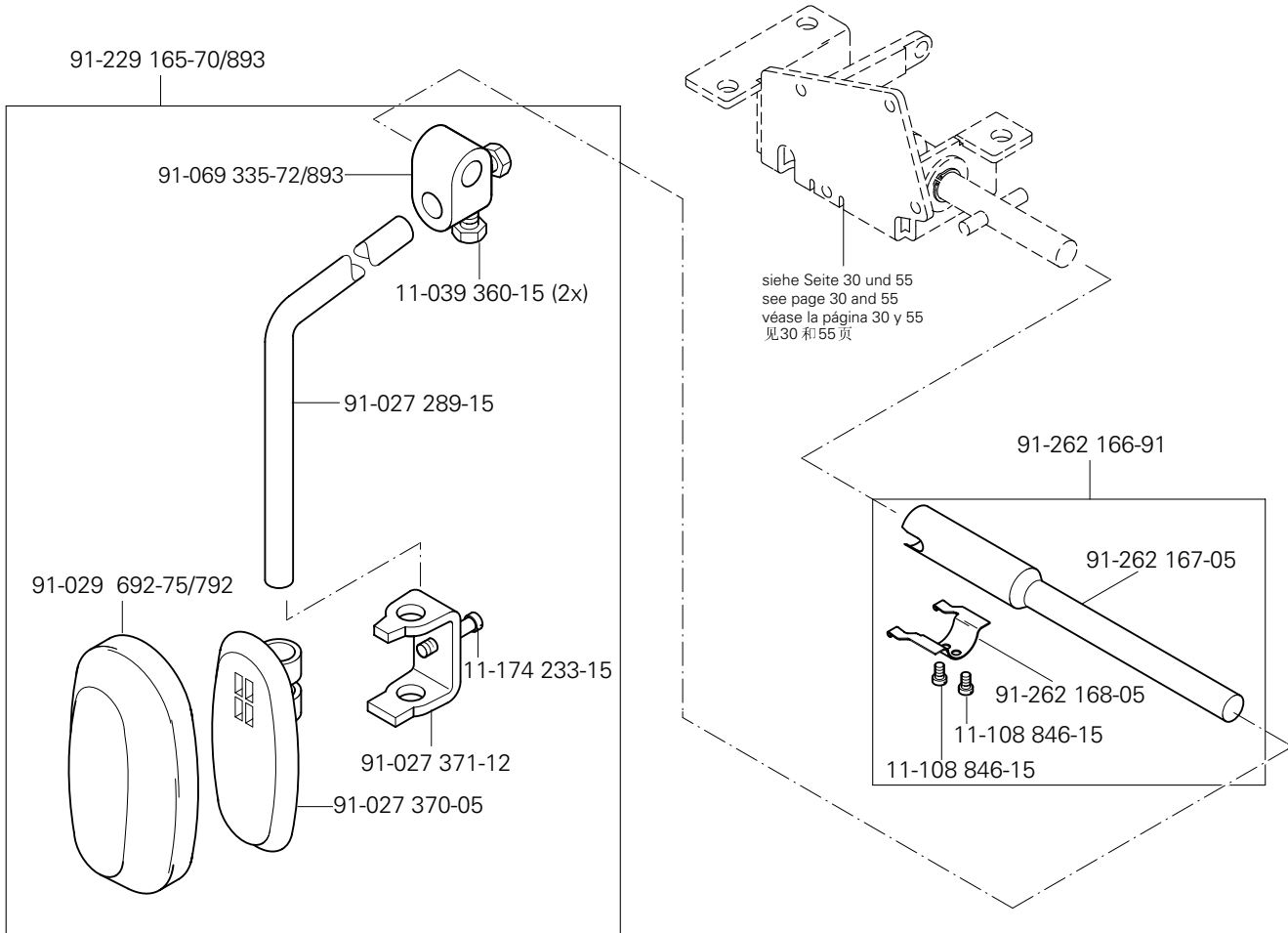
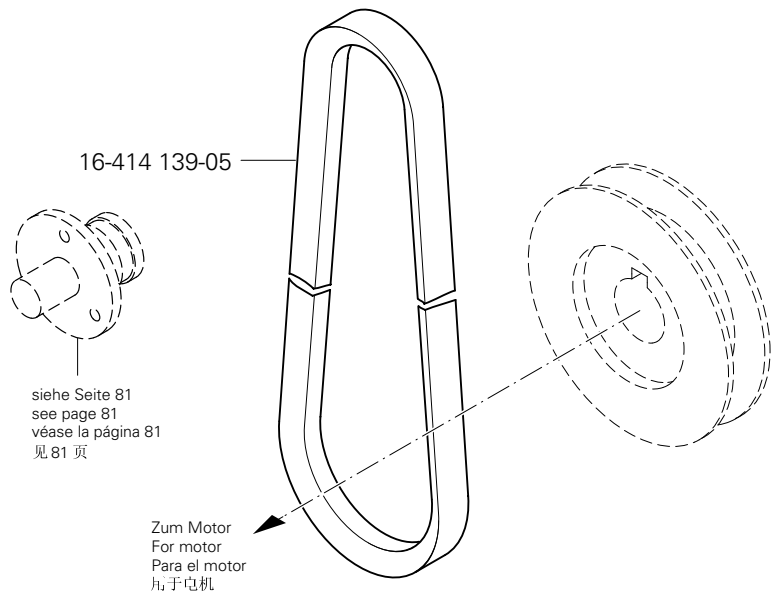

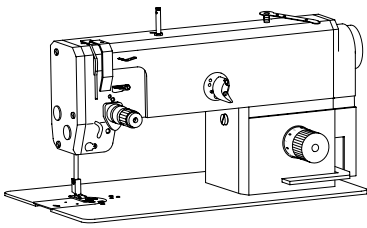

Anbausatz für externen Motor
 Mounting kit for external motor

Juego de piezas acoplables para motor externo
 外部电机安装组件

PFAFF 1181;1183
 PFAFF 1181- D ;1183- D

22.01

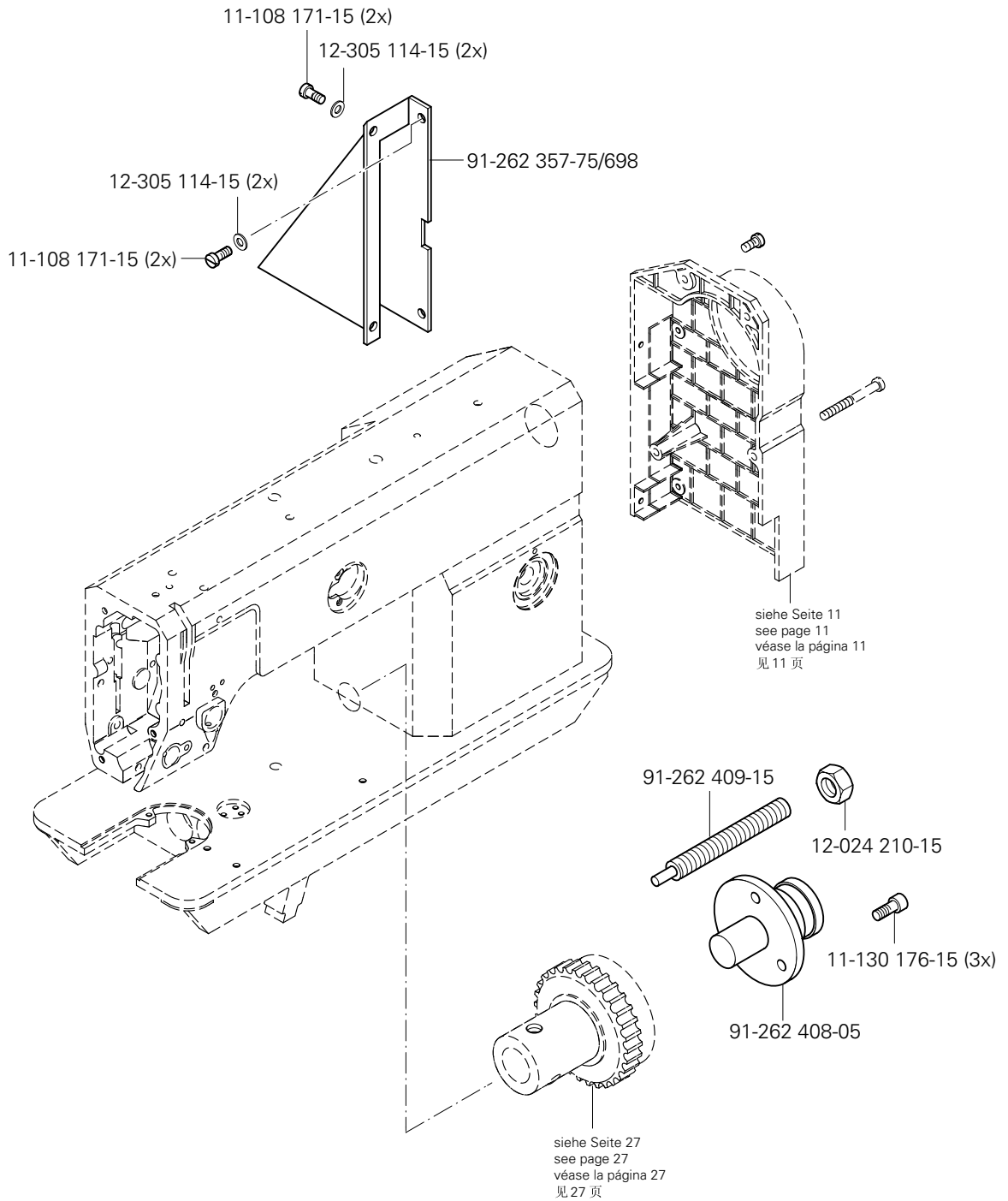

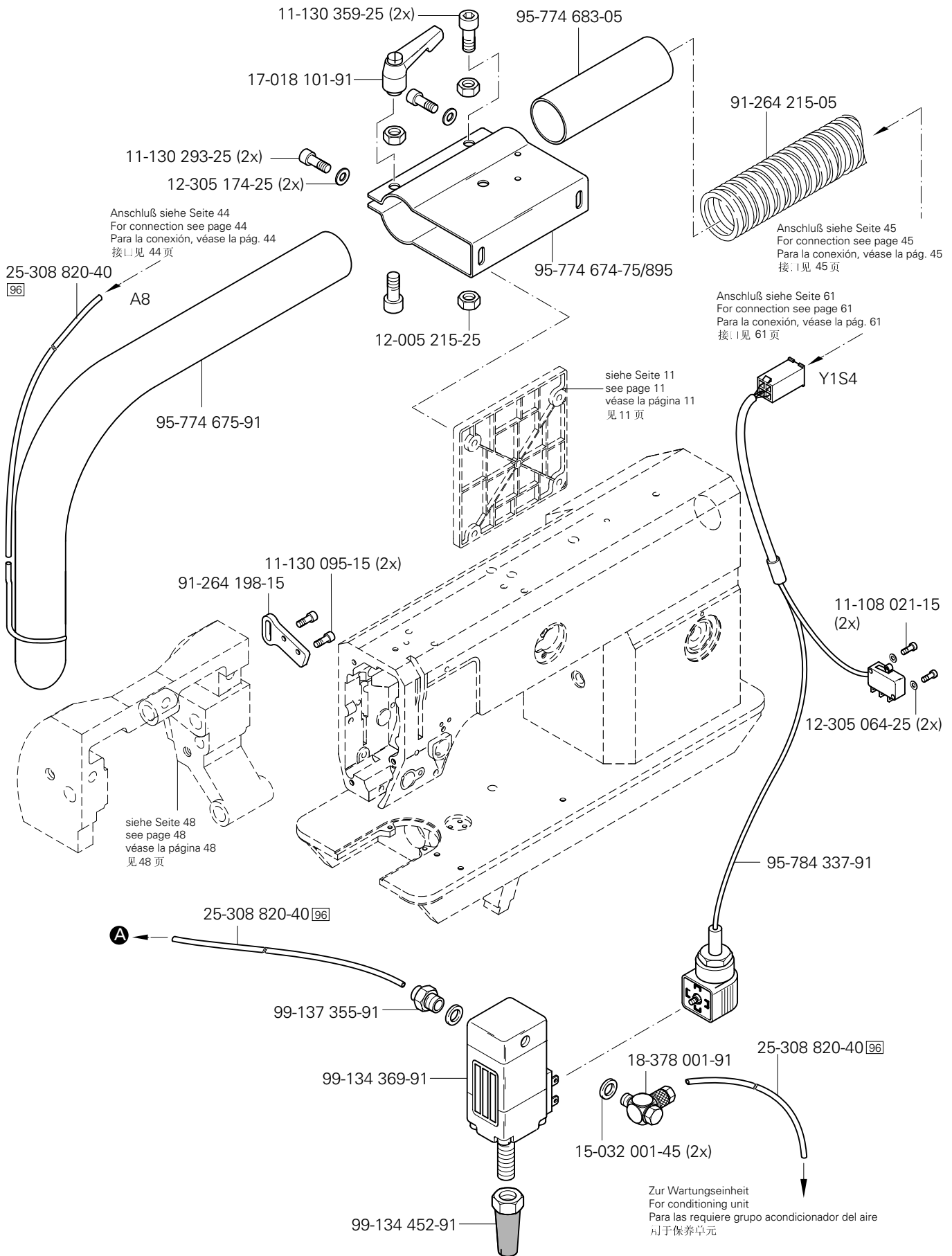
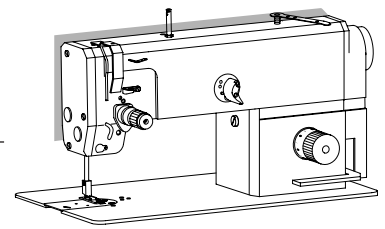

Öl Oil Aceite 油	Mittelpunkts-Viskosität bei: Mean viscosity at: Viscosidad media a: 中点粘度:		Dichte bei: Density of: Densidad a: 密度, 在:		Bestellnummer für Behälter mit: Part number for can with: Número de pedido para recipientes con: 订货号用于油箱, 带:		
	°C	mm ² /s	°C	g/cm ³ (g/ml)	1 Liter 1 Litro 1 升		
28-011 201-44	40	22,0	15	0,865	91-129 917-91		

Fett Grease Grasa 脂	Penetration Penetration Penetración 贯入度	Tropfpunkt Drip-point Punto de goteo 滴点	Bestellnummer für Behälter mit: Part number for can with: Número de pedido para recipientes con: 订货号用于油箱, 带:				
			mm/10	°C	0,25 kg	0,5 kg	1 kg
28-011 202-05							28-011 202-05
28-011 202-47	220-250	185					28-011 202-47

Reinigungsmittel Cleansing agent Limpiadores 清洁剂	Bestellnummer für Behälter mit: Part number for can with: Número de pedido para recipientes con: 订货号用于油箱, 带:		
	240 ml		
Isoprophyl-Alkohol / 异丙醇	95-665 735-91		

No. 零件号	Seite Page Página 页号	No. 零件号	Seite Page Página 页号	No. 零件号	Seite Page Página 页号	No. 零件号	Seite Page Página 页号
11-039 360-15	80	11-130 209-15	44	11-190 176-25	69, 71, 73, 75, 77	11-330 960-15	65
11-039 378-15	54	11-130 224-15	18, 22, 27, 30, 36, 38, 48, 50, 55	11-210 088-25	42	11-330 962-15	24, 37, 52
11-106 104-55	37, 64	11-130 224-25	11, 69, 71, 73, 75, 77	11-210 168-15	23	11-330 964-15	16, 27
11-108 021-15	58, 82	11-130 227-15	20, 39, 49, 59	11-210 216-15	79	11-330 968-15	27
11-108 084-15	33, 51	11-130 227-25	37, 76	11-210 265-15	16	11-335 085-15	33, 51
11-108 084-25	59	11-130 233-15	35, 38, 39, 43, 48	11-225 172-25	11	11-335 169-15	38
11-108 087-15	51	11-130 239-15	39, 42	11-225 178-25	59	11-335 280-15	16, 19, 21, 27
11-108 093-25	42	11-130 251-15	11, 42	11-225 220-15	34	11-341 217-15	22
11-108 096-15	39, 49	11-130 257-25	11	11-225 223-15	13, 31	11-341 277-15	12, 14, 15
11-108 111-15	64	11-130 284-15	24	11-225 226-15	59	11-341 901-15	14
11-108 135-15	38, 48	11-130 287-15	18, 19, 20, 30, 52, 55, 56	11-225 232-15	12, 36, 42, 50	11-341 902-15	27
11-108 171-15	81	11-130 287-25	69, 71, 73, 75, 77	11-225 292-15	58	11-341 904-15	12, 58
11-108 174-15	61, 62	11-130 293-15	11, 55, 56	11-250 084-15	23	11-460 163-15	66
11-108 174-25	12	11-130 293-25	41, 82	11-250 169-15	46	11-460 250-15	66
11-108 177-15	29	11-130 299-25	59	11-317 971-15	14	11-462 307-55	69, 71, 73, 75, 77
11-108 222-15	25, 26, 51	11-130 305-15	60	11-320 171-15	20	11-462 403-55	44, 69
11-108 222-25	11	11-130 305-25	34	11-330 082-15	42	11-470 157-25	45
11-108 306-15	43	11-130 326-25	59	11-330 085-15	13	11-714 031-91	58
11-108 846-15	80	11-130 329-25	59	11-330 166-15	18, 42, 58	12-005 154-15	36, 50
11-108 858-15	58	11-130 359-25	41, 82	11-330 169-15	42	12-005 175-15	19, 20
11-130 086-15	36, 50	11-130 365-15	65	11-330 175-15	23, 50	12-005 195-15	38, 48
11-130 092-25	57	11-132 172-15	12	11-330 205-15	69, 71, 73, 75, 77	12-005 215-15	54, 55, 56, 58
11-130 095-15	82	11-132 223-15	12, 34	11-330 217-15	25, 26, 32, 33, 49, 51	12-005 215-25	41, 82
11-130 167-15	34	11-132 232-15	42	11-330 220-15	12, 13, 14, 15, 31, 38, 48	12-024 121-25	37, 42, 64
11-130 170-25	11, 58, 63	11-170 281-15	17, 40	11-330 232-15	30, 39, 55	12-024 151-25	42, 43, 44
11-130 173-15	11, 38, 39, 48, 49, 52, 58, 64	11-173 168-25	12	11-330 277-15	16, 18, 20, 21, 28, 37, 47, 54, 58	12-024 171-15	30, 55
11-130 176-15	15, 24, 38, 42, 48, 52, 55, 56, 58, 81	11-174 176-15	38, 39, 48, 49	11-330 280-15	16	12-024 171-25	37, 39, 42
11-130 179-15	42, 58	11-174 233-15	80	11-330 952-15	18, 22, 23, 24, 25, 26, 27, 30, 33, 38, 48, 51, 55	12-024 191-15	34, 38, 43, 48, 58
11-130 179-25	76	11-174 912-15	32	11-330 955-15	14, 34, 38, 48, 58, 59	12-024 191-25	23, 42, 57
11-130 185-15	11, 42	11-178 172-15	49	11-330 958-15	37, 47	12-024 210-15	81
11-130 203-15	34, 43	11-178 223-25	20			12-305 064-25	82
		11-180 283-25	11, 38, 48, 68, 70, 72, 74			12-305 084-25	37, 42, 57
						12-305 114-15	15, 42, 43, 44, 52, 58, 64, 81

No. 零件号	Seite Page Página 页号	No. 零件号	Seite Page Página 页号	No. 零件号	Seite Page Página 页号	No. 零件号	Seite Page Página 页号
12-305 144-15	39, 42, 43, 58, 59	12-610 280-45	28	14-012 525-01	52	28-011 202-05	83
12-305 144-25	69, 71, 73, 75, 77	12-618 170-45	11	14-012 903-01	43, 58, 59	28-011 202-47	83
12-305 174-25	41, 59, 68, 69, 70, 71, 72, 73, 74, 75, 77, 82	12-618 190-45	23	14-012 916-01	27	61-111 639-71	79
12-305 264-15	30, 55	12-618 210-45	55, 56	14-016 080-01	25, 26, 33, 51	61-111 639-73	79
12-315 080-15	64	12-624 200-45	36, 50	14-016 101-91	27	61-111 639-76	79
12-325 160-15	58, 59	12-624 210-45	12	14-016 151-91	16	71-120 006-31	64
12-335 171-15	19	12-624 280-45	18	14-016 171-91	27	71-120 006-33	58
12-335 191-15	60	12-624 310-45	28	14-018 624-91	16	71-130 006-39	63
12-341 090-25	22	12-640 090-55	48	14-026 902-01	16	71-170 002-14	54
12-349 901-05	26, 33, 51	12-640 130-55	12, 23, 34, 36, 64	14-218 050-01	42	71-170 002-20	36, 50
12-360 023-05	64	12-640 150-55	17, 20, 40, 52	14-218 906-01	59	71-170 002-21	55, 56
12-360 033-05	52	12-640 170-55	20, 48	14-602 901-01	23	71-170 002-24	52
12-360 043-05	34, 52, 59	12-640 200-55	22, 38, 48	14-731 692-05	42	71-370 001-08	66
12-360 054-05	19, 20	12-650 012-55	21	14-755 037-01	42	71-370 001-31	34
12-360 061-05	27	12-660 390-45	25, 26, 33, 51	15-032 001-45	44, 82	71-370 001-32	64
12-360 063-05	20, 22, 35	12-710 170-15	42	15-032 002-45	60	71-370 001-35	58, 61, 62
12-360 064-05	13, 27, 31	12-710 190-02	52	16-041 045-21	39	71-370 002-92	66
12-360 064-15	42, 58	12-710 210-12	38	16-409 080-05	42	71-520 000-70	42, 58
12-360 083-05	21	12-710 901-22	20	16-409 981-05	59	71-520 006-01	69, 71, 73, 75, 77
12-360 084-05	42	12-710 904-12	30, 55	16-409 983-05	27	71-523 555-76	65
12-360 143-05	18	12-710 913-12	58	16-414 139-05	80	71-590 007-21	69, 71, 73, 75, 77
12-499 150-45	69, 71, 73, 75, 77	13-030 341-05	11, 42	17-018 101-91	41, 82	71-590 007-71	70, 72, 74
12-499 170-45	59	13-030 470-05	45	18-372 001-91	44	71-590 007-72	70, 72, 74, 76
12-499 190-45	52	13-033 190-05	33, 51	18-372 003-91	60	71-590 007-77	70, 72, 74
12-510 140-45	69, 71, 73, 75, 77	13-033 208-05	22	18-372 008-91	44	71-590 007-82	71
12-510 141-15	69, 71, 73, 75, 77	13-033 346-05	79	18-378 001-91	82	71-590 007-83	73
12-610 190-45	17, 18, 24, 34, 40	13-052 085-55	16, 18	25-161 801-49	14, 15, 51	71-590 007-84	67, 70
12-610 200-45	19, 39, 49	13-063 193-05	25, 26, 51	25-161 801-52	14, 15, 26, 33	71-590 007-89	67, 72
12-610 210-45	13, 27, 31, 42	13-064 247-05	12	25-308 820-25	44	71-590 008-32	77
12-610 230-45	25, 26, 30, 33, 42, 51, 55	13-068 391-05	21	25-308 820-40	41, 44, 82	71-590 008-33	67, 76
12-610 250-45	27	13-210 161-05	79	26-536 301-09	14, 15, 26, 33, 51	71-590 008-34	75
		13-250 088-25	14	28-011 201-44	83	71-590 008-35	67, 74
		13-250 097-25	15			71-590 008-42	76

No. 零件号	Seite Page Página 页号	No. 零件号	Seite Page Página 页号	No. 零件号	Seite Page Página 页号	No. 零件号	Seite Page Página 页号
71-590 008-66	69	91-069 484-05	38, 48	91-118 570-92	16	91-174 480-05	32
71-770 000-63	64	91-069 486-05	39, 49	91-118 683-05	23	91-174 507-05	32
71-850 001-48	37	91-069 489-12	39, 49	91-118 711-05	24, 34, 38, 48	91-174 703-91	32
74-064 295-91	68	91-069 490-11	48	91-125 009-05	49	91-174 783-05	23
74-086 502-91	67, 68	91-069 493-11	48	91-129 917-91	83	91-174 851-05	50
91-000 250-15	32	91-069 496-05	48	91-140 945-05	32	91-174 879-05	23, 57
91-000 390-05	32	91-069 498-11	49	91-161 334-25	12	91-174 955-91	32
91-000 621-15	24, 57	91-069 501-15	49	91-162 578-71/698	11	91-174 956-45	32
91-001 824-05	48	91-069 554-12	24	91-162 582-75/895	11	91-175 203-05	28
91-002 134-05	32	91-069 562-05	12	91-162 596-25	12	91-175 265-12	58
91-004 181-05	24, 57	91-069 568-05	12	91-162 690-92	12	91-175 557-11	50
91-009 035-25	23	91-069 577-91	38, 48	91-162 694-05	12	91-175 690-05	32
91-019 929-05	32	91-069 579-05	12, 36	91-162 984-05	12	91-175 785-05	32
91-020 324-05	52	91-069 585-25	23	91-165 685-05	33, 51	91-187 386-15	60
91-027 289-15	80	91-069 598-11	38, 48	91-166 452-21	23	91-187 426-70/893	60
91-027 370-05	80	91-069 599-15	38, 48	91-167 590-15	11	91-188 611-91	45
91-027 371-12	80	91-069 600-15	38, 48	91-168 347-05	28	91-229 070-70/895	78
91-027 645-75/699	79	91-069 601-15	38, 48	91-168 480-15	16	91-229 165-70/893	80
91-029 692-75/792	80	91-069 630-91	38, 48	91-169 457-12	14	91-229 180-90	66
91-056 192-25	23, 50, 57	91-069 632-05	38, 48	91-169 474-05	49	91-229 287-75/699	79
91-056 193-25	23, 50, 57	91-069 709-12	14	91-169 475-15	48	91-232 539-75/895	44
91-056 197-91	50	91-069 789-15	39, 49	91-169 556-05	17, 18, 24	91-262 061-05	27
91-056 198-21	50	91-087 394-15	45	91-171 042-05	23	91-262 161-72/698	16
91-056 578-91	23	91-087 395-15	45	91-171 049-05	23	91-262 162-75/698	11
91-056 760-05	50	91-091 606-91	66	91-171 050-05	12	91-262 164-12	30, 55
91-069 075-11	12	91-100 076-15	57	91-171 068-05	12	91-262 166-91	80
91-069 079-72/895	12	91-100 117-15	12, 36	91-171 409-12	28	91-262 167-05	80
91-069 105-25	12	91-100 270-25	22, 46	91-171 441-01	18	91-262 168-05	80
91-069 322-01	12	91-100 281-25	23	91-171 785-05	33, 51	91-262 174-11	17
91-069 335-72/893	80	91-100 331-15	17	91-171 811-15	17	91-262 179-05	40
91-069 371-92	39, 49	91-100 400-15	16	91-172 676-05	28	91-262 179-15	17
91-069 434-91	12	91-105 482-05	22	91-174 002-05	59	91-262 183-75/895	11
91-069 483-05	38, 48	91-107 265-05	39, 49	91-174 284-01	59	91-262 185-05	51

No. 零件号	Seite Page Página 页号	No. 零件号	Seite Page Página 页号	No. 零件号	Seite Page Página 页号	No. 零件号	Seite Page Página 页号
91-262 187-15	25, 26, 51	91-262 345-12	18	91-262 679-91	55	91-262 857-15	58
91-262 188-15	33, 51	91-262 346-12	18	91-262 680-91	30	91-262 860-92	58
91-262 189-91	51	91-262 347-05	18	91-262 686-91	24	91-262 863-15	59
91-262 195-92	16	91-262 354-05	13, 31	91-262 687-25	24	91-262 865-92	59
91-262 196-05	16	91-262 355-12	22	91-262 688-91	16	91-262 871-05	59
91-262 197-05	22	91-262 357-75/698	81	91-262 689-91	16	91-262 872-91	58
91-262 200-91	22	91-262 360-05	25, 26, 51	91-262 691-90	13	91-262 880-91	56
91-262 201-05	22	91-262 372-92	55, 56	91-262 691-91	13	91-262 882-15	36
91-262 202-15	22	91-262 376-91	26	91-262 692-05	13, 31	91-262 893-91	35
91-262 203-05	22	91-262 377-91	25, 26	91-262 751-90	13	91-262 899-75/896	34
91-262 208-05	33, 51	91-262 385-75/893	69, 71, 73, 75, 77	91-262 751-91	13	91-262 900-05	35
91-262 209-91	51	91-262 408-05	81	91-262 761-71/895	11	91-262 905-91	36
91-262 214-05	25, 26, 51	91-262 409-15	81	91-262 770-05	34	91-262 908-05	35
91-262 218-05	20	91-262 437-05	25, 26	91-262 790-15	36	91-262 916-91	58
91-262 225-91	51	91-262 446-15	54	91-262 791-05	36	91-262 919-05	58
91-262 228-01	29	91-262 447-05	54	91-262 792-05	36	91-262 920-91	58
91-262 231-72/893	21	91-262 457-12	12	91-262 804-91	24	91-262 924-05	58
91-262 232-11	21	91-262 465-15	30, 55, 56	91-262 805-25	24	91-262 926-11	34
91-262 235-15	51	91-262 536-15	11	91-262 806-05	24, 57	91-262 929-15	34
91-262 237-91	26	91-262 544-91	16	91-262 813-91	20	91-262 930-05	34
91-262 250-91	26	91-262 552-12	22	91-262 819-05	15	91-262 931-05	34
91-262 273-05	55, 56	91-262 554-92	18	91-262 821-91	13	91-262 940-91	36
91-262 274-05	21	91-262 565-92	37, 47	91-262 824-96	24	91-262 941-91	12
91-262 277-05	24	91-262 566-05	27	91-262 825-91	24	91-262 958-15	36, 50
91-262 300-91	24	91-262 566-92	27	91-262 836-01	14	91-262 959-71/699	11
91-262 301-12	24	91-262 569-91	50	91-262 837-91	14	91-262 962-91	36
91-262 304-45	13	91-262 573-05	30, 55	91-262 838-91	18	91-262 964-91	12
91-262 320-91	15	91-262 576-05	65	91-262 839-91	18	91-262 983-75/699	58
91-262 326-15	11	91-262 577-75/698	22	91-262 842-92	25, 26, 33, 51	91-262 985-25	11
91-262 329-75/895	11	91-262 578-71/698	22	91-262 843-01	27	91-264 132-75/895	47
91-262 331-91	25, 26	91-262 579-15	55, 56	91-262 844-92	27	91-264 133-75/895	38, 48
91-262 336-91	14	91-262 677-12	30, 55	91-262 845-91	27	91-264 134-91	39, 49
91-262 344-91	18	91-262 678-91	50	91-262 846-05	27	91-264 136-05	48

No. 零件号	Seite Page Página 页号	No. 零件号	Seite Page Página 页号	No. 零件号	Seite Page Página 页号	No. 零件号	Seite Page Página 页号
91-264 139-72/895	49	91-264 240-05	51	91-268 076-15	26, 33, 51	95-774 524-91	57
91-264 140-15	38, 48	91-264 250-05	59	91-280 091-25	79	95-774 525-91	57
91-264 141-91	37, 47	91-264 254-16	24	91-290 113-91	69, 71, 73, 75, 77	95-774 530-91	40
91-264 144-71/895	48	91-264 255-91	28	91-290 337-91	69, 71, 73, 75, 77	95-774 612-92	22
91-264 146-05	38, 48	91-264 258-91	24	91-292 276-91	42, 58	95-774 620-05	33
91-264 147-71/895	49	91-264 259-04/001	28	91-292 300-91	62	95-774 621-91	53
91-264 154-25	24, 43	91-264 293-91	19	91-700 173-15	45	95-774 630-05	59
91-264 156-05	35	91-264 299-91	25	91-700 335-25	11, 47, 53	95-774 646-05	20
91-264 166-01	59	91-264 300-91	25	91-700 785-15	28	95-774 647-05	58
91-264 167-05	59	91-264 301-91	20	91-700 996-15	23	95-774 652-91	31
91-264 170-01	59	91-264 304-05	20	91-701 179-15	24	95-774 656-05	45
91-264 173-01	59	91-264 306-12	20	91-701 346-15	49	95-774 657-05	45
91-264 182-91	37	91-264 310-91	25	91-701 391-15	49	95-774 662-90	31
91-264 183-25	37	91-264 338-15	51	95-665 735-91	83	95-774 663-91	33
91-264 184-25	37	91-264 339-15	17, 40	95-669 358-05	26, 33, 51	95-774 664-91	33
91-264 185-25	37	91-264 340-11	17, 40	95-774 310-91	52	95-774 666-91	33
91-264 186-91	34	91-264 341-91	17	95-774 311-01	52	95-774 667-91	33
91-264 187-91	34	91-264 355-91	20	95-774 313-91	52	95-774 668-15	33
91-264 189-71/896	35	91-264 357-05	23	95-774 314-01	52	95-774 669-12	58
91-264 192-91	64	91-264 358-05	23	95-774 317-05	52	95-774 670-75/895	58
91-264 193-11	64	91-264 364-05	65	95-774 318-01	52	95-774 672-05	58
91-264 196-05	64	91-264 365-91	65	95-774 324-11	52	95-774 673-71/895	58
91-264 197-05	64	91-264 382-70	68, 70, 72, 74	95-774 325-02	27	95-774 674-75/895	41, 82
91-264 198-15	82	91-264 383-91	26	95-774 327-91	11	95-774 675-91	41, 82
91-264 200-75/895	59	91-264 769-92	34	95-774 361-05	57	95-774 678-05	25, 26, 33, 51
91-264 201-71/895	59	91-265 065-05	33, 51	95-774 459-25	57	95-774 679-91	25, 26, 51
91-264 212-91	38, 48	91-265 189-05	24	95-774 460-91	57	95-774 680-75/895	11
91-264 213-12	38, 48	91-265 198-15	17	95-774 464-05	23	95-774 681-91	51
91-264 214-05	38, 48	91-265 227-05	32	95-774 465-25	23	95-774 682-91	26
91-264 215-05	41, 82	91-265 262-91	32	95-774 466-91	23	95-774 683-05	41, 82
91-264 222-15	27	91-265 270-91	32	95-774 467-05	23	95-774 685-15	58
91-264 233-15	11	91-266 397-01	23	95-774 500-75/895	76	95-774 686-91	59
91-264 236-01	59	91-266 856-25	79	95-774 508-91	27	95-774 692-91	46

No. 零件号	Seite Page Página 页号	No. 零件号	Seite Page Página 页号	No. 零件号	Seite Page Página 页号	No. 零件号	Seite Page Página 页号
95-774 693-05	46	99-135 161-85	21				
95-774 694-05	46	99-135 298-91	39, 43				
95-774 696-05	53	99-135 835-05	44				
95-778 312-05	42	99-136 167-91	42				
95-778 313-05	42	99-136 205-91	44				
95-778 314-05	42	99-136 493-91	42				
95-778 315-05	42	99-136 546-91	60				
95-778 316-05	42	99-136 854-55	71, 73, 75, 77				
95-778 317-05	42	99-137 151-45	23				
95-778 318-05	42	99-137 186-05	25, 26				
95-778 319-05	42	99-137 187-15	25, 26				
95-778 321-05	43	99-137 188-15	25, 26				
95-778 322-91	42	99-137 190-05	25, 26				
95-778 327-05	42	99-137 191-05	25, 26				
95-778 328-90	43	99-137 192-05	25, 26				
95-778 329-05	43	99-137 193-05	25, 26				
95-778 330-05	43	99-137 194-05	25, 26				
95-778 331-05	43	99-137 196-05	69, 71, 73, 75, 77				
95-778 333-01	42	99-137 247-45	11				
95-778 335-01	38	99-137 321-91	43				
95-778 338-75/895	39	99-137 341-01	34				
95-778 514-70/895	39	99-137 355-91	82				
95-778 521-71/895	38	99-137 392-91	39				
95-784 321-91	58	99-137 405-15	25				
95-784 333-91	61	99-137 415-05	26				
95-784 337-91	82	99-137 427-05	44				
99-069 722-01	14	99-137 428-91	44				
99-115 505-91	44	99-137 476-91	44				
99-133 220-01	14						
99-134 369-91	82						
99-134 452-91	82						
99-134 544-55	59						
99-134 850-91	42						

PFAFF

1181

1183

Unterklassen-Ausstattung

Subclass parts

Composición de las subclases

子机型-设备

3511

3701

25.01

Nähwerkzeuge[▲]
Gauge parts
Organos de costura
缝纫工具

PFAFF 1181
PFAFF 1181-D
PFAFF 1181-SRP
PFAFF 1181-D-SRP

-8/11

Für allgemeine Näharbeiten.
Standardform des Teilesatzes.
(Zum Nähen mittlerer
Materialien.)

For ordinary sewing operations.
Standard part set.
(for sewing medium-weight
materials.)

Para trabajos de costura en general.
Juego de piezas estándar.
(para coser materiales semiligeros.)

适用于一般性缝纫工作。
套件的标准型式。
(用于中偏厚料的缝纫)

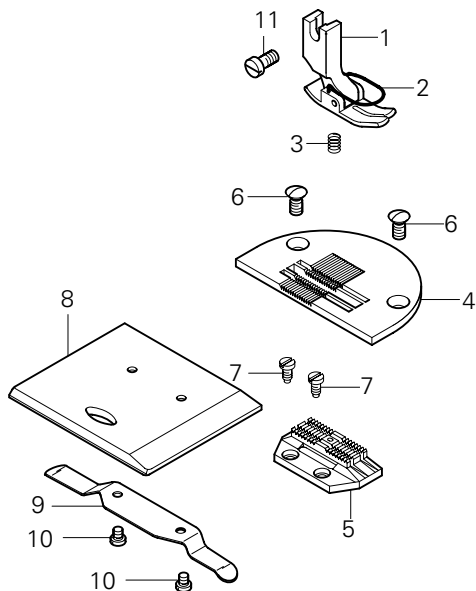

Pos.-Nr. Item No. 序号	Ausführung Model Typo 款式	Stichlänge Stitch length Largo de puntada 针距	Teile-Nr. Part No. 零件号
1 - 10	B♦	4,5	91-202 308-91
1 - 3	B♦	4,5	91-154 804-21
2			91-154 744-05 [3/1]
3			91-154 518-05
4	B♦	4,5	91-150 671-25
5	B♦	4,5	91-059 816-05
6			91-264 154-25
7			91-701 179-15
8 - 10			91-262 686-91
8			91-262 687-25
9			91-004 181-05
10			91-000 621-15
11			11-108 174-15

25.01

Nähwerkzeuge[▲]
Gauge parts
Organos de costura
缝纫工具

PFAFF 1181
PFAFF 1181-G

-8/13

Für allgemeine Näharbeiten.
Standardform des Teilesatzes.
(Zum Nähen mittelschwerer
Materialien.)

For ordinary sewing operations.
Standard part set.
(for sewing medium-heavy
materials.)

Para trabajos de costura en general.
Juego de piezas estándar.
(para coser materiales semipesados.)

适用于一般性缝纫工作。
套件的标准型式。
(用于中偏厚料的缝纫)

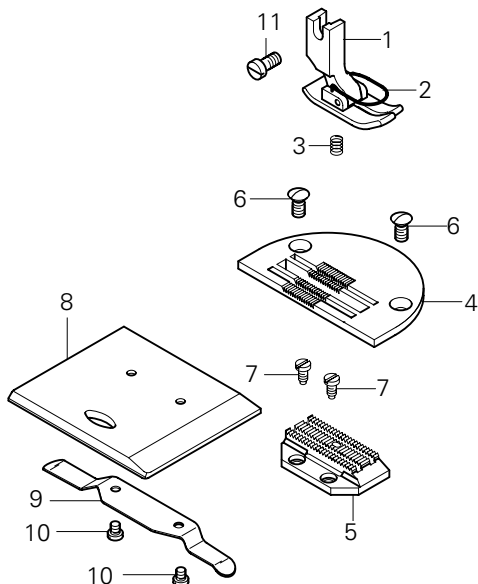

Pos.-Nr. Item No. 序号	Ausführung Model Typo 款式	Stichlänge Stitch length Largo de puntada 针距	Teile-Nr. Part No. 零件号
1 - 10	C♦	6,0	91-202 310-93/001
1 - 3	C♦	6,0	91-154 838-23/001
2			91-154 744-05 [3/1]
3			91-154 518-05
4	C♦	6,0	91-150 672-25
5	C♦	6,0	91-059 961-05
6			91-264 154-25
7			91-701 179-15
8 - 10			91-262 686-91
8			91-262 687-25
9			91-004 181-05
10			91-000 621-15
11			11-108 174-15

-8/92

Für allgemeine Näharbeiten
mittels Brücken-Teilesatz..
(Zum Nähen mittlerer
Materialien.)

For ordinary sewing operations
with bridge-type part set.
(for sewing medium-weight
materials.)

Para trabajos de costura en general
juego de piezas en puente.
(para coser materiales semiligeros.)

适用于借助桥形杆组件的
一般性缝纫工作。
(用于中厚料的缝纫)

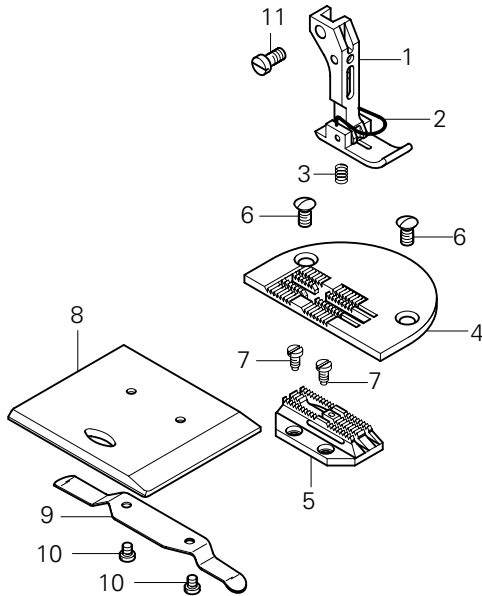

Pos.-Nr. Item No. N° de pos. 序号	Ausführung Model Tipo 款式	Stichlänge Stitch length Largo de puntada 针距	Teile-Nr. Part No. N° de pieza 零件号
1 - 10	B♦	4,5	91-202 453-93/001
1 - 3	B♦	4,5	91-154 832-21
2			91-054 894-05 [3/1]
3			91-154 518-05
4	B♦	4,5	91-150 673-25
5	B♦	4,5	91-059 505-05
6			91-264 154-25
7			91-701 179-15
8 - 10			91-262 686-91
8			91-262 687-25
9			91-004 181-05
10			91-000 621-15
11			11-108 174-15

-34/11

Zum Nähen besonders feiner
Stoffe.

For stitching delicate fabrics.

Para géneros muy finos mediante.

适用于缝纫特薄材料。

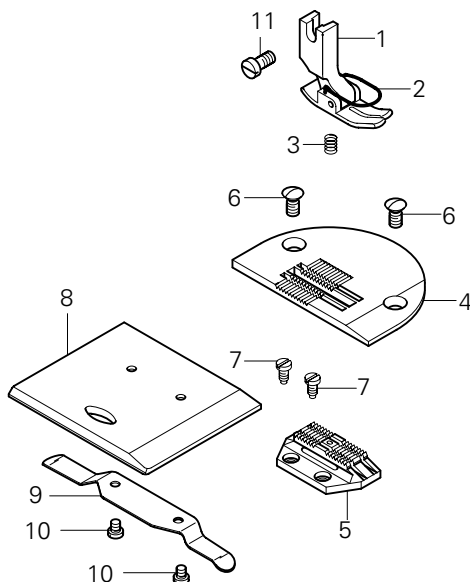

Pos.-Nr. Item No. N° de pos. 序号	Ausführung Model Tipo 款式	Stichlänge Stitch length Largo de puntada 针距	Teile-Nr. Part No. N° de pieza 零件号
1 - 10	A♦	3,0	91-202 450-91
1 - 3	A♦	3,0	91-154 804-21
2			91-154 744-05 [3/1]
3			91-154 518-05
4	A♦	3,0	91-150 819-25
5	A♦	3,0	91-059 496-05
6			91-264 154-25
7			91-701 179-15
8 - 10			91-262 686-91
8			91-262 687-25
9			91-004 181-05
10			91-000 621-15
11			11-108 174-15

25.01 Nähwerkzeuge[▲] Gauge parts Organos de costura 缝纫工具

PFAFF 1181-948/26

-34/92

Zum Nähen besonders feiner
Stoffe mittels Brücken-Teilesatz.

For stitching delicate fabrics
with bridge-type part set.

Para géneros muy finos mediante
juego de piezas en puente.

适用于借助桥形杆组件
缝纫特薄材料。

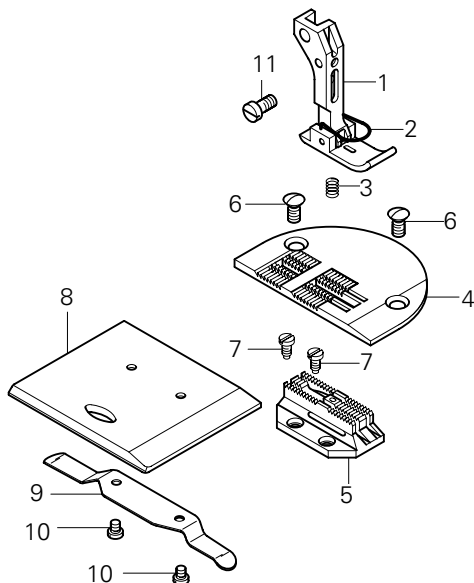

Pos.-Nr. Item No. № de pos. 序号	Ausführung Model Tipo 款式	Stichlänge Stitch length Largo de puntada 针距	Teile-Nr. Part No. № de pieza 零件号
1 - 10	A [◆]	3,0	91-202 454-93/001
1 - 3	A [◆]	3,0	91-154 830-21
2			91-054 894-05 3/1
3			91-154 518-05
4	A [◆]	3,0	91-150 764-25
5	A [◆]	3,0	91-059 504-05
6			91-264 154-25
7			91-701 179-15
8 - 10			91-262 686-91
8			91-262 687-25
9			91-004 181-05
10			91-000 621-15
11			11-108 174-15

25.01 Nähwerkzeuge[▲] Gauge parts Organos de costura 缝纫工具

PFAFF 1181

-731/01-8/11

Arbeitsgang
Operation
Opération
工序

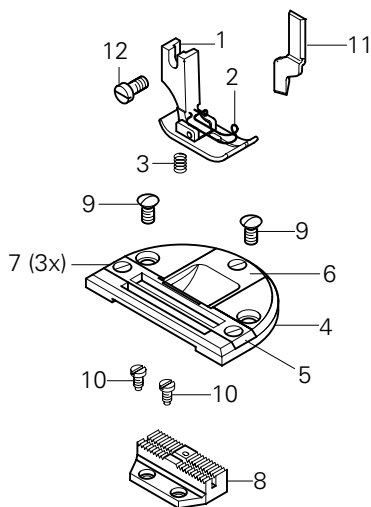
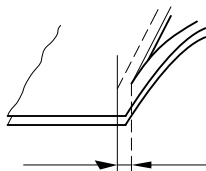

Pos.-Nr. Item No. № de pos. 序号	Ausführung Model Tipo 款式	Stichlänge Stitch length Largo de puntada 针距	Schneidabstand Trimming margin Margen de corte 切边距离	Teile-Nr. Part No. № de pieza 零件号
1 - 11	B [◆]	4,5	4,0	91-202 363-93/003
		4,5	4,5	91-202 363-93/004
		4,5	5,0	91-202 363-93/001
		4,5	6,0	91-202 363-93/005
		4,5	7,0	91-202 363-93/006
		4,5	7,0	91-202 363-93/006
1 - 3	B [◆]	4,5	4,0	91-154 792-03/005
		4,5	4,5	91-154 792-03/006
		4,5	5,0	91-154 792-03/001
		4,5	6,0	91-154 792-03/007
		4,5	7,0	91-154 792-03/008
		4,5	7,0	91-154 792-03/008
2				91-154 797-05 3/1
3				91-154 518-05
4 - 7	B [◆]	4,5	4,0	91-150 676-93/002
		4,5	4,5	91-150 676-93/003
		4,5	5,0	91-150 676-93/001
		4,5	6,0	91-150 676-93/004
		4,5	7,0	91-150 676-93/005
4				91-150 677-05
5	B [◆]	4,5	4,0	91-048 716-03/001
		4,5	4,5	91-048 716-03/002
		4,5	5,0	91-048 716-03/003
		4,5	6,0	91-048 716-03/005
		4,5	7,0	91-048 716-03/007
		4,5	7,0	91-048 716-03/007
6	B [◆]	4,5	4,0	91-048 703-04/004
		4,5	4,5	91-048 703-04/005
		4,5	5,0	91-048 703-04/006
		4,5	6,0	91-048 703-04/008
		4,5	7,0	91-048 703-04/010
		4,5	7,0	91-048 703-04/010
7				91-000 730-25
8	B [◆]	4,5	4,0	91-059 833-04/002
		4,5	4,5	91-059 833-04/004
		4,5	5,0	91-059 833-04/006
		4,5	6,0	91-059 833-04/008
		4,5	7,0	91-059 833-04/010
		4,5	7,0	91-059 833-04/010
9				91-264 154-25
10				91-701 179-15
11				91-169 395-04/002
12				11-108 174-15

-8/31

Für allgemeine Näharbeiten.
Standardform des Teilesatzes.
(Zum Nähen mittlerer
Materialien.)

For ordinary sewing operations.
Standard part set.
(for sewing medium-weight
materials.)

Para trabajos de costura en general.
Juego de piezas estándar.
(para coser materiales semiligeros.)

适用于一般性缝纫工作。
套件的标准型式。
(用于中厚料的缝纫)

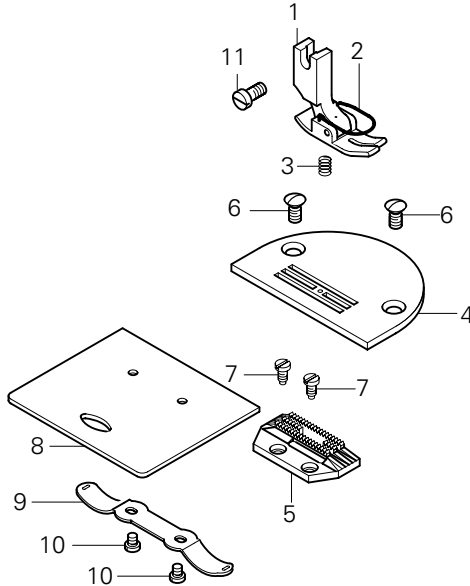

Pos.-Nr. Item No. N° de pos. 序号	Ausführung Model Tipo 款式	Stichlänge Stitch length Largo de puntada 针距	Teile-Nr. Part No. N° de pieza 零件号
1 - 10	B♦	4,5	91-202 356-93/001
1 - 3	B♦	4,5	91-154 807-21
2			91-154 744-05 3/1
3			91-154 518-05
4	B♦	4,5	91-150 694-24/001
5	B♦	4,5	91-059 968-05
6			91-264 154-25
7			91-701 179-15
8 - 10			91-262 804-91
8			91-262 805-25
9			91-262 806-05
10			91-000 621-15
11			11-108 174-15

-8/33

Für allgemeine Näharbeiten.
Standardform des Teilesatzes.
(Zum Nähen mittelschwerer
Materialien.)

For ordinary sewing operations.
Standard part set.
(for sewing medium-heavy
materials.)

Para trabajos de costura en general.
Juego de piezas estándar.
(para coser materiales semipesados.)

适用于一般性缝纫工作。
套件的标准型式。
(用于中偏厚料的缝纫)

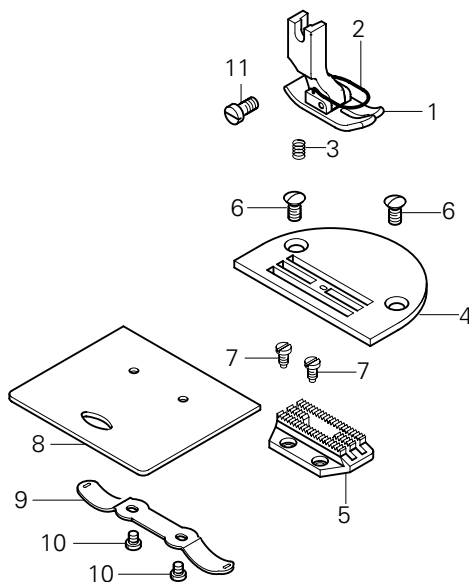

Pos.-Nr. Item No. N° de pos. 序号	Ausführung Model Tipo 款式	Stichlänge Stitch length Largo de puntada 针距	Teile-Nr. Part No. N° de pieza 零件号
1 - 10	C♦	6,0	91-202 357-93/001
1 - 3	C♦	6,0	91-154 845-23/001
2			91-154 744-05 3/1
3			91-154 518-05
4	C♦	6,0	91-150 693-25
5	C♦	6,0	91-059 967-05
6			91-264 154-25
7			91-701 179-15
8 - 10			91-262 804-91
8			91-262 805-25
9			91-262 806-05
10			91-000 621-15
11			11-108 174-15

-8/44

Für Stepparbeiten an Schuh-
schäften und sonstigen
Lederwaren mittels Rollfuß

For sewing loperations on shoe up-
pers and other leather articles; ma-
chine equipped with roller presser.

Para trabajos de aparado en cortes
de calzado y demás artículos de
cuero mediante pie rodante.

适用于滚轮压脚
在鞋帮和其它皮料上的
珩缝针绣工作。

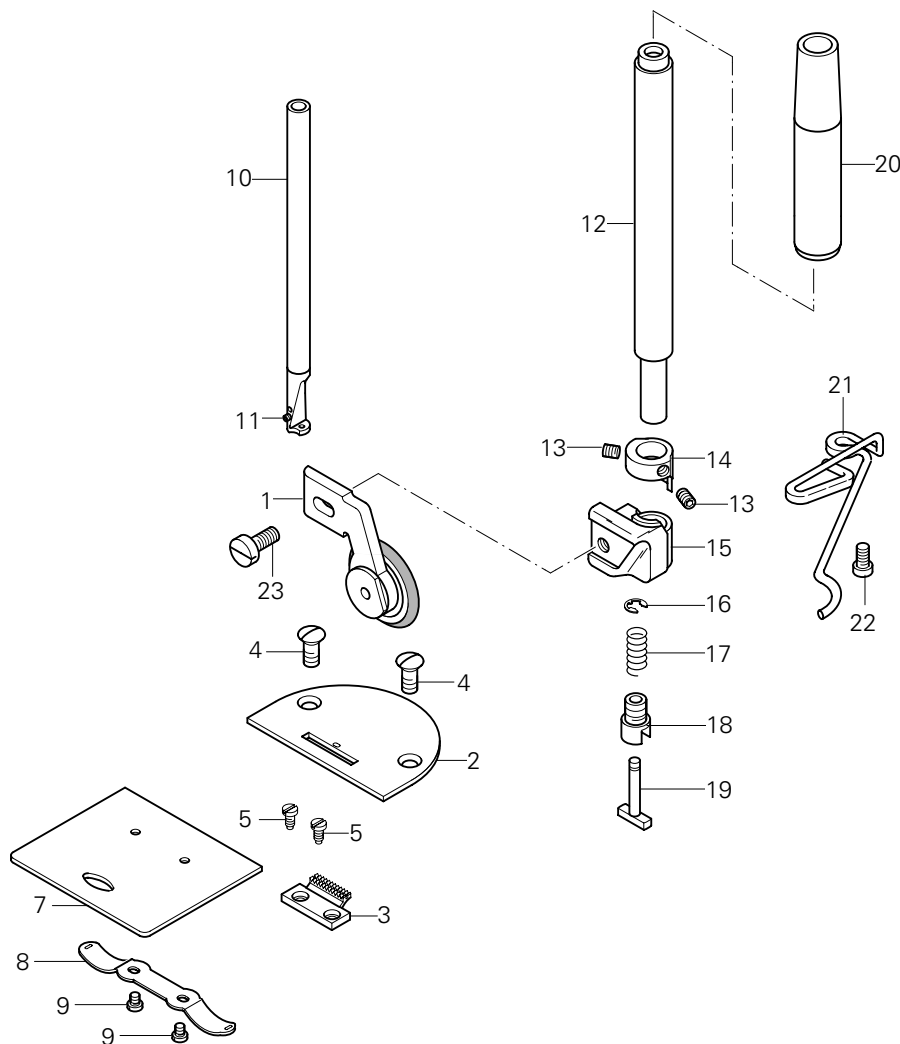

Pos.-Nr. Item No. 序号	Ausführung Model 款式	Stichlänge Stitch length Largo de puntada 针距	Teile-Nr. Part No. 零件号
1 - 9	B♦	4,5	91-202 358-93/002
1	B♦	4,5	91-051 155-93/001
2	B♦	4,5	91-150 695-24/002
3	B♦	4,5	91-059 969-04/002
4			91-264 154-25
5			91-701 179-15
6 - 9			91-262 804-91
7			91-262 805-25
8			91-262 806-05
9			91-000 621-15
10 - 11			91-262 565-92
11			11-330 958-15

Pos.-Nr. Item No. 序号	Ausführung Model 款式	Stichlänge Stitch length Largo de puntada 针距	Teile-Nr. Part No. 零件号
12 - 20			91-171 075-91
12			91-171 076-01
13			91-700 388-15
14			91-169 322-15
15			91-169 323-15
16			12-640 070-55
17			91-025 376-05
18			91-700 409-15
19			91-025 374-05
20			91-171 557-05
21			91-262 520-25
22			11-132 172-15
23			91-700 717-15

-8/93

Für allgemeine Näharbeiten.
Standardform des Teilesatzes.
(Zum Nähen mittlerer
Materialien.)

For ordinary sewing operations.
Standard part set.
(for sewing medium-weight
materials.)

Para trabajos de costura en general.
Juego de piezas estándar.
(para coser materiales semiligeros.)

适用于借助桥形杆组件的
一般性缝纫工作。
(用于中厚料的缝纫)

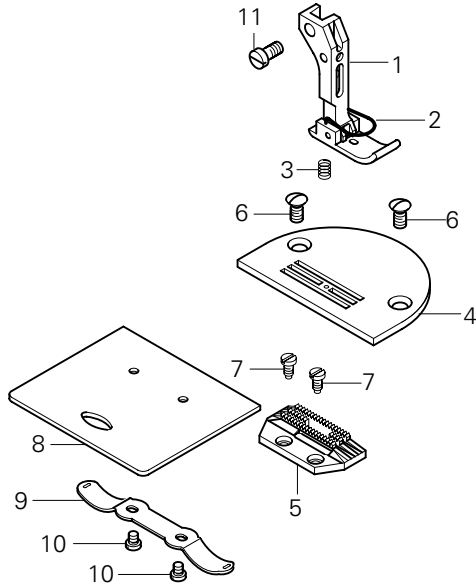

Pos.-Nr. Item No. 序号	Ausführung Model Typo 款式	Stichlänge Stitch length Largo de puntada 针距	Teile-Nr. Part No. 零件号
1 - 10	B♦	4,5	91-202 391-93/001
1 - 3	B♦	4,5	91-154 834-23/002
2			91-054 894-05 [3/1]
3			91-154 518-05
4	B♦	4,5	91-150 694-24/001
5	B♦	4,5	91-059 968-05
6			91-264 154-25
7			91-701 179-15
8 - 10			91-262 804-91
8			91-262 805-25
9			91-262 806-05
10			91-000 621-15
11			11-108 174-15

-34/31

Zum Nähen besonders feiner
Stoffe.

For stitching delicate fabrics.

Para géneros muy finos mediante.

适用于缝纫特薄材料。

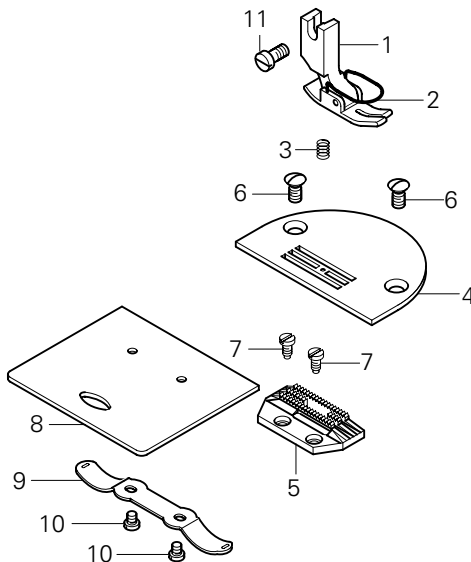

Pos.-Nr. Item No. 序号	Ausführung Model Typo 款式	Stichlänge Stitch length Largo de puntada 针距	Teile-Nr. Part No. 零件号
1 - 10	A♦	3,0	91-202 448-93/001
1 - 3	A♦	3,0	91-154 843-23/001
2			91-154 744-05 [3/1]
3			91-154 518-05
4	A♦	3,0	91-150 820-25
5	A♦	3,0	91-059 497-05
6			91-264 154-25
7			91-701 179-15
8 - 10			91-262 804-91
8			91-262 805-25
9			91-262 806-05
10			91-000 621-15
11			11-108 174-15

25.02 Nähwerkzeuge[▲] Gauge parts Organos de costura 缝纫工具

PFAFF 1183-948/26

-34/93

Zum Nähen besonders feiner Stoffe.

For stitching delicate fabrics.

Para géneros muy finos mediante.

适用于缝纫特薄材料。

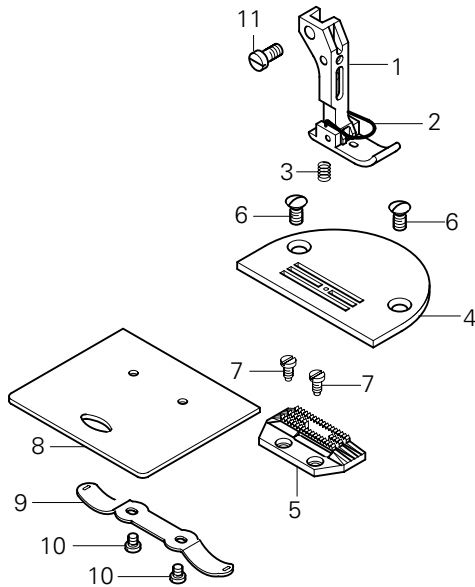

Pos.-Nr. Item No. 序号	Ausführung Model Typo 款式	Stichlänge Stitch length Largo de puntada 针距	Teile-Nr. Part No. 零件号
1 - 10	A [◆]	3,0	91-202 449-93/001
1 - 3	A [◆]	3,0	91-154 834-23/001
2			91-054 894-05 3/1
3			91-154 518-05
4	A [◆]	3,0	91-150 820-25
5	A [◆]	3,0	91-059 497-05
6			91-264 154-25
7			91-701 179-15
8 - 10			91-262 804-91
8			91-262 805-25
9			91-262 806-05
10			91-000 621-15
11			11-108 174-15

25.02 Nähwerkzeuge[▲] Gauge parts Organos de costura 缝纫工具

PFAFF 1183
PFAFF 1183- D

-731/01-8/31

Arbeitsgang
Operation
Opéracion
工序

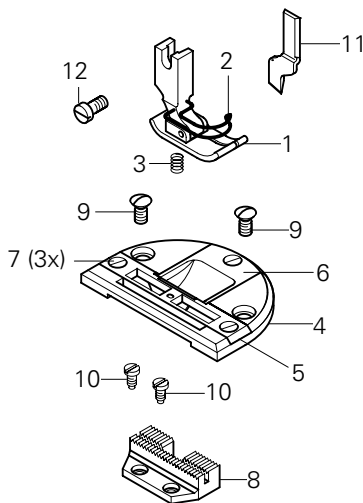
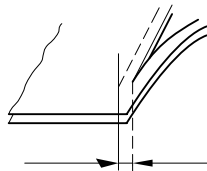

Pos.-Nr. Item No. 序号	Ausführung Model Typo 款式	Stichlänge Stitch length Largo de puntada 针距	Schneidabstand Trimming margin Margen de corte 切边距离	Teile-Nr. Part No. 零件号
1 - 11	B [◆]	4,5	5,0	91-202 364-93/001
	B [◆]	4,5	7,0	91-202 364-93/002
1 - 3	B [◆]	4,5	4,0	91-154 794-03/005
	B [◆]	4,5	4,5	91-154 794-03/006
	B [◆]	4,5	5,0	91-154 794-03/001
	B [◆]	4,5	6,0	91-154 794-03/007
	B [◆]	4,5	7,0	91-154 794-03/008
2				91-154 797-05 3/1
3				91-154 518-05
4 - 7	B [◆]	4,5	5,0	91-150 680-93/001
	B [◆]	4,5	7,0	91-150 680-93/002
4				91-150 677-05
5	B [◆]	4,5	4,0	91-048 705-03/012
	B [◆]	4,5	4,5	91-048 705-03/013
	B [◆]	4,5	5,0	91-048 705-03/014
	B [◆]	4,5	6,0	91-048 705-03/016
	B [◆]	4,5	7,0	91-048 705-03/025
6	B [◆]	4,5	4,0	91-048 703-04/004
	B [◆]	4,5	4,5	91-048 703-04/005
	B [◆]	4,5	5,0	91-048 703-04/006
	B [◆]	4,5	6,0	91-048 703-04/008
	B [◆]	4,5	7,0	91-048 703-04/010
7				91-000 730-25
8	B [◆]	4,5	4,0	91-047 464-04/009
	B [◆]	4,5	4,5	91-047 464-04/010
	B [◆]	4,5	5,0	91-047 464-04/011
	B [◆]	4,5	6,0	91-047 464-04/012
	B [◆]	4,5	7,0	91-047 464-04/013
9				91-264 154-25
10				91-701 179-15
11				91-169 395-04/002
12				11-108 174-15

-2/01

Arbeitsgang
 Operation
 Operación
 工序

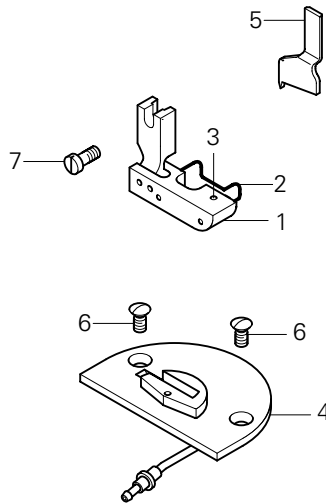
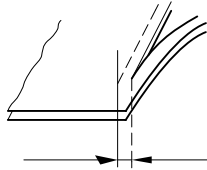

Pos.-Nr. Item No. N° de pos. 序号	Ausführung Model Tipo 款式	Stichlänge Stitch length Largo de puntada 针距	Schneidabstand Trimming margin Margen de corte 切边距离	Teile-Nr. Part No. N° de pieza 零件号
1 - 5	B [◆] B [◆]	3,5 4,5	5,0 5,0	91-202 770-93/001 [28] 91-202 770-93/002
1 - 3	B [◆]	4,5	5,0	91-154 921-91
2				91-154 924-05
3				11-317 086-15
4	B [◆] B [◆]	3,5 4,5	5,0 5,0	91-150 890-03/001 [28] 91-150 890-03/002
5				91-165 629-05
6				91-264 154-25
7				11-108 174-15

-4/11

Ist ein gestalteter Arbeitsplatz zum Bundnähen im Nahtschatten bzw. zum Bunddurchsteppen.

Is an engineered workplace for sink-stitching or top-stitching waistbands.

Es una estación de trabajo diseñada para pespuntear pretinas con "puntas invisibles", o bien sobrecoser pretinas.

用于在接缝处缝裤腰接缝及裤腰衍缝的缝纫工位

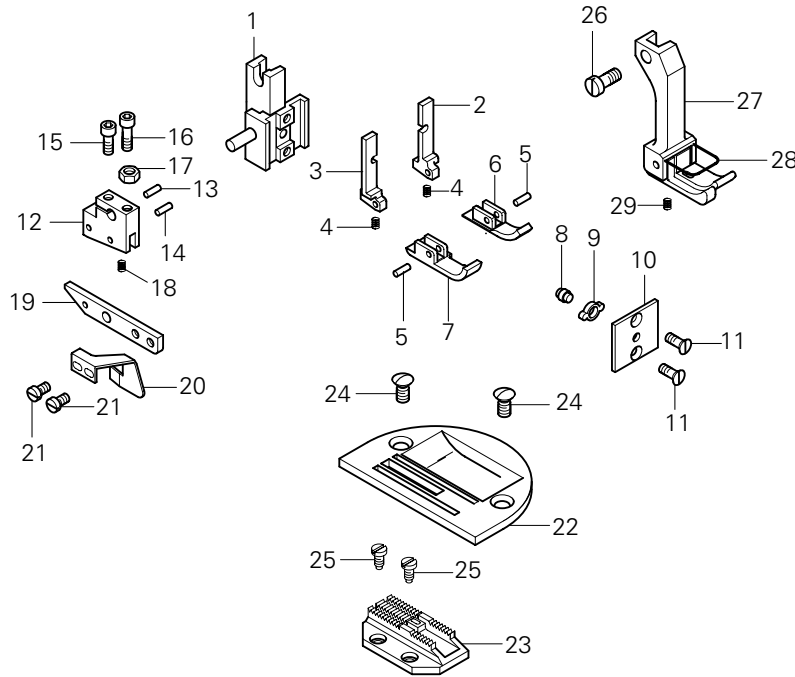

Pos.-Nr. Item No. N° de pos. 序号	Teile-Nr. Part No. N° de pieza 零件号
1 - 23	91-202 762-91
1 - 21	91-154 910-91 90/110
1	91-154 911-01
2	91-154 913-05
3	91-154 912-05
4	91-010 099-05
5	21-302 302-08 35/1 96
6	91-154 916-05
7	91-154 915-05
8	91-057 441-05
9	91-057 442-05
10	91-154 914-05
11	11-210 041-15
12 - 21	91-154 917-91
12	91-154 918-05
13	13 052 088-05

Pos.-Nr. Item No. N° de pos. 序号	Teile-Nr. Part No. N° de pieza 零件号
14	13-052 088-55
15	11-130 095-15
16	11-130 097-15
17	12-005 125-15
18	91-010 099-05
19	91-154 919-05
20	91-154 920-05
21	11-172 085-25
22	91-150 835-25
23	91-059 415-05
24	91-264 154-25
25	91-701 179-15
26	11-108 174-15
27 - 29	91-154 931-93/003 90/111
28	91-154 864-04/001 3/1
29	91-154 852-05

PFAFF

PFAFF Industrie Maschinen AG

Postfach 3020
D-67653 Kaiserslautern

Königstr. 154
D-67655 Kaiserslautern

Telefon: (0631) 200-0
Telefax: (0631) 17202
E-Mail: info@pfaff-industrial.com