

EXT Special Parts 専用部品

EXT3200 Series 差動上下送り安全縫いマシン
Variable top feed safety stitch machines

EXT5200 Series 差動上下送りオーバーロックマシン
Variable top feed overedgers

Parts Catalog

NUOVA VERSIONE



PEGASUS®

パーツカタログの見方

- このパーツカタログは、2003年8月製造中のEXTシリーズのミシンを次の要領で編集しています。
※専用部品以外の部品は、EX3200・5200シリーズと同じ部品を使用しています。EXシリーズパーツブックをご覧ください。(Cat. No. 96050)
- 2～47頁には部品を機構別に収録し、左頁が部品の分解図、右頁がパーツリストになっています。また、部品分解図に付されている番号は、パーツリストのREF.NO. (参照番号) を示しています。
- パーツリストの部品番号の表記がXXXXXXの部品は、特定の形式(サブクラス)にのみ使用されているゲージパーツ部品で、形式によって変わります。形式ごとの部品番号はゲージパーツ表(48～55頁)に一括して記載しています。
- 巻末には部品番号インデックスを記載し、部品番号だけで、その図解・名称などが容易に引き出せます。
- 部品を御注文いただく時は、部品番号を明示してください。なお、このパーツカタログの記載事項は改良により、予告なく変更されることがありますので、あらかじめご了承ください。

INTRODUCTION

- This parts catalog covers the EXT series machine manufactured in August, 2003.
※ Since common parts are used between the EX3200・5200 series and EXT3200・5200 series, refer to the EX3200・5200 series parts book(Cat. No. 96050) for parts except special ones.
- The components of EXT Series are arranged according to the mechanism on pages 2-47. The illustrations are on left pages and the part numbers on right pages. The illustrated part and its part number are assigned the same reference number.
- "XXXXXX" indicates gauge part numbers which vary depending on subclasses. Please refer to the gauge part list (pages 48-55).
- The index of part numbers are listed at the back of this book for quick reference.
- To place an order for any part, please specify the part number. Note that the contents of this book are subject to change for improvement without prior notice.

掲載機種 (Models inserted)

EXT3200 Series

EXT3215(16)-02/223(K)	EXT3216H-45P1/574K
EXT3215(16)-03/233(K)	EXT3215(16)-C3P1/233(K)
EXT3216-03/333(K)	EXT3215(16)-C3P2/333(K)
EXT3244-03/333(K)	EXT3216H-C5P1/574K
EXT3215(16)-03/433(K)	
EXT3215(16)-A04/435K	
EXT3244-A04/435K	
EXT3215(16)-B-04/435(K)	
EXT3215(16)H-A05/535K	
EXT3215(16)-42/233(K)	

EXT5200 Series

EXT5204-02/233(K)	EXT5214-84/433(K)
EXT5214-03/333(K)	EXT5214H-85/535K
EXT5214-M03/333(K)	EXT5214-C3P1/333(K)
EXT5205-12/223(K)	EXT5214-C3P2/333(K)
EXT5214-43/333(K)	
EXT5214-54S1/433(K)	
EXT5214-54S2/433(K)	
EXT5214-54S1/443(K)	
EXT5214-54S2/443(K)	
EXT5214H-55/545(K)	

目次

	頁
上送り機構 (1)	2 ~ 3
上送り機構 (2)	4 ~ 5
上送り機構 (3)	6 ~ 7
カバー機構	8 ~ 9
糸道・糸繰り関係	10 ~ 11
針振り機構	12 ~ 13
押工機構	14 ~ 15
給油機構 (1)	16 ~ 17
給油機構 (2)	18 ~ 19
専用部品 (1) EXT3215(16)-02.03, EXT3244-03, EXT5204-02, EXT5214-03, M03,	20 ~ 21
専用部品 (2) EXT3215(16)-A04, EXT3215(16)H-A05	22 ~ 23
専用部品 (3) EXT3244-A04	24 ~ 25
専用部品 (4) EXT3215(16)-B-04	26 ~ 27
専用部品 (5) EXT5205-12	28 ~ 29
専用部品 (6) EXT3215(16)-42, EXT5214-43, 54S2	30 ~ 31
専用部品 (7) EXT3215(16)-42, EXT3216H-45P1, C5P1, EXT5214-43	32 ~ 33
専用部品 (8) EXT3216H-45P1, C5P1	34 ~ 35
専用部品 (9) EXT3216H-45P1, C5P1	36 ~ 37
専用部品 (10) EXT3215(16)-C3P1, C3P2, EXT5214-C3P1, C3P2 ...	38 ~ 39
専用部品 (11) EXT5214-43, 54S1, 54S2, 84, EXT5214H-55	40 ~ 41
専用部品 (12) EXT5214H-55	42 ~ 43
専用部品 (13) EXT5214-84, EXT5214H-85	44 ~ 45
当定規	46 ~ 47
ゲージパーツ表	48 ~ 55
糸通シ図一覧	56
インデックス	57 ~ 58

TABLE OF CONTENTS

	page
TOP FEED MECHANISM(1)	2 ~ 3
TOP FEED MECHANISM(2)	4 ~ 5
TOP FEED MECHANISM(3)	6 ~ 7
COVER	8 ~ 9
THREAD GUIDE & THREAD TAKE-UP	10 ~ 11
NEEDLE DRIVE MECHANISM	12 ~ 13
PRESSER FOOT MECHANISM	14 ~ 15
LUBRICATION MECHANISM(1)	16 ~ 17
LUBRICATION MECHANISM(2)	18 ~ 19
SPECIFIC PARTS(1) EXT3215(16)-02.03, EXT3244-03, EXT5204-02, EXT5214-03, M03	20 ~ 21
SPECIFIC PARTS(2) EXT3215(16)-A04, EXT3215(16)H-A05	22 ~ 23
SPECIFIC PARTS(3) EXT5244-A04	24 ~ 25
SPECIFIC PARTS(4) EXT3215(16)-B-04	26 ~ 27
SPECIFIC PARTS(5) EXT5205-12	28 ~ 29
SPECIFIC PARTS(6) EXT3215(16)-42, EXT5214-43, 54S2 ...	30 ~ 31
SPECIFIC PARTS(7) EXT3215(16)-42, EXT3216H-45P1, C5P1, EXT5214-43	32 ~ 33
SPECIFIC PARTS(8) EXT3216H-45P1, C5P1	34 ~ 35
SPECIFIC PARTS(9) EXT3216H-45P1, C5P1	36 ~ 37
SEPCIFIC PARTS(10) EXT3215(16)-C3P1, C3P2, EXT5214-C3P1, C3P2	38 ~ 39
SPECIFIC PARTS(11) EXT5214-43, 54S1, 54S2, EXT5214H-55	40 ~ 41
SPECIFIC PARTS(12) EXT5214H-55	42 ~ 43
SPECIFIC PARTS(13) EXT5214-84, EXT5214H-85	44 ~ 45
FABRIC EDGE GUIDE	46 ~ 47
GAUGE PARTS LIST	48 ~ 55
THREADING DIAGRAM	56
INDEX	57 ~ 58

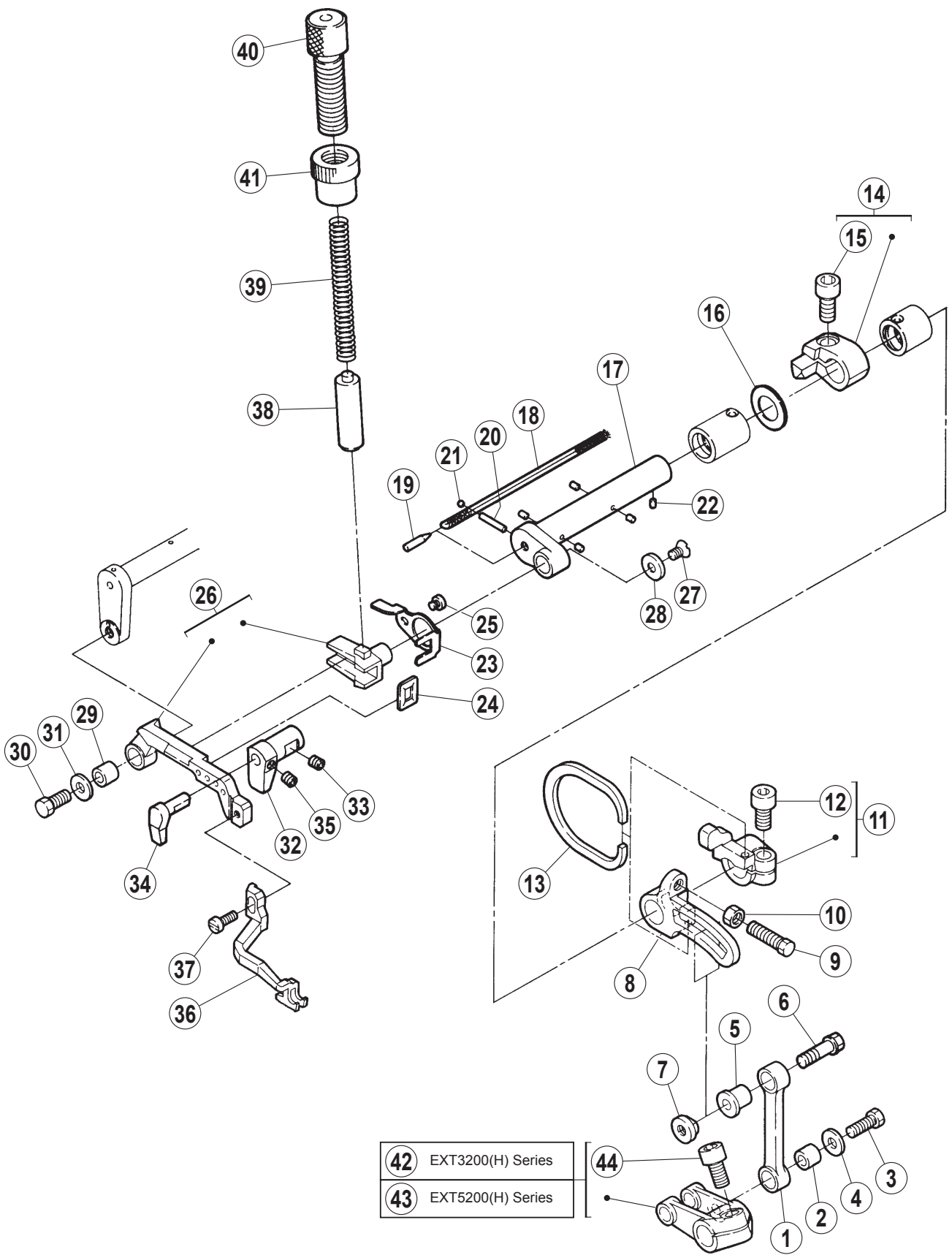

上送り機構 (1)

TOP FEED MECHANISM(1)

REF.NO.	PART NO.	部品名称	DESCRIPTION	QT.
1	2765340	リンク	LINK	1
2	2405420	ブッシュ	BUSHING	1
3	0070560	六角ボルト /M5X13	BOLT	1
4	2400390	座金	WASHER	1
5	2765350	ブッシュ	BUSHING	1
6	0072330	六角ボルト /M5X17	BOLT	1
7	2765260	ナット	NUT	1
8	2765330	クランク	CRANK	1
9	0072060	六角ボルト /M6X22	BOLT	1
10	0072070	六角ナット /M6	NUT	1
11	276536-920	カラー	COLLAR	1
12	0045330	六角穴ボルト /M6X12	BOLT	1
13	2765380	板バネ	FLAT SPRING	1
14	276520-920	カラー	COLLAR	1
15	0045340	六角穴ボルト /M6X14	BOLT	1
16	2082350	座金	WASHER	1
17	2765270	クランク軸	CRANKSHAFT	1
18	2021760	給油紐	OIL WICK	1
19	2403680	ピン	PIN	1
20	179320-050	フェルト	FELT	1
21	2401480	球	BALL	1
22	2073580	フェルト	FELT	5
23	2765400	油切り案内	GUIDE/FEED BAR OIL SEAL	1
24	2765390	油切り	OIL SEAL	1
25	0070070	平小ネジ /M3X3	SCREW	1
26	276528-910	上送り台 (組)	TOP FEED BAR ASSY.	1
27	0070440	皿小ネジ /M4X10	SCREW	1
28	2402940	座金	WASHER	1
29	2405420	ブッシュ	BUSHING	1
30	0070560	六角ボルト /M5X13	BOLT	1
31	2400390	座金	WASHER	1
32	2765310	上送り台案内	GUIDE/TOP FEED BAR	1
33	0045430	六角穴止ネジ /M4X4	SCREW	1
34	2765320	上送り台案内	GUIDE/TOP FEED BAR	1
35	0045430	六角穴止ネジ /M4X4	SCREW	1
36	XXXXXX	上送り歯	TOP FEED DOG	1
37	0070140	平小ネジ /M3.5X10	SCREW	1
38	2740350	押工棒	PRESSER BAR	1
39	2402910	圧縮バネ	SPRING	1
40	2740360	調節ネジ	SCREW	1
41	2740370	ナット	NUT	1
42	273002A920	クランク	CRANK	1
43	273001A920	クランク	CRANK	1
44	0045330	六角穴ボルト /M6X12	BOLT	1

● xxxxxx はゲージパーツです。
部品番号は 48 ~ 55 頁のゲージパーツ表を
参照してください。

● "xxxxxx" represents the gauge part.
Please refer to the gauge part list (page48-55).

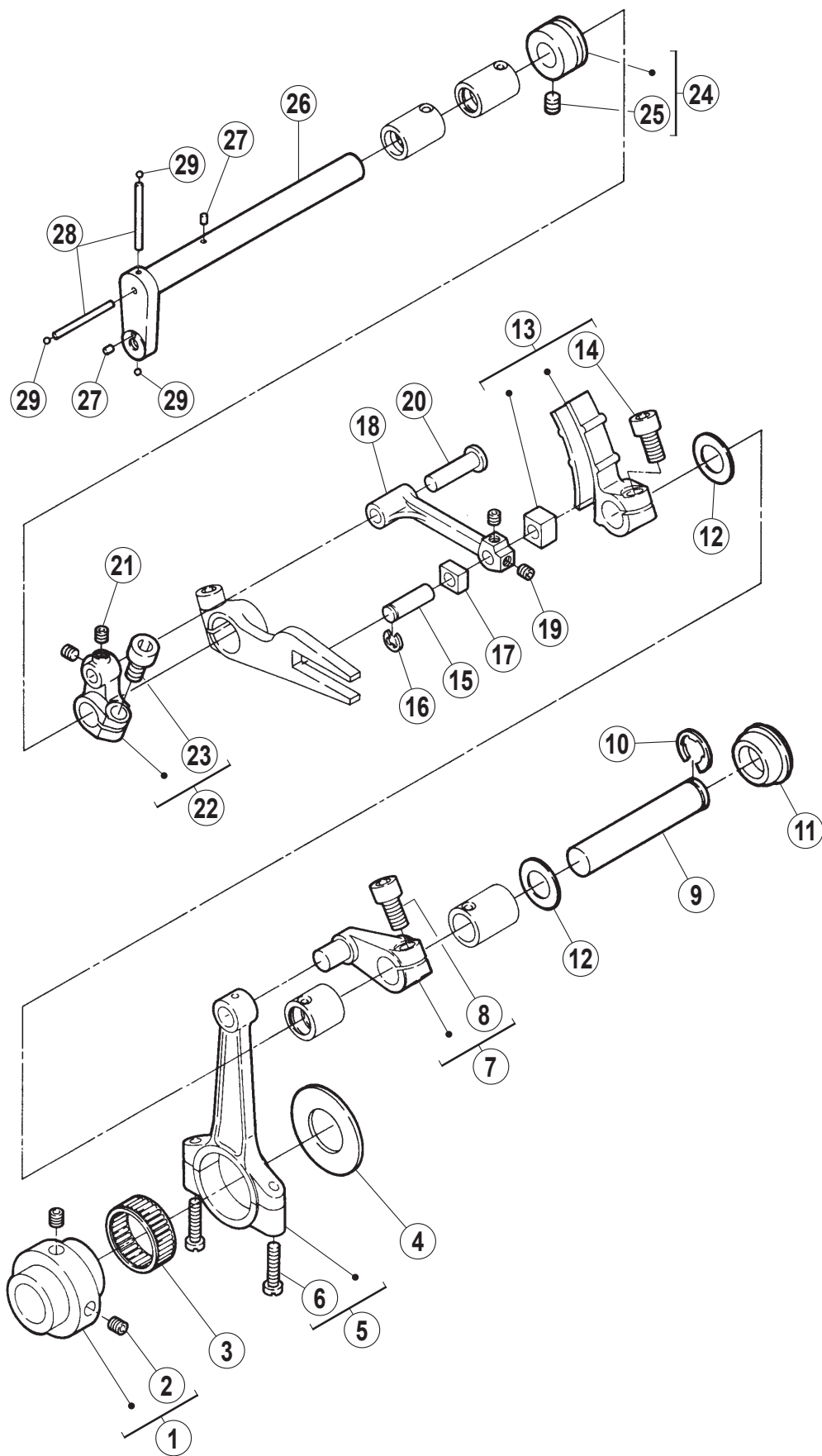

上送り機構 (2)

TOP FEED MECHANISM(2)

REF.NO.	PART NO.	部品名称	DESCRIPTION	QT.
1	276500-920	エキセン	ECCENTRIC	1
2	0045140	六角穴止ネジ /M5X5	SCREW	2
3	240298-20	ニードルベアリング	NEEDLE PIN	1
4	2402970	座金	WASHER	1
5	276501A920	ロッド	CONNECTION	1
6	007024A0	十字穴ナベ小ネジ /M4X18	SCREW	2
7	276502-920	クランク	CRANK	1
8	0045330	六角穴ボルト /M6X12	BOLT	1
9	271003B0	軸	SHAFT	1
10	2025770	止メ輪	RETAINING RING	1
11	2401100	栓	PLUG	1
12	2082350	座金	WASHER	2
13	276504-910	クランク (組)	CRANK ASSY.	1
14	0045330	六角穴ボルト /M6X12	BOLT	1
15	2765070	平行ピン	PIN	1
16	2016290	止メ輪	RETAINING RING	1
17	2765080	角駒	BLOCK	1
18	2765090	リンク	LINK	2
19	0045430	六角穴止ネジ /M4X4	SCREW	1
20	2765100	ピン	PIN	1
21	0045430	六角穴止ネジ /M4X4	SCREW	2
22	276511-920	クランク	CRANK	1
23	0045330	六角穴ボルト /M6X12	BOLT	1
24	276537-920	カラー	COLLAR	1
25	0045140	六角穴止ネジ /M5X5	SCREW	1
26	2765120	クランク軸	CRANKSHAFT	1
27	2073580	フェルト	FELT	2
28	2403510	フェルト	FELT	2
29	2401480	球	BALL	3

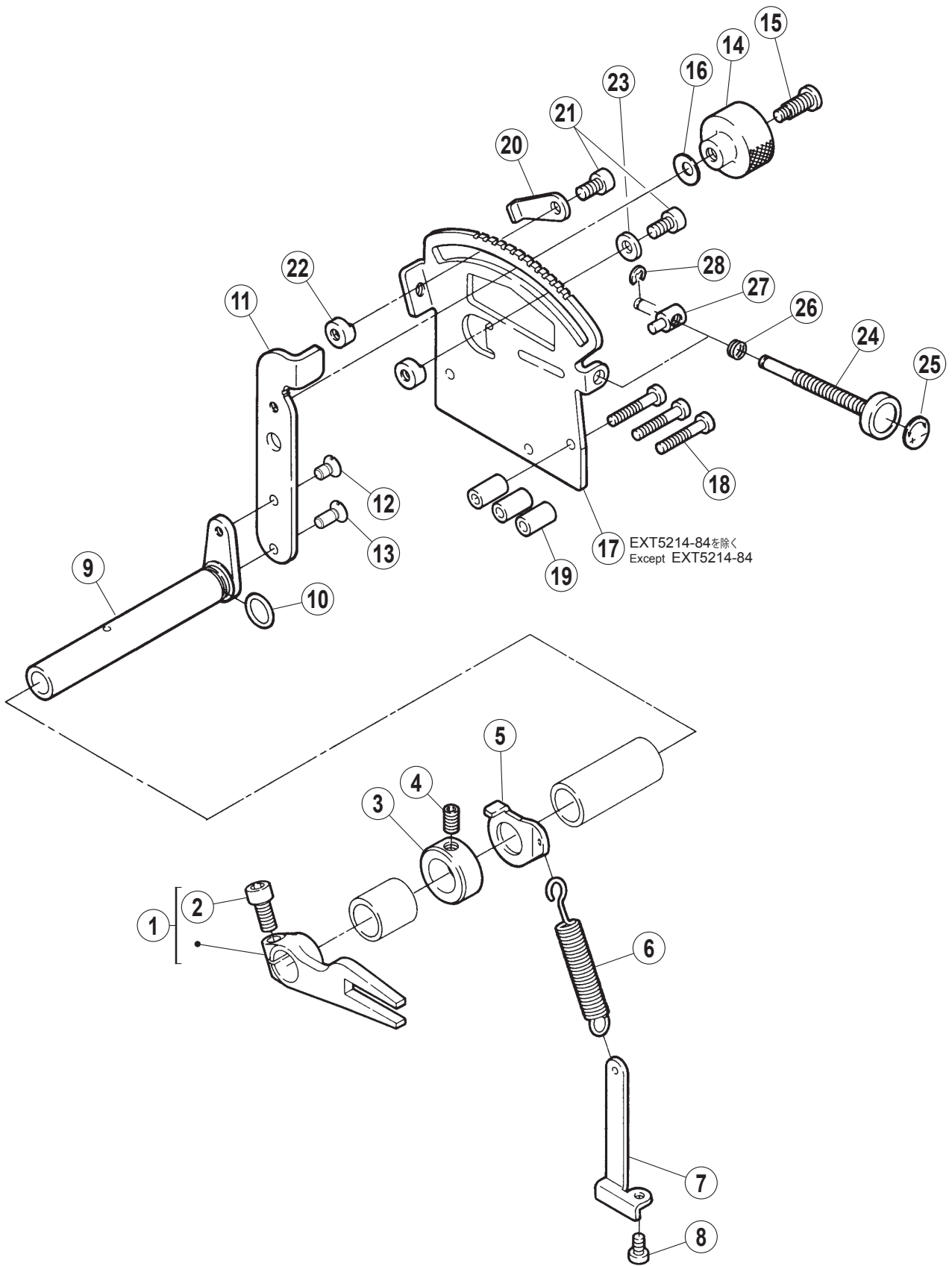

上送り機構 (3)

TOP FEED MECHANISM(3)

REF.NO.	PART NO.	部品名称	DESCRIPTION	QT.
1	276513-920	レバー	LEVER	1
2	0045340	六角穴ボルト /M6X14	BOLT	1
3	2402960	カラー	COLLAR	1
4	0045210	六角穴止ネジ /M6X10	SCREW	1
5	2765150	ラッチ	LATCH	1
6	2765030	引張りバネ	SPRING	1
7	2765160	ラッチ	LATCH	1
8	007019A0	十字穴ナベ小ネジ /M4X8	SCREW	1
9	2765140	軸	SHAFT	1
10	2010220	Oリング	O RING	1
11	2765170	レバー	LEVER	1
12	0070770	皿小ネジ /M4X7	SCREW	1
13	0070440	皿小ネジ /M4X10	SCREW	1
14	2765190	ナット	NUT	1
15	0070590	段ネジ /M4.5	SCREW	1
16	2113010	皿バネ	SPRING	1
17	2765180	調節板	BLADE GUIDE	1
18	0070260	平小ネジ /M4X25	SCREW	3
19	2403320	スペーサー	SPACER	3
20	2765240	ストッパー	STOPPER	1
21	0045000	六角穴ボルト /M5X10	BOLT	2
22	179201-150	ナット	NUT	2
23	2400420	座金	WASHER	1
24	272538A0	調節棒	ASJUSTING BAR	1
25	2403220	シール	SEAL	1
26	2405590	圧縮バネ	SPRING	1
27	272539A0	段付ピン	PIN	1
28	2005550	止メ輪	RETAINING RING	1

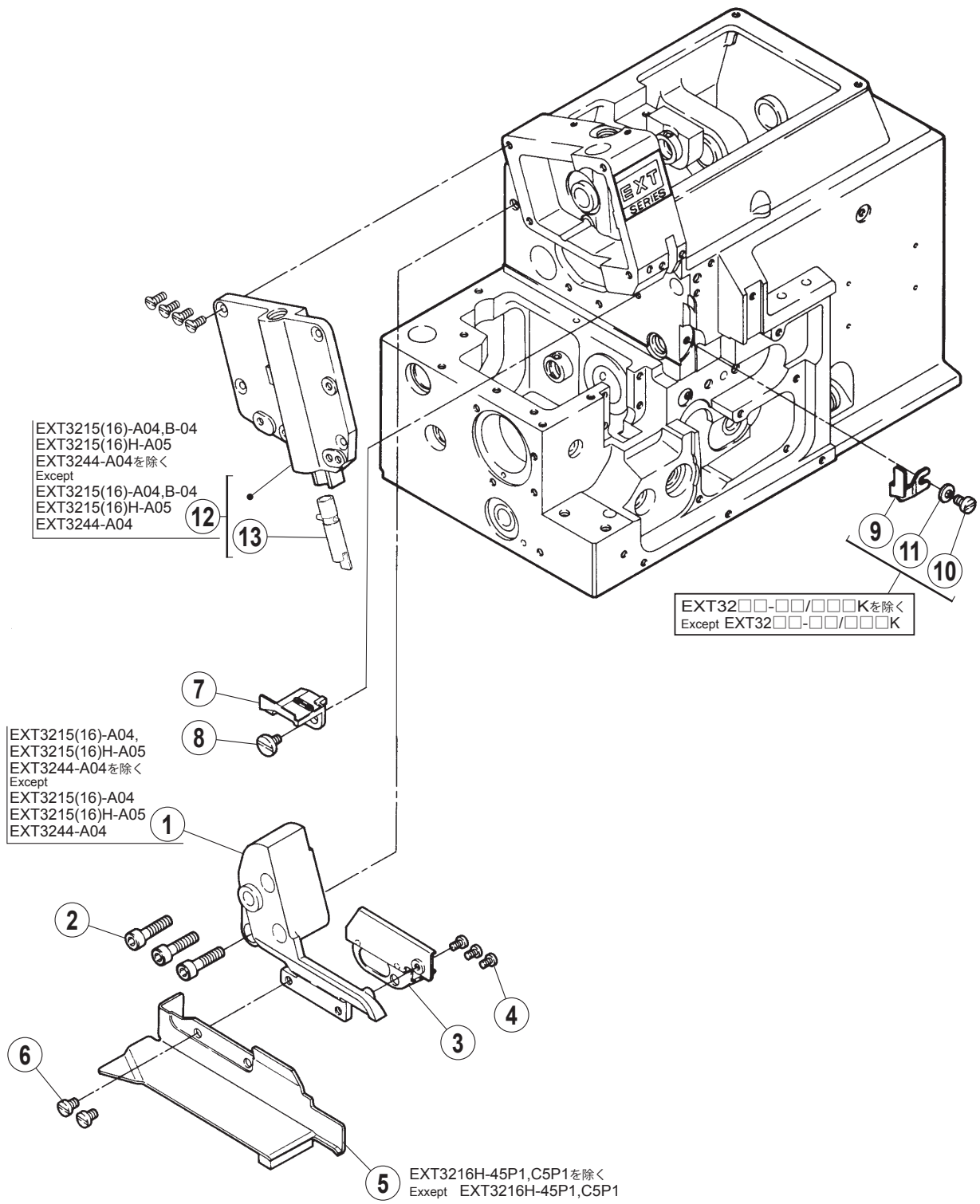

カバー機構

COVER

REF.NO.	PART NO.	部品名称	DESCRIPTION	QT.
1	2700680	ブラケット	BRACKET	1
2	0045110	六角穴ボルト /M6X25	BOLT	3
3	2700670	カバー	COVER	1
4	0071540	平小ネジ /M3X3.5	SCREW	3
5	270069-911	布案内	FABRIC GUARD	1
6	0073550	ナベ小ネジ /M4.5X6	SCREW	2
7	2700790	カバー	COVER	1
8	0070660	段ネジ /M4	SCREW	1
9	2700810	カバー	COVER	1
10	0071430	ナベ小ネジ /M4X5.5	SCREW	1
11	2109300	皿バネ	SPRING	1
12	270083A9U0	側面カバー (組)	SIDE COVER ASSY.	1
13	274011-910	押し棒	PRESSER BAR	1

EXT5200(H)Series

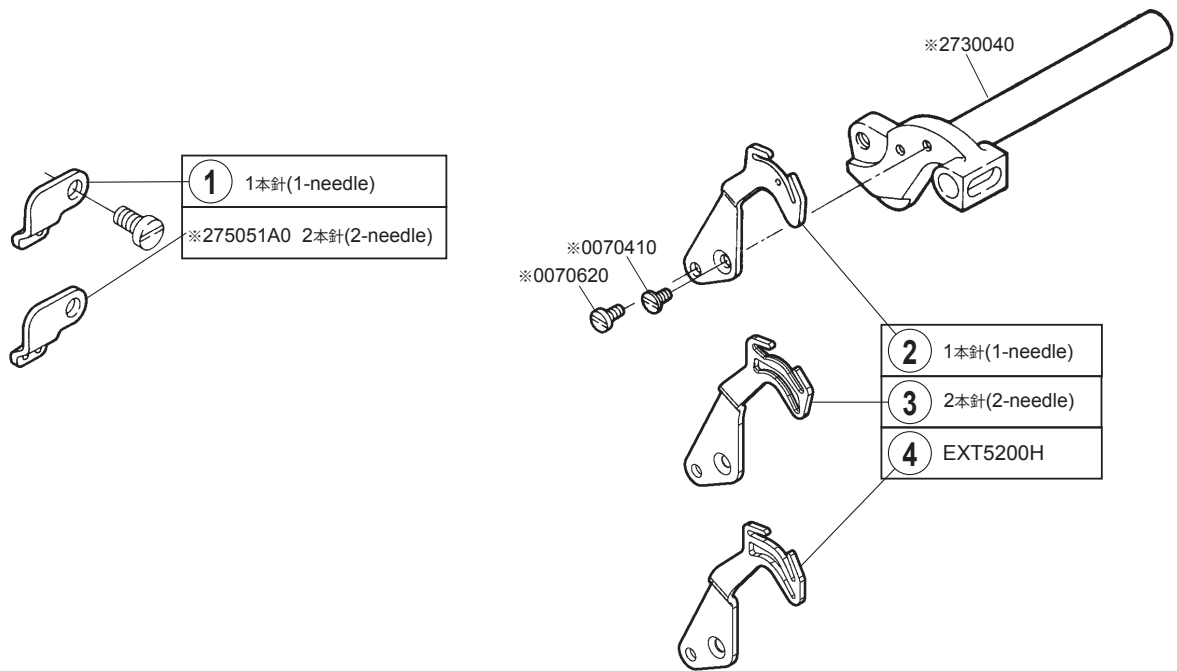

EXT3200(H)Series

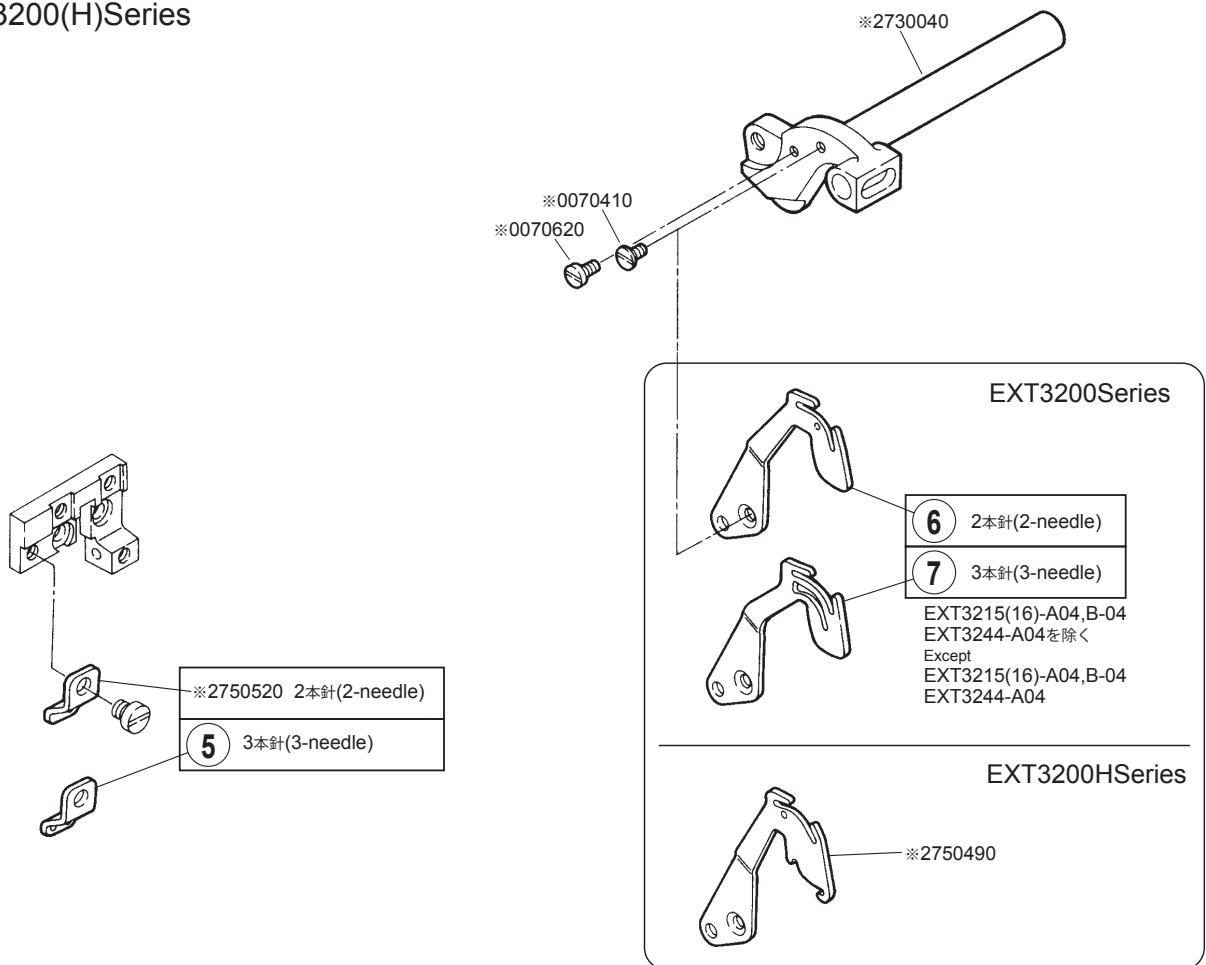

※印は、EX3200H・EX5200Hと共通使用部品です。
Marked ※ parts are the common ones between
EX3200H・EX5200H and EXT series

糸道・糸繰り関係

THREAD GUIDE & THREAD TAKE-UP

REF.NO.	PART NO.	部品名称	DESCRIPTION	QT.
1	2750510	糸道	THREAD GUIDE	1
2	275016A0	針糸繰り	NEEDLE THREAD TAKE-UP	1
3	275106A0	針糸繰り	NEEDLE THREAD TAKE-UP	1
4	275017A0	針糸繰り	NEEDLE THREAD TAKE-UP	1
5	275052A0	糸道	THREAD GUIDE	1
6	275027A0	針糸繰り	NEEDLE THREAD TAKE-UP	1
7	275044A0	針糸繰り	NEEDLE THREAD TAKE-UP	1

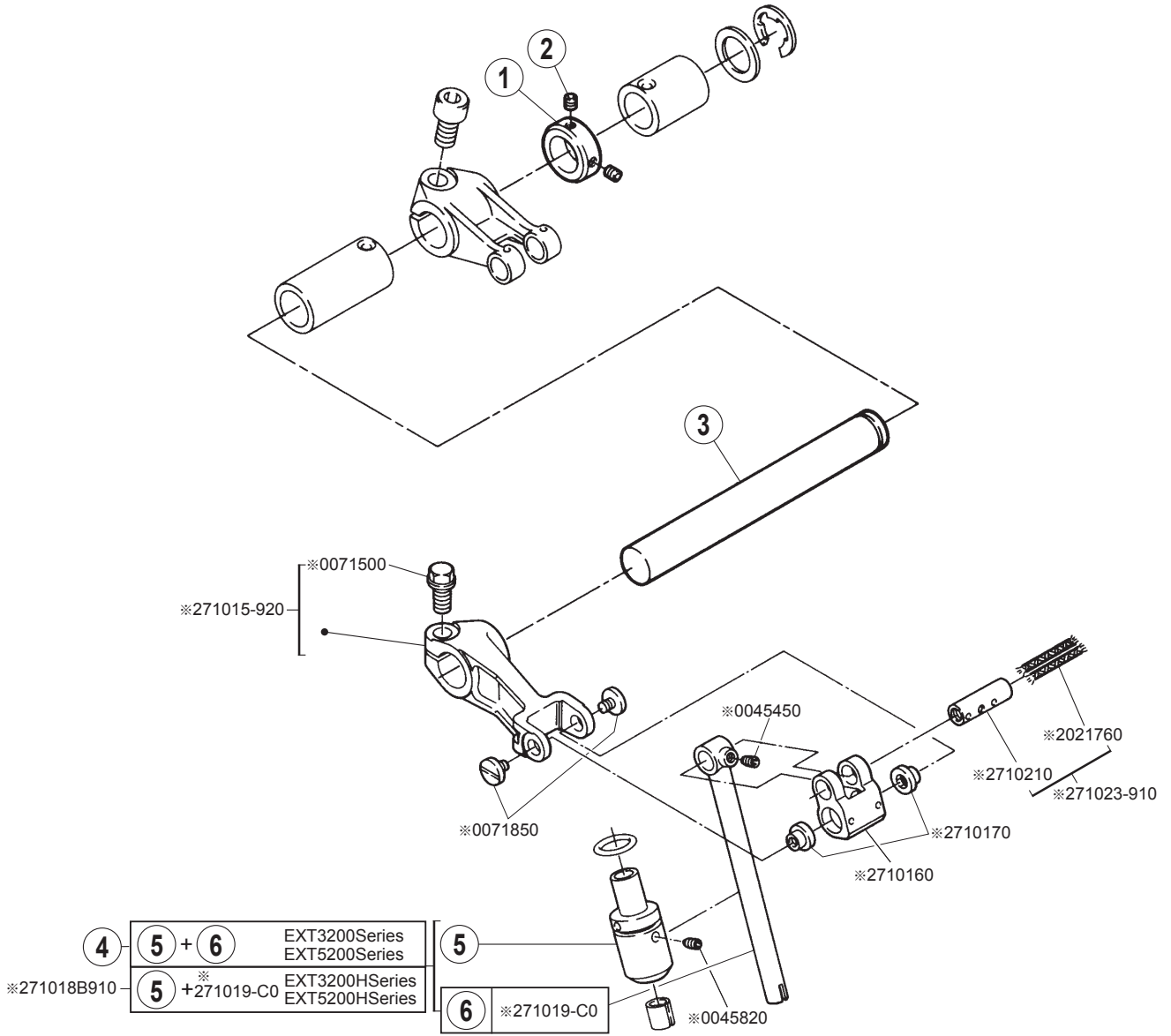

※印は、EX3200H・EX5200Hと共通使用部品です。
 Marked ※ parts are the common ones between
 EX3200H・EX5200H and EXT series

針振り機構

NEEDLE DRIVE MECHANISM

REF.NO.	PART NO.	部品名称	DESCRIPTION	QT.
1	2402920	カラー	COLLAR	1
2	0045540	六角穴止ネジ /M3X3	SCREW	2
3	271003A0	軸	SHAFT	1
4	271018C910	ブッシュ (組)	BUSHING ASSY.	1
5	2710200	ブッシュ	BUSHING	1
6	271019AC0	針棒	NEEDLE BAR	1

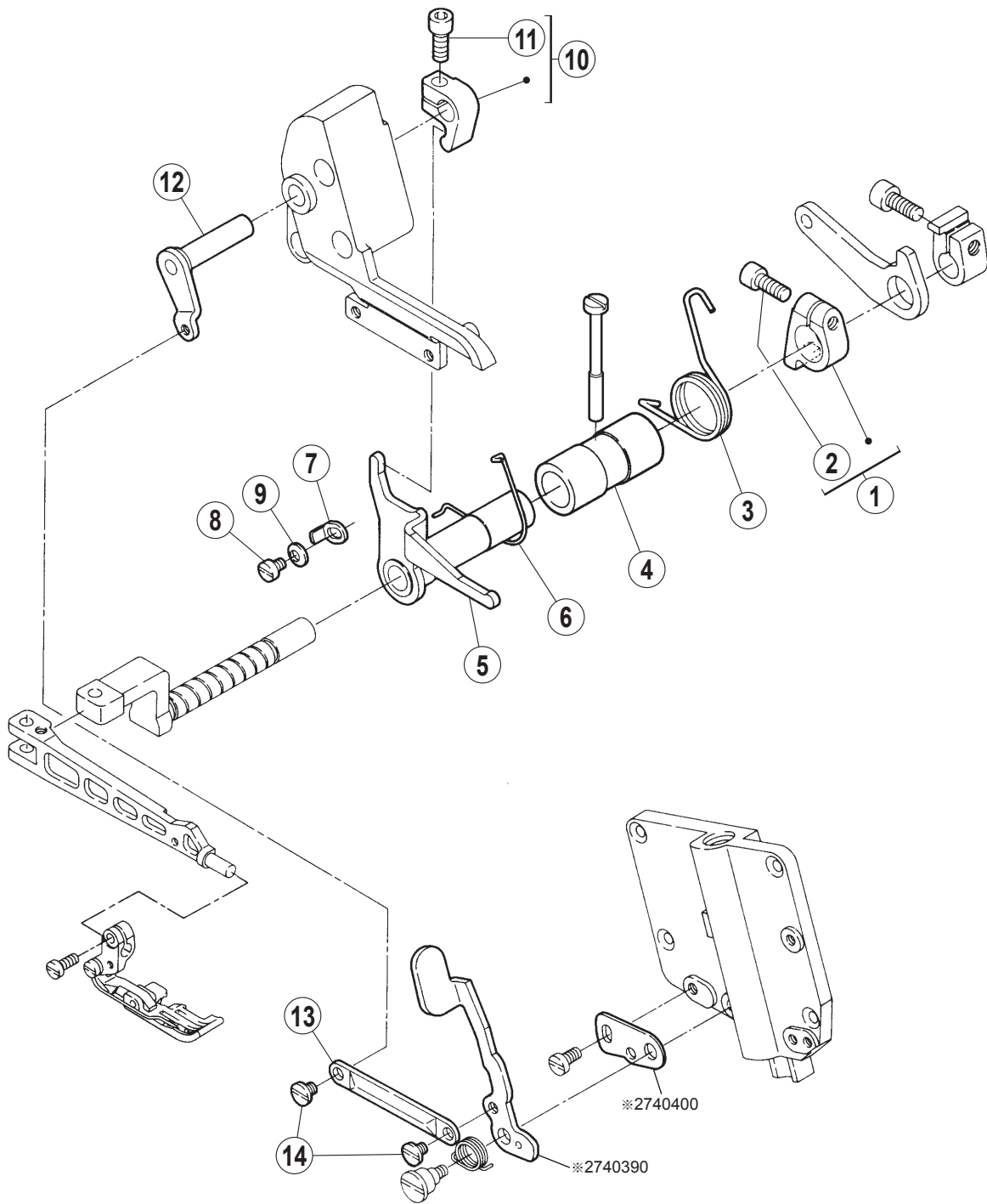

※印は、EX3200H・EX5200Hと共通使用部品です。
 Marked ※ parts are the common ones between
 EX3200H・EX5200H and EXT series

押工機構

PRESSER FOOT MECHANISM

REF.NO.	PART NO.	部品名称	DESCRIPTION	QT.
1	274042-920	カラー	COLLAR	1
2	0045010	六角穴ボルト /M5X14	BOLT	1
3	2740430	ネジリバネ	SPRING	1
4	2740440	ブッシュ	BUSHING	1
5	274045-910	レバー	LEVER	1
6	2740550	線細工バネ	SPRING	1
7	2740540	ストッパー	STOPPER	1
8	0070180	平小ネジ /M4X6	SCREW	1
9	2109300	皿バネ	SPRING	1
10	213218A920	レバー	LEVER	1
11	0045310	六角穴ボルト /M5X12	BOLT	1
12	274048-910	レバー	LEVER	1
13	2740410	リンク	LINK	1
14	0071931	段ネジ /M4	SCREW	2

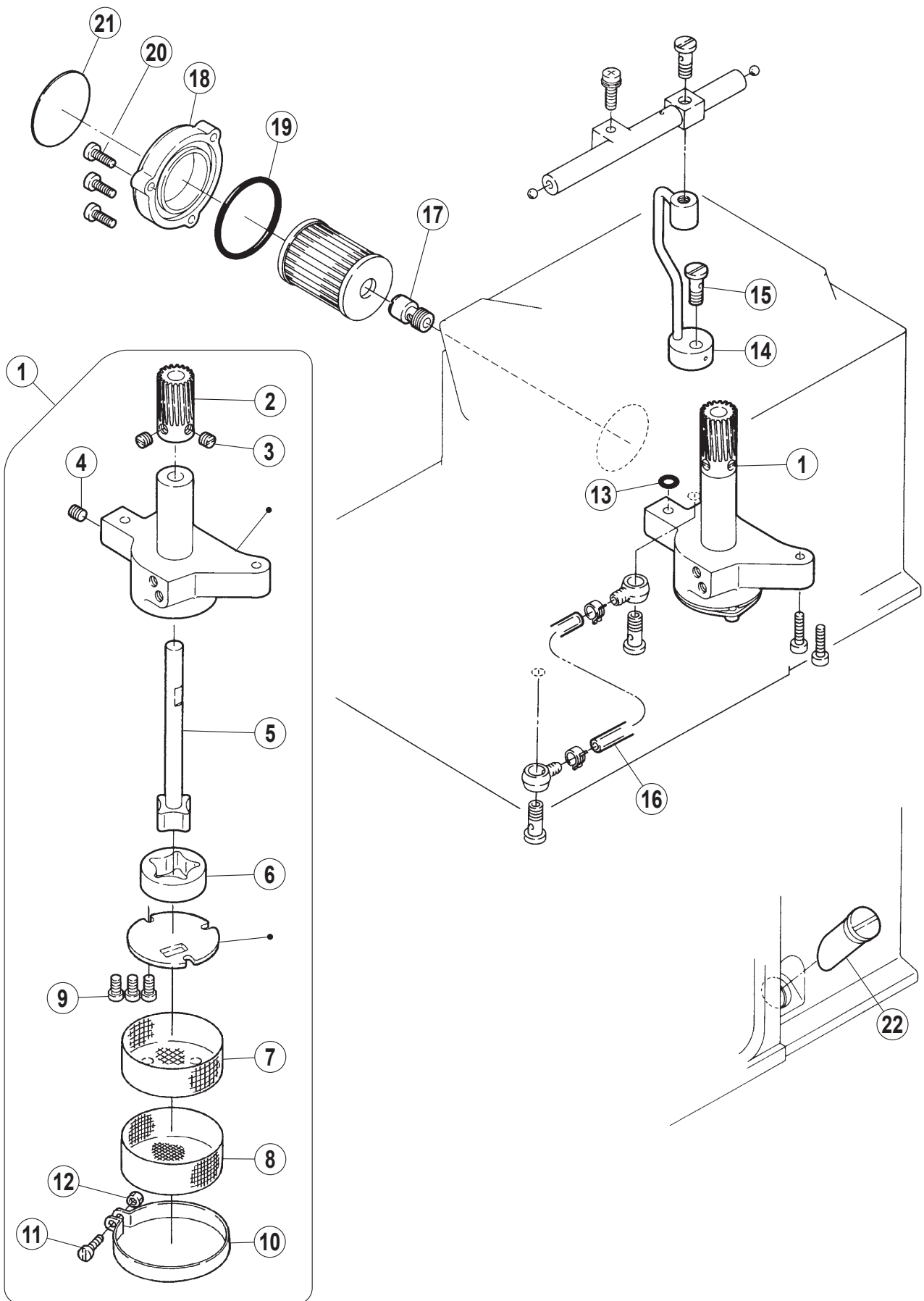

給油機構 (1)

LUBRICATION MECHANISM(1)

REF.NO.	PART NO.	部品名称	DESCRIPTION	QT.
1	274546-910	ポンプ (組)	OIL PUMP ASSY.	1
2	2116180	ウォームホイール	WORM WHEEL	1
3	0050600	止ネジ /C8X4.5	SCREW	2
4	0045220	六角穴止ネジ /6X6	SCREW	1
5	212978-910	ローター (内) 軸	ROTOR (INSIDE) SHAFT	1
6	2129810	ローター (外)	ROTOR (OUTSIDE)	1
7	2094080	フィルター	FILTER	1
8	2094090	フィルター	FILTER	1
9	0070120	平小ネジ /M3.5X6	SCREW	3
10	2094100	クランプ	CLAMP	1
11	0070110	平小ネジ /M3X8	SCREW	1
12	0048000	六角ナット /M3	NUT	1
13	2041850	Oリング	O RING	1
14	274532-910	油配分器	OIL DISTRIBUTOR	1
15	2403280	継手ネジ	JOINT SCREW	1
16	205113A0	給油パイプ	OIL TUBE	1
17	2745280	継手	JOINT	1
18	210201-SD0	フィルター蓋	COVER	1
19	2064310	Oリング	O RING	1
20	007021A0	十字穴ナベ小ネジ /M4X12	SCREW	3
21	9A30020	フィルターシール	FILTER SEAL	1
22	2745390	オイルゲージ	OIL LEVEL GAUGE	1

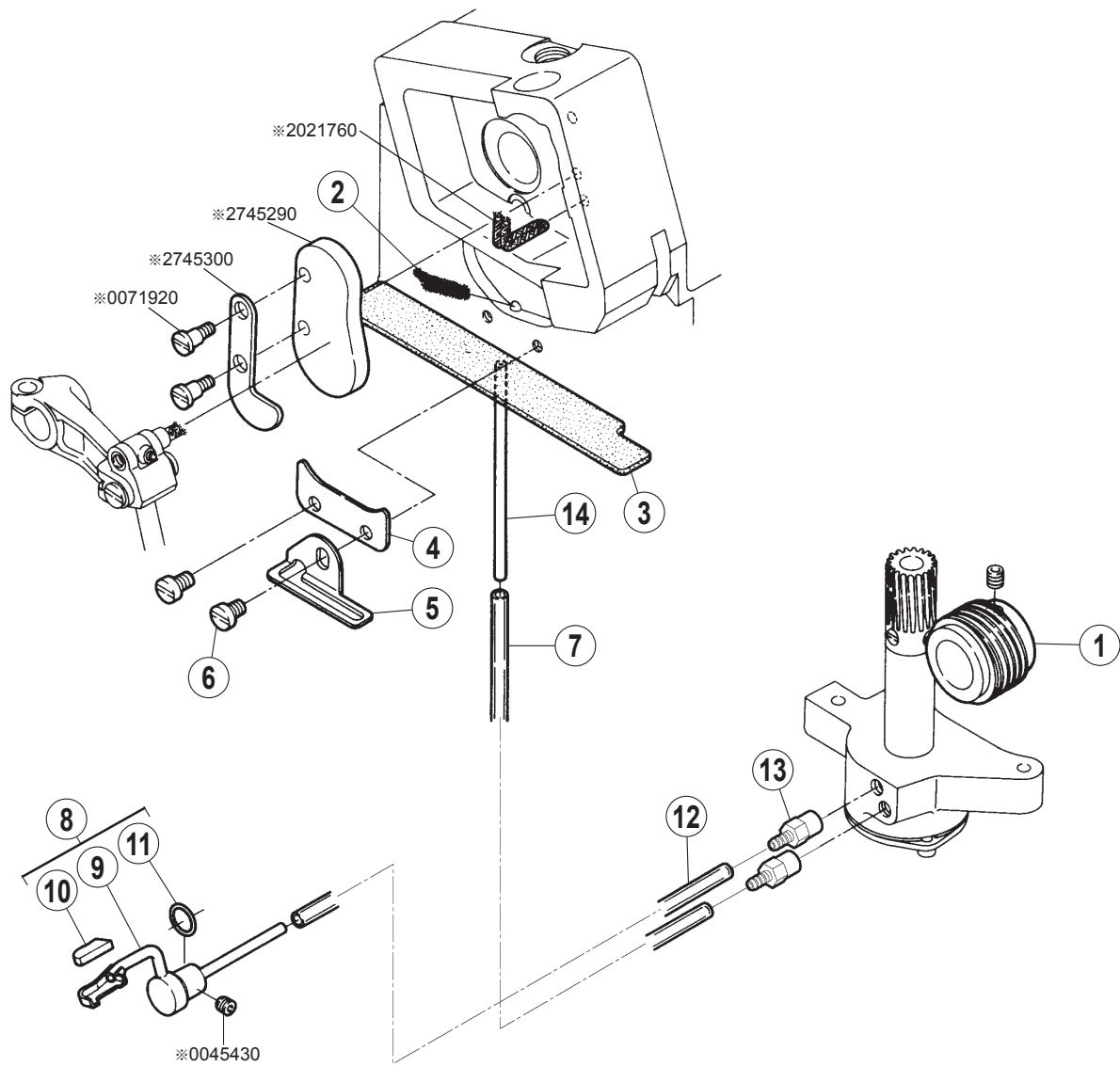

※印は、EX3200H・EX5200Hと共通使用部品です。
 Marked ※ parts are the common ones between
 EX3200H・EX5200H and EXT series

給油機構 (2)

LUBRICATION MECHANISM(2)

REF.NO.	PART NO.	部品名称	DESCRIPTION	QT.
1	2745070	ウォーム	WORM	1
2	2401520	モール	OIL WICK	1
3	2745490	フェルト	FELT	1
4	2745500	カバー	COVER	1
5	2745590	当金	SPACER	1
6	0070180	平小ネジ /M4X6	SCREW	2
7	2121520	チューブ	TUBE	1
8	274551A910	継手 (組)	JOINT ASSY.	1
9	274552A910	継手	JOINT	1
10	2745560	フェルト	FELT	1
11	2041850	Oリング	O RING	1
12	2403710	チューブ	TUBE	1
13	2745920	継手	JOINT	2
14	2123200	排油管	EXHAUST OIL DISTRIBUTOR	1

地縫い(Plain seaming)

EXT5204-02
EXT5214-03,M03

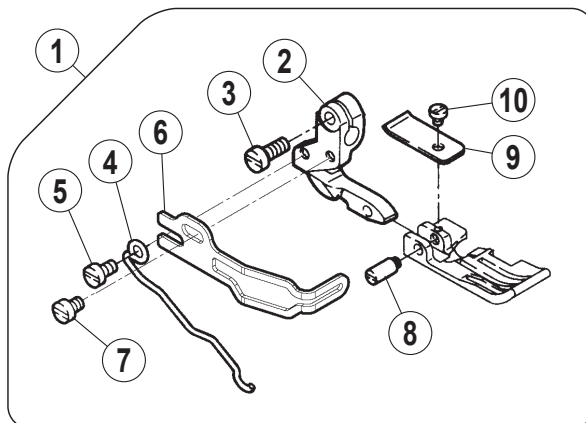

EXT3215(16)-02,03
EXT3244-03

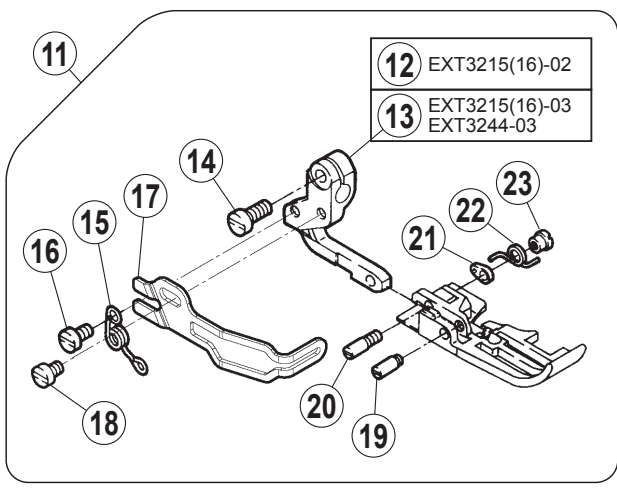

EXT3215(16)-03/433

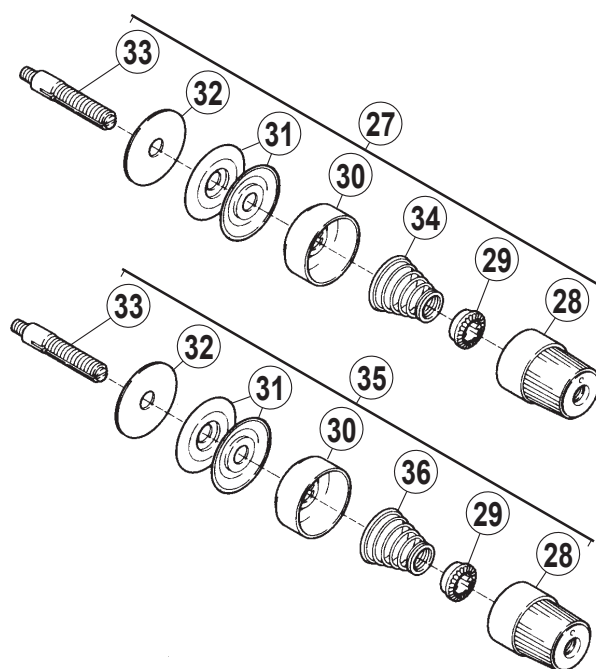
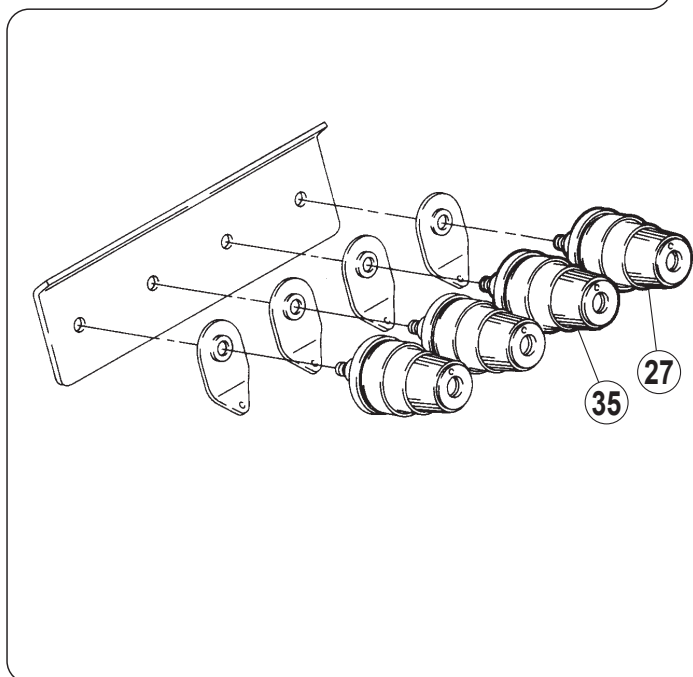
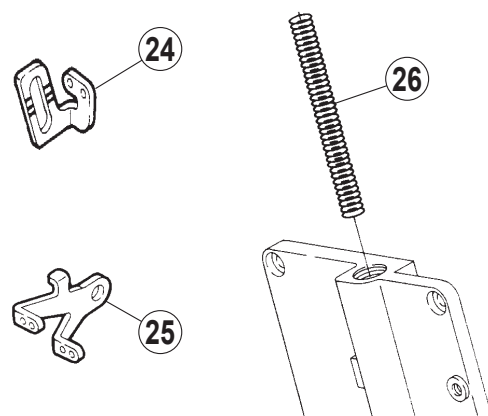

専用部品 (1)

SPECIFIC PARTS(1)

REF.NO.	PART NO.	部品名称	DESCRIPTION	QT.
1	XXXXXX	押工 (組)	PRESSER FOOT ASSY.	1
2	2771360	ホルダー	HOLDER	1
3	0070130	平小ネジ /M3.5X8	SCREW	1
4	2740510	ネジリバネ	SPRING	1
5	0070100	平小ネジ /M3X6	SCREW	1
6	2741060	フィンガーガード	FINGER GUARD	1
7	0070090	平小ネジ /M3X5	SCREW	1
8	212059-B0	ピンネジ	SCREW	1
9	2126680	押工補助板	PRESSER FOOT AUXILIARY PLATE	1
10	0050300	平ネジ /C1X2.3	SCREW	1
11	XXXXXX	押工 (組)	PRESSER FOOT ASSY.	1
12	2771380	ホルダー	HOLDER	1
13	2771390	ホルダー	HOLDER	1
14	0070130	平小ネジ /M3.5X8	SCREW	1
15	2740530	ネジリバネ	SPRING	1
16	0070100	平小ネジ /M3X6	SCREW	1
17	274106A0	フィンガーガード	FINGER GUARD	1
18	0070090	平小ネジ /M3X5	SCREW	1
19	209229-B0	ピンネジ	SCREW	1
20	209229AB0	ピンネジ	SCREW	1
21	2124980	ラッチ	LATCH	1
22	2740280	ネジリバネ	SPRING	1
23	0031530	段付ナット	NUT	1
24	2750080	糸道	THREAD GUIDE	1
25	2750090	糸繰り	THREAD TAKE-UP	1
26	2119410	圧縮バネ	SPRING	1
27	210530A9T0	糸調子 (組)	TENSION SPRING ASSY.	1
28	263543-TA0	ツマミ	KNOB	1
29	2084480	ラチェット	RATCHET	1
30	263544-TA0	受皿	SPRING SHIELD	1
31	2103190	調子皿	TENSION DISC	2
32	2084490	フェルト	FELT	1
33	005082A0	調子棒 /C5	SCREW STUD	1
34	201086A0	圧縮バネ (中)	SPRING(MEDIUM)	1
35	210531-9T0	糸調子 (組)	TENSION SPRING ASSY.	1
36	2010680	圧縮バネ (弱)	SPRING(LIGHT)	1

● xxxxxx はゲージパーツです。
部品番号は 48 ~ 55 頁のゲージパーツ表を
参照してください。

● "xxxxxx" represents the gauge part.
Please refer to the gauge part list (page48-55).

地縫い(Plain Seaming)
 EXT3215(16)-A04
 EXT3215(16)H-A05

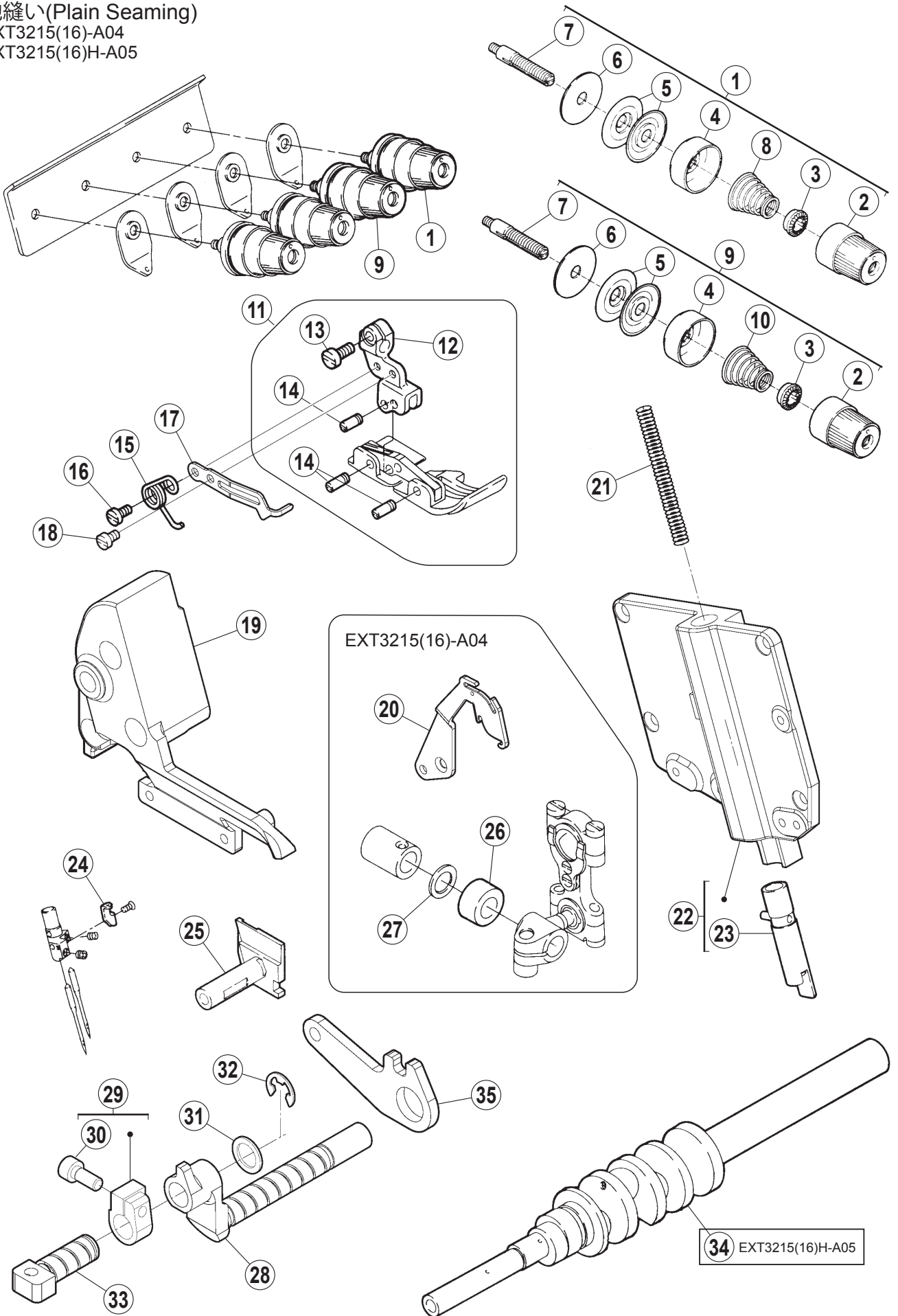

34 EXT3215(16)H-A05

専用部品 (2)

SPECIFIC PARTS(2)

REF.NO.	PART NO.	部品名称	DESCRIPTION	QT.
1	210530A9T0	糸調子 (組)	TENSION SPRING ASSY.	1
2	263543-TA0	ツマミ	KNOB	1
3	2084480	ラチェット	RATCHET	1
4	263544-TA0	受皿	SPRING SHIELD	1
5	2103190	調子皿	TENSION DISC	2
6	2084490	フェルト	FELT	1
7	005082A0	調子棒 /C5	SCREW STUD	1
8	201086A0	圧縮バネ (中)	SPRING(MEDIUM)	1
9	210531-9T0	糸調子 (組)	TENSION SPRING ASSY.	1
10	2010680	圧縮バネ (弱)	SPRING(LIGHT)	1
11	XXXXXX	押工 (組)	PRESSER FOOT ASSY.	1
12	2771300	ホルダー	HOLDER	1
13	0070130	平小ネジ /M3.5X8	SCREW	1
14	208958-B0	ピン	PIN	3
15	2740340	ネジリバネ	SPRING	1
16	0070090	平小ネジ /M3X5	SCREW	1
17	2741070	フィンガーガード	FINGER GUARD	1
18	0070080	平小ネジ /M3X4	SCREW	1
19	270068A0	ブラケット	BRACKET	1
20	2751230	針糸繰り	NEEDLE THREAD TAKE-UP	1
21	2403471	圧縮バネ	SPRING	1
22	270083D9U0	側面カバー (組)	SIDE COVER ASSY.	1
23	274116-910	押工棒	PRESSER BAR	1
24	275030A0	糸道	THREAD GUIDE	1
25	273009A0	下メス台	LOWER KNIFE HOLDER	1
26	2101220	スペーサー	SPACER	1
27	2405410	座金	WASHER	1
28	2741120	押工台軸	SHAFT	1
29	274114-920	カラー	COLLAR	1
30	0045310	六角穴ボルト /M5X12	BOLT	1
31	2401020	座金	WASHER	1
32	2050610	止メ輪	RETAINING RING	1
33	2741130	軸	SHAFT	1
34	270512B1	クランク軸	CRANKSHAFT	1
35	2741150	レバー	LEVER	1

● xxxxxx はゲージパーツです。
部品番号は 48 ~ 55 頁のゲージパーツ表を
参照してください。

● "xxxxxx" represents the gauge part.
Please refer to the gauge part list (page48-55).

地縫い(Plain Seaming)
EXT3244-A04

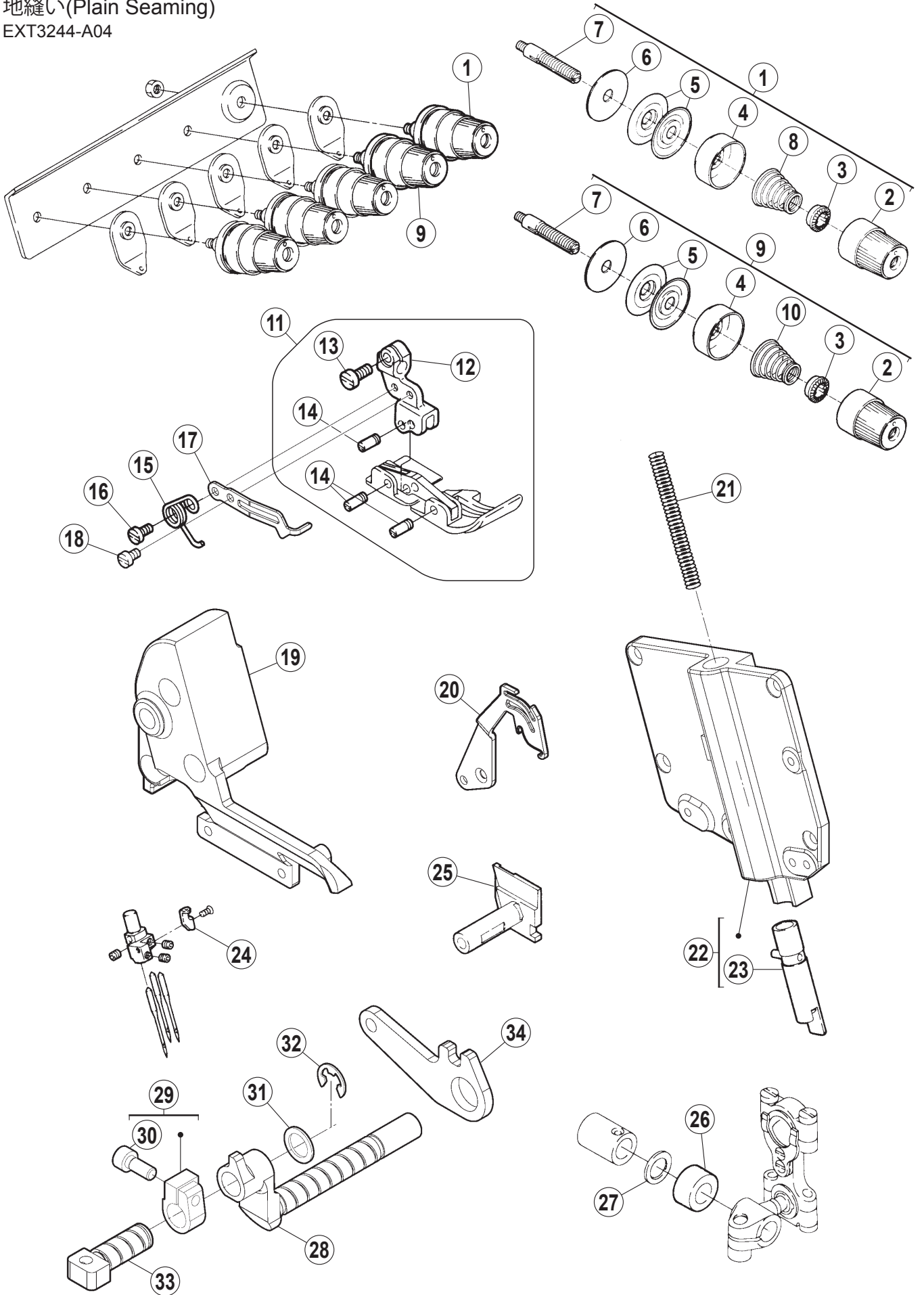

専用部品 (3)

SPECIFIC PARTS(3)

REF.NO.	PART NO.	部品名称	DESCRIPTION	QT.
1	210530A9T0	糸調子 (組)	TENSION SPRING ASSY.	1
2	263543-TA0	ツマミ	KNOB	1
3	2084480	ラチェット	RATCHET	1
4	263544-TA0	受皿	SPRING SHIELD	1
5	2103190	調子皿	TENSION DISC	2
6	2084490	フェルト	FELT	1
7	005082A0	調子棒 /C5	SCREW STUD	1
8	201086A0	圧縮バネ (中)	SPRING(MEDIUM)	1
9	210531-9T0	糸調子 (組)	TENSION SPRING ASSY.	1
10	2010680	圧縮バネ (弱)	SPRING(LIGHT)	1
11	XXXXXX	押工 (組)	PRESSER FOOT ASSY.	1
12	2771300	ホルダー	HOLDER	1
13	0070130	平小ネジ /M3.5X8	SCREW	1
14	208958-B0	ピン	PIN	3
15	2740340	ネジリバネ	SPRING	1
16	0070090	平小ネジ /M3X5	SCREW	1
17	2741070	フィンガーガード	FINGER GUARD	1
18	0070080	平小ネジ /M3X4	SCREW	1
19	270068A0	ブラケット	BRACKET	1
20	275123A0	針糸繰り	NEEDLE THREAD TAKE-UP	1
21	2403471	圧縮バネ	SPRING	1
22	270083D9U0	側面カバー (組)	SIDE COVER ASSY.	1
23	274116-910	押工棒	PRESSER BAR	1
24	275030A0	糸道	THREAD GUIDE	1
25	273009A0	下メス台	LOWER KNIFE HOLDER	1
26	2403020	スペーサー	SPACER	1
27	2405410	座金	WASHER	1
28	2741120	押工台軸	SHAFT	1
29	274114-920	カラー	COLLAR	1
30	0045310	六角穴ボルト /M5X12	BOLT	1
31	2401020	座金	WASHER	1
32	2050610	止メ輪	RETAINING RING	1
33	2741130	軸	SHAFT	1
34	2741150	レバー	LEVER	1

● xxxxxx はゲージパーツです。
部品番号は 48 ~ 55 頁のゲージパーツ表を
参照してください。

● "xxxxxx" represents the gauge part.
Please refer to the gauge part list (page48-55).

地縫い(Plain seaming)
EXT3215(16)-B-04

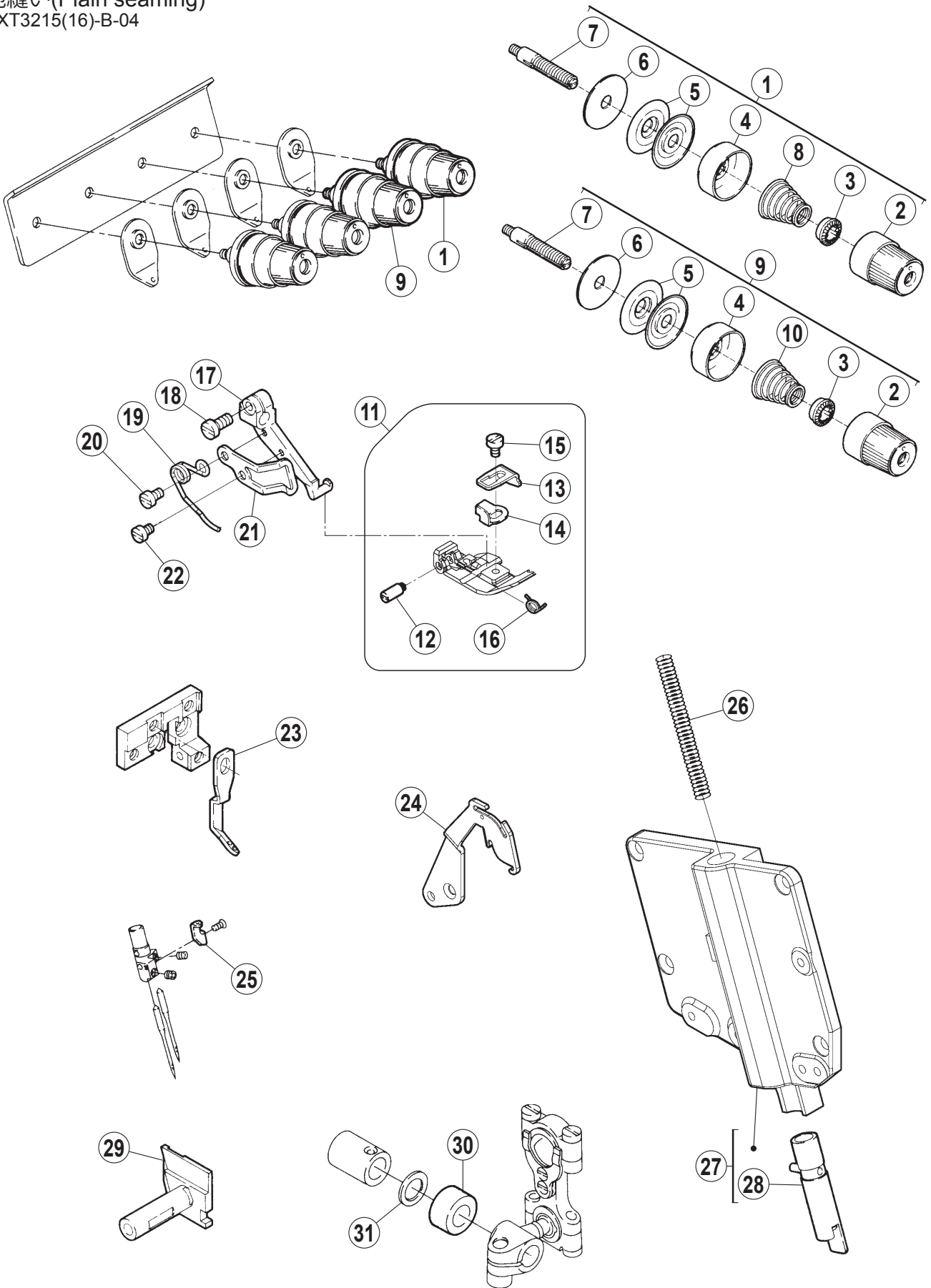

専用部品 (4)

SPECIFIC PARTS(4)

REF.NO.	PART NO.	部品名称	DESCRIPTION	QT.
1	210530A9T0	糸調子 (組)	TENSION SPRING ASSY.	1
2	263543-TA0	ツマミ	KNOB	1
3	2084480	ラチェット	RATCHET	1
4	263544-TA0	受皿	SPRING SHIELD	1
5	2103190	調子皿	TENSION DISC	2
6	2084490	フェルト	FELT	1
7	005082A0	調子棒 /C5	SCREW STUD	1
8	201086A0	圧縮バネ (中)	SPRING(MEDIUM)	1
9	210531-9T0	糸調子 (組)	TENSION SPRING ASSY.	1
10	2010680	圧縮バネ (弱)	SPRING(LIGHT)	1
11	XXXXXX	押工 (組)	PRESSER FOOT ASSY.	1
12	212059-B0	ピンネジ	SCREW	1
13	2120610	補助押工	FABRIC GUIDE	1
14	2119170	取付板	BRACKET	1
15	0029210	平小ネジ /C3X4	SCREW	1
16	2120600	線細工バネ	SPRING	1
17	274021-92B0	ホルダー	HOLDER	1
18	0070130	平小ネジ /M3.5X8	SCREW	1
19	2740660	ネジリバネ	SPRING	1
20	0070090	平小ネジ /M3X5	SCREW	1
21	274025A0	フィンガーガード	FINGER GUARD	1
22	0070080	平小ネジ /M3X4	SCREW	1
23	2750570	糸道	THREAD GUIDE	1
24	2751230	針糸繰り	NEEDLE THREAD TAKE-UP	1
25	275030A0	糸道	THREAD GUIDE	1
26	2403471	圧縮バネ	SPRING	1
27	270083D9U0	側面カバー (組)	SIDE COVER ASSY.	1
28	274116-910	押工棒	PRESSER BAR	1
29	273009A0	下メス台	LOWER KNIFE HOLDER	1
30	2101220	スペーサー	SPACER	1
31	2405410	座金	WASHER	1

● xxxxxx はゲージパーツです。
部品番号は 48 ~ 55 頁のゲージパーツ表を
参照してください。

● "xxxxxx" represents the gauge part.
Please refer to the gauge part list (page48-55).

裾引き(Blindhemming)

EXT5205-12

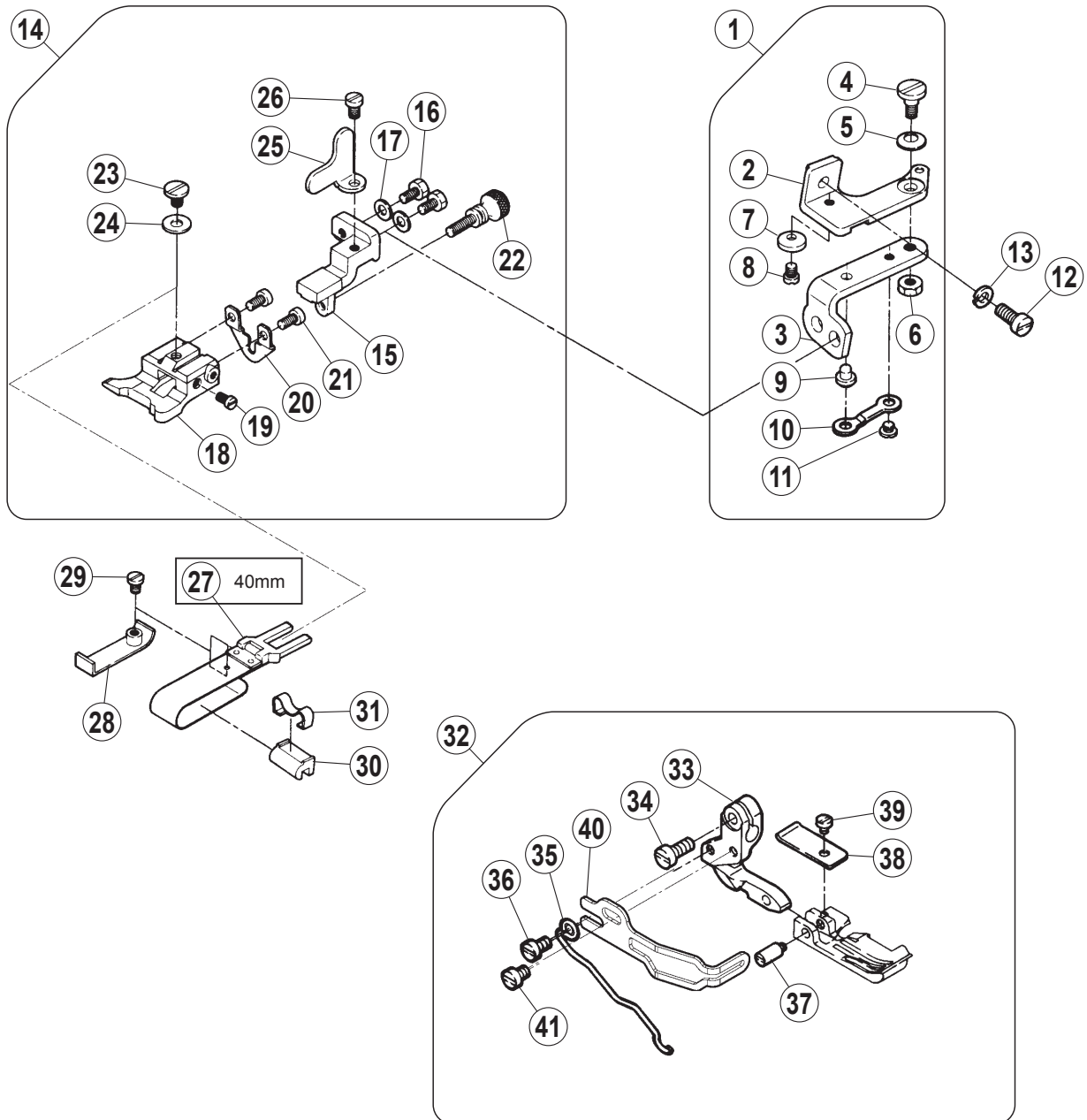

専用部品 (5)

SPECIFIC PARTS(5)

REF.NO.	PART NO.	部品名称	DESCRIPTION	QT.
1	2106850	定規ブラケット (組)	CLOTH GUIDE BRACKET ASSY.	1
2	2106800	定規ブラケット	CLOTH GUIDE BRACKET	1
3	2106810	ヒンジ / 定規ブラケット	HINGE/EDGE GUIDE BRACKET	1
4	0051840	段ネジ / C5	SCREW	1
5	2011910	皿バネ	SPRING	1
6	0030440	六角ナット / C5	NUT	1
7	2106820	ストッパー	STOPPER	1
8	0050530	平ネジ / C4X4.8	SCREW	1
9	2106830	ピン	PIN	1
10	2106840	板バネ	FLAT SPRING	1
11	0029060	平ネジ / C4X2.6	SCREW	1
12	0070200	平小ネジ / M4X10	SCREW	1
13	2012520	バネ座金	WASHER	1
14	2106910	裾引定規台 (組)	CLOTH GUIDE ASSY.	1
15	2106900	ブラケット	BRACKET	1
16	0050880	六角ボルト / C4X7.5	BOLT	2
17	1670660	座金	WASHER	2
18	2053610	ブラケット	BRACKET	1
19	0050570	平ネジ / C3X5	SCREW	1
20	2106890	調節板	ADJUSTING PLATE	1
21	0051570	平ネジ / C3X4.5	SCREW	2
22	0024300	調節ネジ / C3	SCREW	1
23	0029050	平ネジ / C5X4.5	SCREW	1
24	1371420	座金	WASHER	1
25	2106920	ストッパー	STOPPER	1
26	0012060	平ネジ / C4X5.3	SCREW	1
27	201211C910	定規羽根 (組) (40mm)	FOLDER ASSY.(40mm)	1
28	2058350	補助羽根	AUXILIARY PLATE	1
29	0052990	平ネジ / C3X2.6	SCREW	1
30	303312A0	ストッパー	STOPPER	1
31	3033130	クランプ	CLAMP	1
32	XXXXXX	押エ (組)	PRESSER FOOT ASSY.	1
33	2771360	ホルダー	HOLDER	1
34	0070130	平小ネジ / M3.5X8	SCREW	1
35	2740510	ネジリバネ	SPRING	1
36	0070100	平小ネジ / M3X6	SCREW	1
37	212059-B0	ピンネジ	SCREW	1
38	2126680	押エ補助板	PRESSER FOOT AUXILIARY PLATE	1
39	0050300	平ネジ / C1X2.3	SCREW	1
40	2741060	フィンガーガード	FINGER GUARD	1
41	0070090	平小ネジ / M3X5	SCREW	1

● xxxxxx はゲージパーツです。
部品番号は 48 ~ 55 頁のゲージパーツ表を
参照してください。

● "xxxxxx" represents the gauge part.
Please refer to the gauge part list (page48-55).

ヒタ取り(Shirring)
 EXT3215(16)-42
 EXT5214-43,54S2

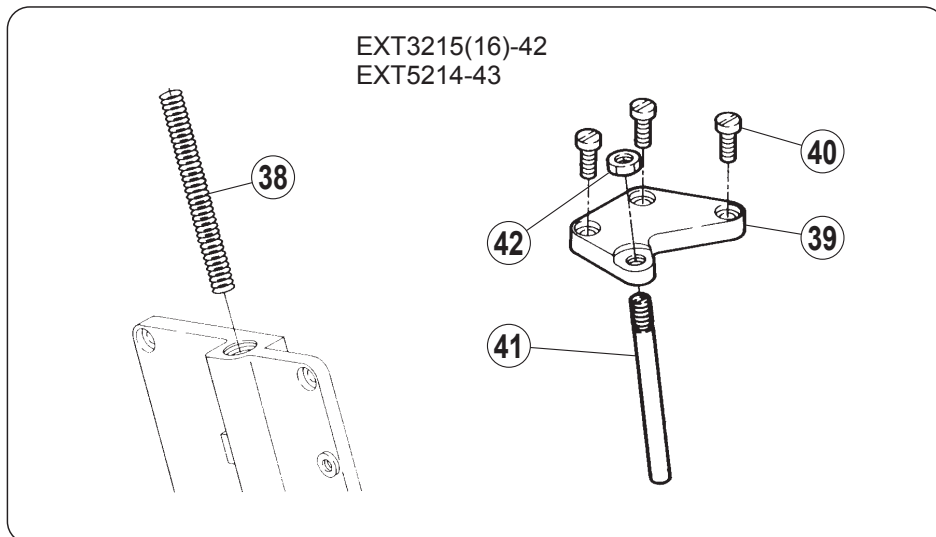
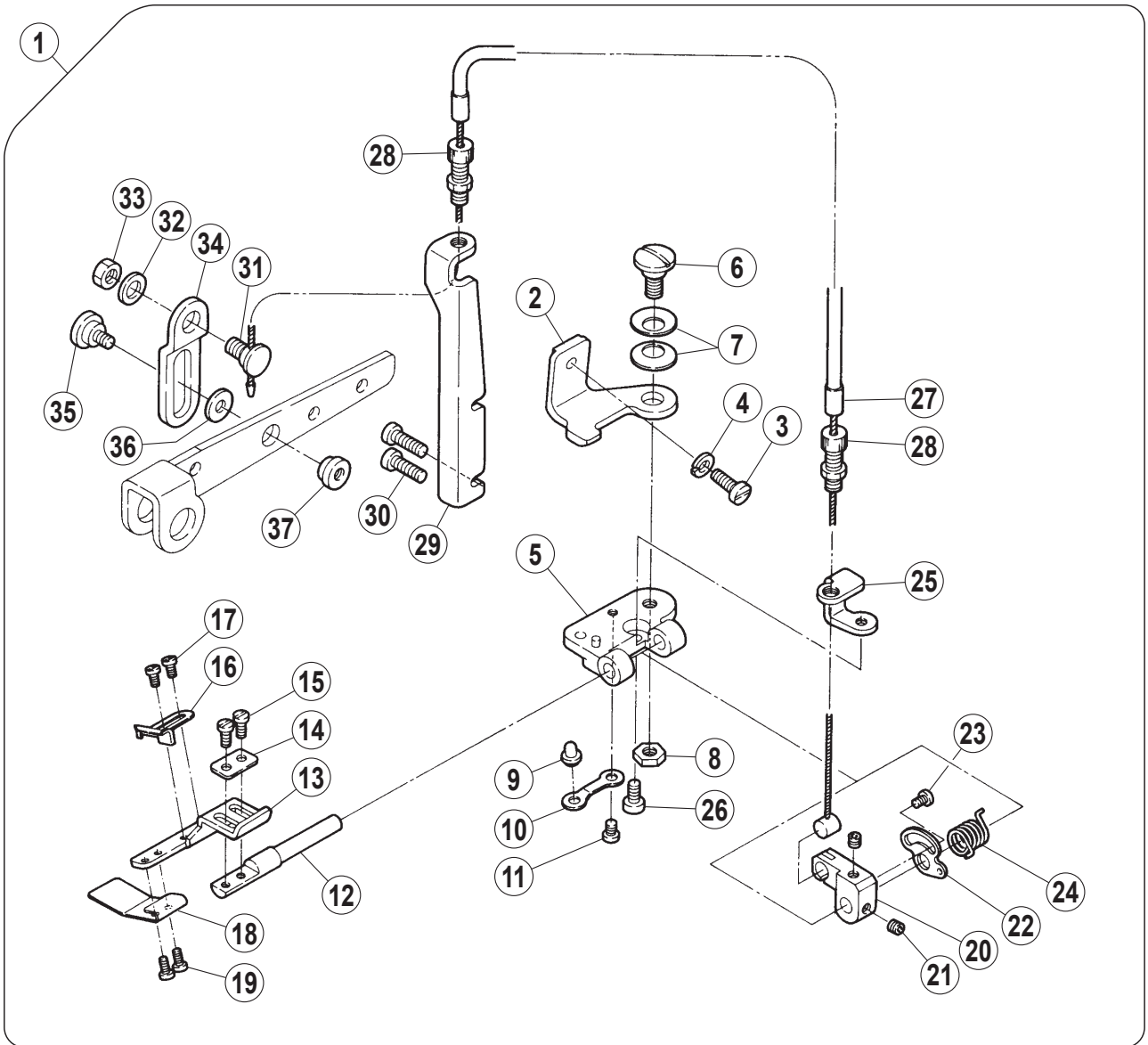

専用部品 (6)

SPECIFIC PARTS(6)

REF.NO.	PART NO.	部品名称	DESCRIPTION	QT.
1	275532-910	ヒダ取装置 (組)	SHRRING ATTACHMENT ASSY.	1
2	2755330	ブラケット	BRACKET	1
3	0070200	平小ネジ /M4X10	SCREW	1
4	2012520	バネ座金	WASHER	1
5	2126010	ブラケット	BRACKET	1
6	0053800	段付ネジ /C8	STUD	1
7	2048880	皿バネ	SPRING	2
8	0051040	六角ナット /C8	NUT	1
9	2106830	ピン	PIN	1
10	2106840	板バネ	FLAT SPRING	1
11	0012340	平ネジ /C4X3.8	SCREW	1
12	2126030	軸	SHAFT	1
13	2755390	ブラケット	BRACKET	1
14	2109550	座金	WASHER	1
15	0011960	平ネジ /C3X6.5	SCREW	2
16	2126600	布ガイド	CLOTH GUIDE	1
17	0050770	平ネジ /C1X3	SCREW	2
18	2126580	ブレード	SHIRRING BLADE	1
19	0050770	平ネジ /C1X3	SCREW	2
20	2755340	ブラケット	BRACKET	1
21	0045430	六角穴止ネジ /M4X4	SCREW	2
22	2755350	ラッチ	LATCH	1
23	0070080	平小ネジ /M3X4	SCREW	1
24	2755370	ネジリバネ	SPRING	1
25	2755360	ブラケット	BRACKET	1
26	007021A0	十字穴ナベ小ネジ /M4X12	SCREW	1
27	2124350	ケーブル	CABLE	1
28	2124360	ケーブル受ケ	CABLE SUPPORT	2
29	2755230	ブラケット	BRACKET	1
30	007022A0	十字穴ナベ小ネジ /M4X14	SCREW	2
31	0070990	段ネジ /M6	SCREW	1
32	2024330	座金	WASHER	1
33	0048060	六角ナット /M6	NUT	1
34	2755220	ラッチ	LATCH	1
35	0071640	段付ネジ /M4	SCREW	1
36	2401040	座金	WASHER	1
37	179765-150	ナット /M4	NUT	1
38	2119410	圧縮バネ	SPRING	1
39	2765210	ブラケット	BRACKET	1
40	007021A0	十字穴ナベ小ネジ /M4X12	SCREW	3
41	2765220	ストッパー	STOPPER	1
42	0072070	六角ナット /M6	NUT	1

ヒダ取り(Shirring)

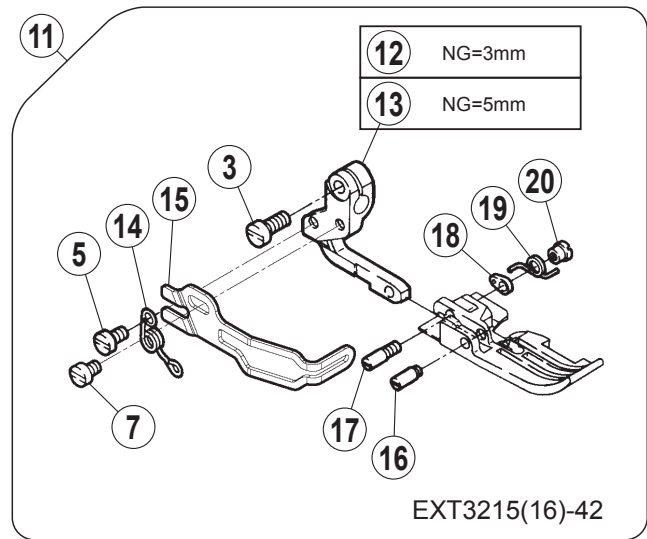
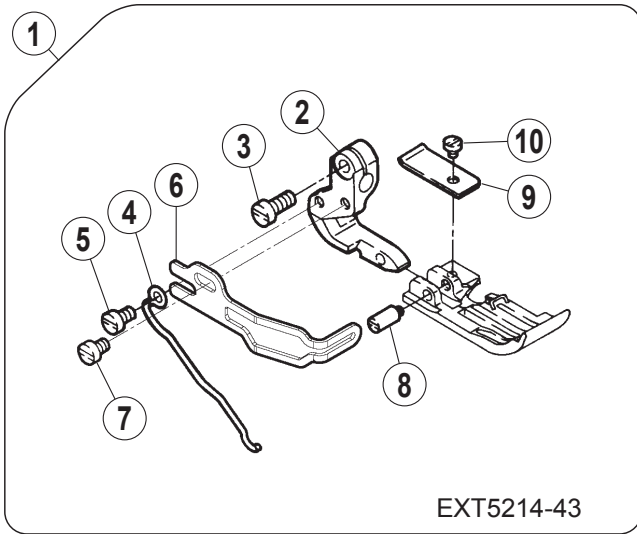

家具用パイピング(Piping on upholstery)
EXT3216H-45P1,C5P1

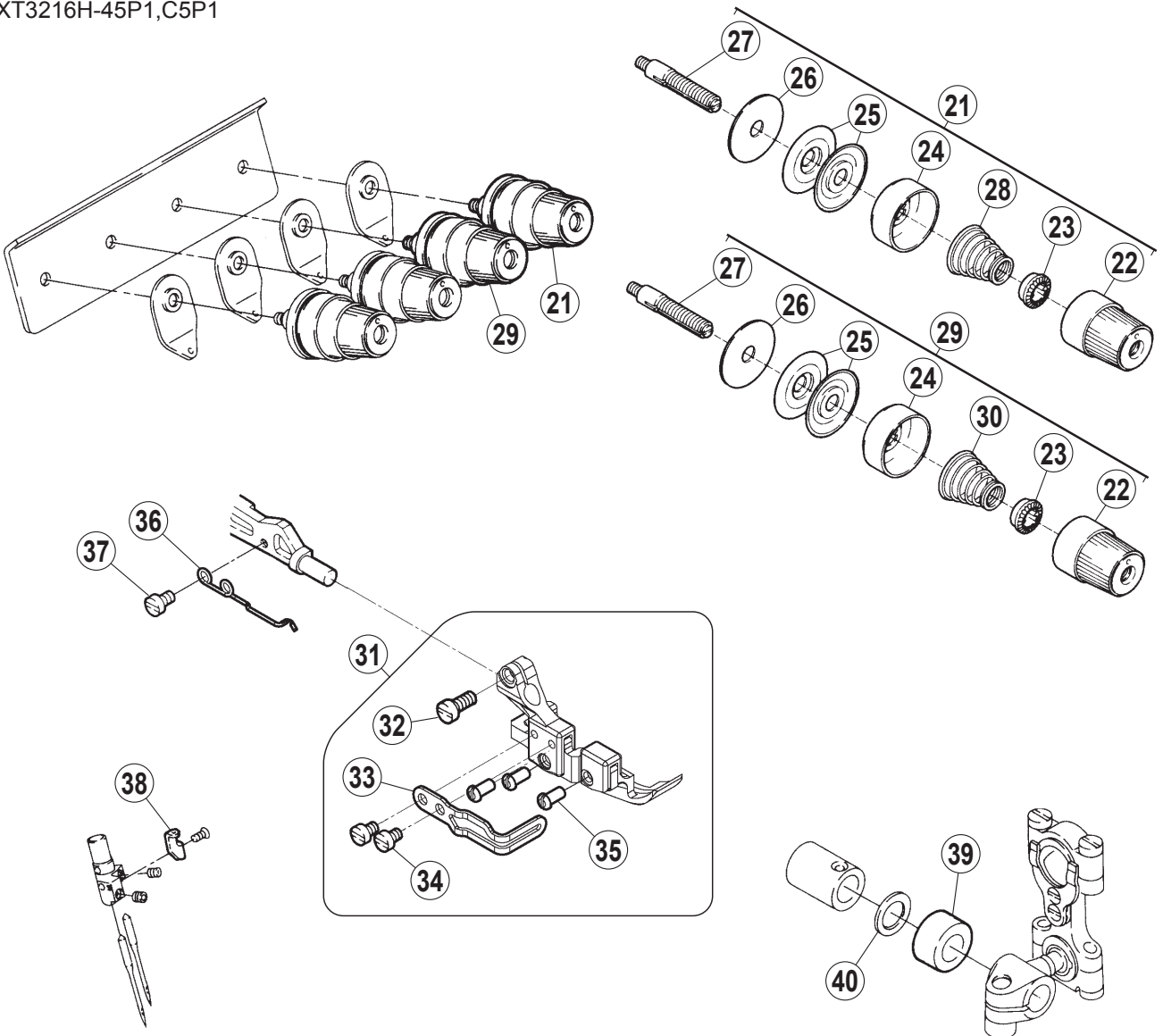

専用部品 (7)

SPECIFIC PARTS(7)

REF.NO.	PART NO.	部品名称	DESCRIPTION	QT.
1	XXXXXX	押工 (組)	PRESSER FOOT ASSY.	1
2	2771370	ホルダー	HOLDER	1
3	0070130	平小ネジ /M3.5X8	SCREW	1
4	2740520	ネジリバネ	SPRING	1
5	0070100	平小ネジ /M3X6	SCREW	1
6	2741060	フィンガーガード	FINGER GUARD	1
7	0070090	平小ネジ /M3X5	SCREW	1
8	212059-B0	ピンネジ	SCREW	1
9	2126680	押工補助板	PRESSER FOOT AUXILIARY PLATE	1
10	0050300	平ネジ /C1X2.3	SCREW	1
11	XXXXXX	押工 (組)	PRESSER FOOT ASSY.	1
12	2771380	ホルダー	HOLDER	1
13	2771390	ホルダー	HOLDER	1
14	2740530	ネジリバネ	SPRING	1
15	274106A0	フィンガーガード	FINGER GUARD	1
16	209229-B0	ピンネジ	SCREW	1
17	209229AB0	ピンネジ	SCREW	1
18	2124980	ラッチ	LATCH	1
19	2740560	ネジリバネ	SPRING	1
20	0031530	段付ナット	NUT	1
21	210530A9T0	糸調子 (組)	TENSION SPRING ASSY.	1
22	263543-TA0	ツマミ	KNOB	1
23	2084480	ラチェット	RATCHET	1
24	263544-TA0	受皿	SPRING SHIELD	1
25	2103190	調子皿	TENSION DISC	2
26	2084490	フェルト	FELT	1
27	005082A0	調子棒 /C5	SCREW STUD	1
28	201086A0	圧縮バネ (中)	SPRING(MEDIUM)	1
29	210531-9T0	糸調子 (組)	TENSION SPRING ASSY.	1
30	2010680	圧縮バネ (弱)	SPRING(LIGHT)	1
31	XXXXXX	押工 (組)	PRESSER FOOT ASSY.	1
32	0070130	平小ネジ /M3.5X8	SCREW	1
33	2741080	フィンガーガード	FINGER GUARD	1
34	0070070	平小ネジ /M3X3	SCREW	2
35	0072670	平小ネジ /M3X6.5	SCREW	3
36	2740980	ネジリバネ	SPRING	1
37	0070080	平小ネジ /M3X4	SCREW	1
38	275030A0	糸道	THREADE GUIDE	1
39	2101220	スペーサー	SPACER	1
40	2401020	座金	WASHER	1

● xxxxxx はゲージパーツです。
部品番号は 48 ~ 55 頁のゲージパーツ表を
参照してください。

● "xxxxxx" represents the gauge part.
Please refer to the gauge part list (page48-55).

家具用パイピング(Piping on upholstery)
EXT3216H-45P1,C5P1

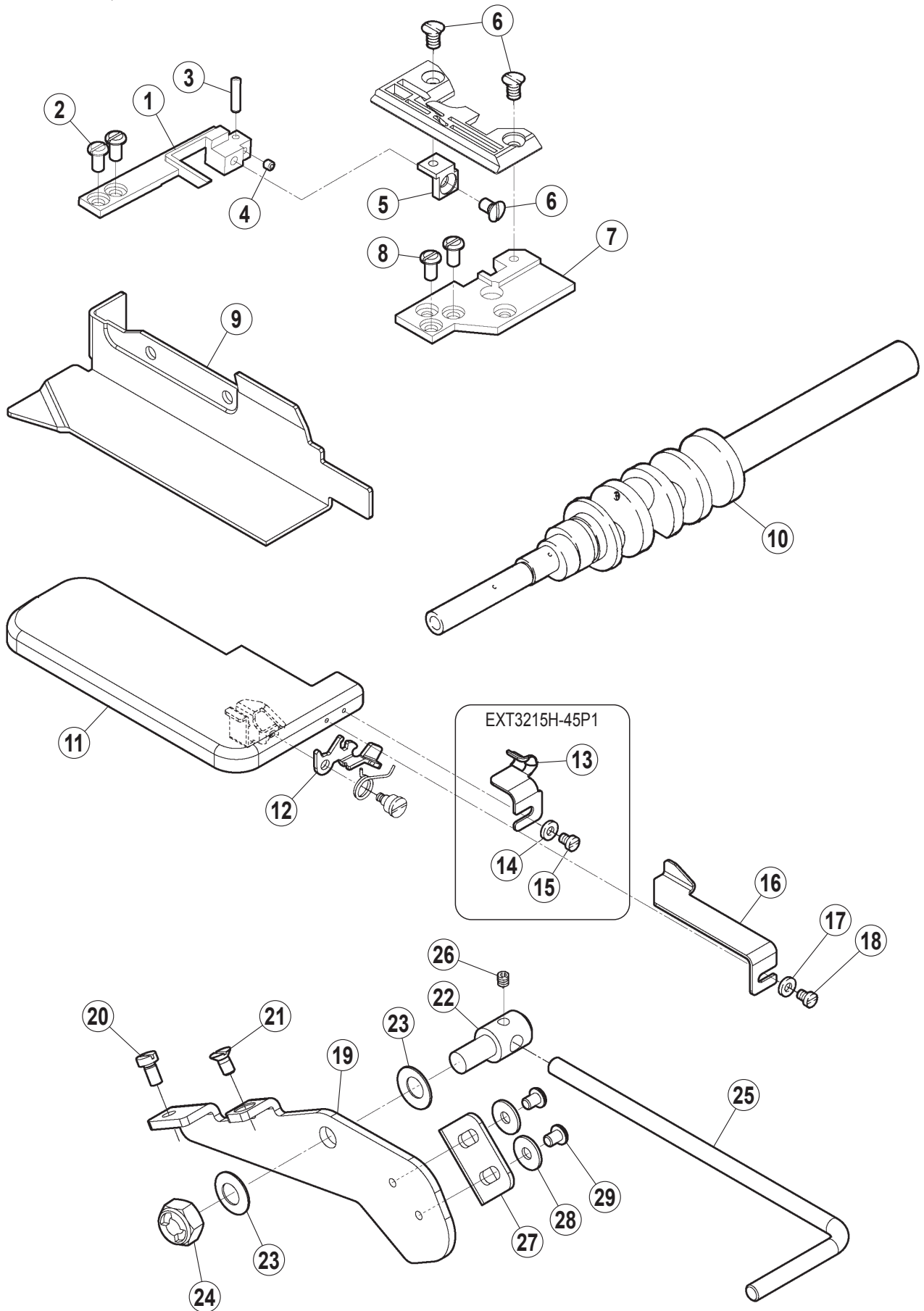

専用部品 (8)

SPECIFIC PARTS(8)

REF.NO.	PART NO.	部品名称	DESCRIPTION	QT.
1	2710380	取付板 (後)	BRACKET(REAR)	1
2	0070820	ナベ小ネジ /M4X8	SCREW	2
3	0045740	六角穴止ネジ /M3X12	SCREW	1
4	0045540	六角穴止ネジ /M3X3	SCREW	1
5	2710370	ブラケット	BRACKET	1
6	0071700	皿小ネジ /M4X7.5	SCREW	3
7	2710390	取付板 (前)	BRACKET(FRONT)	1
8	0070820	ナベ小ネジ /M4X8	SCREW	2
9	270140-910	布案内	FABRIC GUIDE	1
10	270512B1	クランク軸	CRANKSHAFT	1
11	270138-910	クロスプレート	CLOTH PLATE	
12	2701420	レバー	LEVER	1
13	2755680	布案内	FABRIC GUIDE	1
14	1379060	座金	WASHER	1
15	0070120	平小ネジ /M3.5X6	SCREW	1
16	2755650	テープガイド	TAPE GUIDE	1
17	1379060	座金	WASHER	1
18	0070120	平小ネジ /M3.5X6	SCREW	1
19	2755610	ブラケット	BRACKET	1
20	0070190	平小ネジ /M4X8	SCREW	1
21	0070430	皿小ネジ /M4X8	SCREW	1
22	2755630	継手ネジ	JOINT SCREW	1
23	2048880	皿バネ	SPRING	2
24	0048340	ナット /M8	NUT	1
25	2755620	取付棒	FIXING ROD	1
26	0045140	六角穴止ネジ /M5X5	SCREW	1
27	2755640	ストッパー	STOPPER	1
28	2401040	座金	WASHER	2
29	0071430	ナベ小ネジ /M4X5.5	SCREW	2

家具用パイピング・ヒダ取り(Piping on upholstery・Shirring)
EXT3216H-45P1

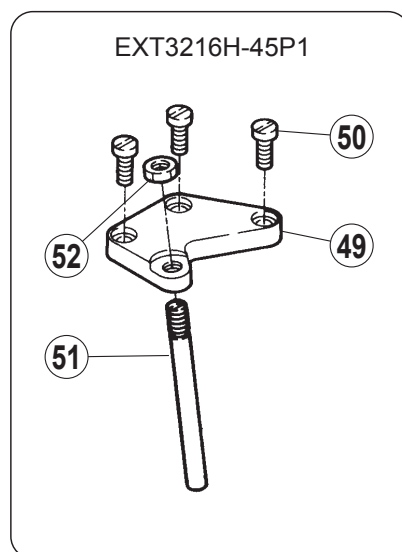
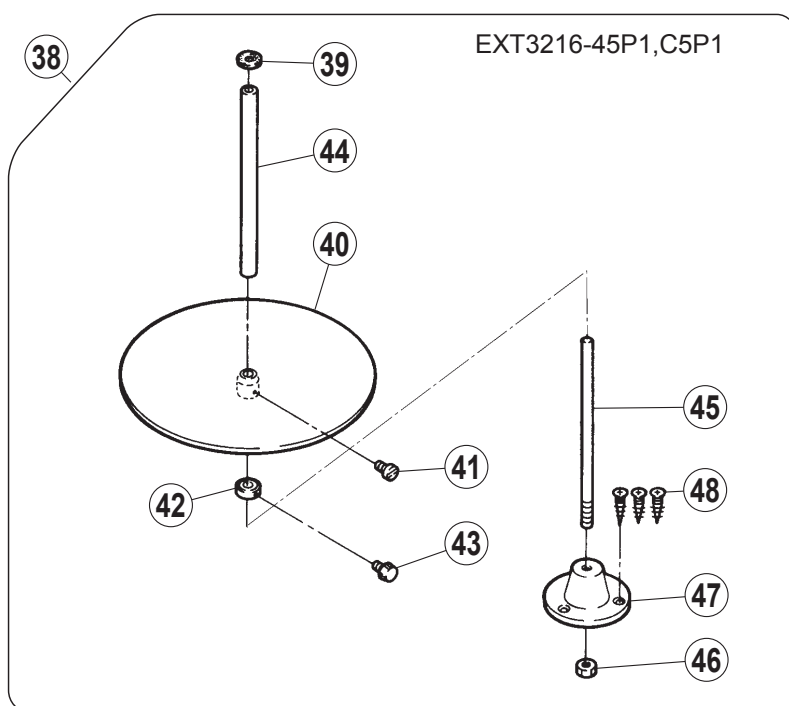
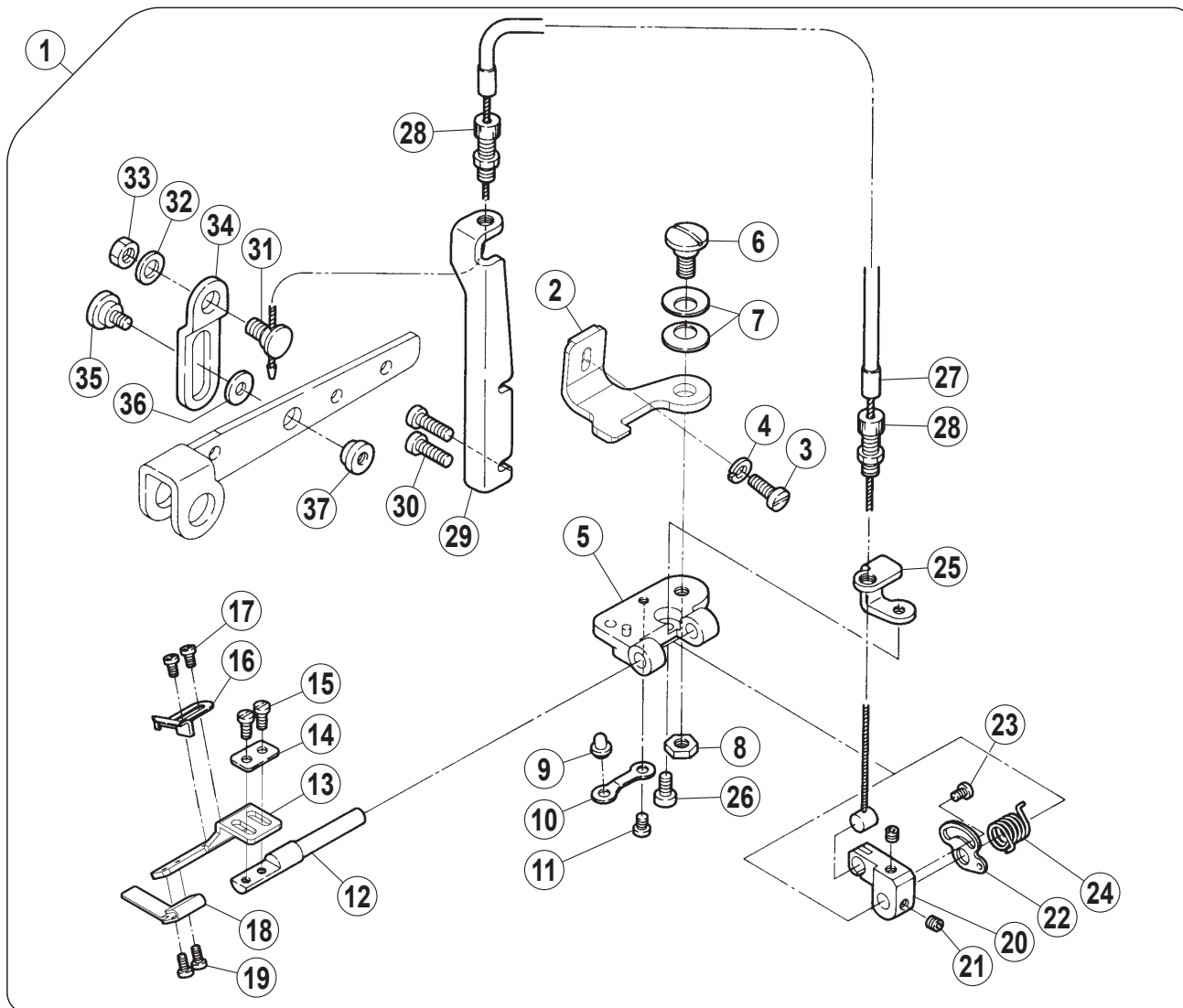

専用部品 (9)

SPECIFIC PARTS(9)

REF.NO.	PART NO.	部品名称	DESCRIPTION	QT.
1	275566-910	ヒダ取り装置 (組)	SHIRRING ATTACHMENT ASSY.	1
2	2755670	ブラケット	BRACKET	1
3	0070200	平小ネジ /M4X10	SCREW	1
4	2012520	バネ座金	WASHER	1
5	2126010	ブラケット	BRACKET	1
6	0053800	段付ネジ /C8	STUD	2
7	2048880	皿バネ	SPRING	1
8	0051040	六角ナット /C8	NUT	1
9	2106830	ピン	PIN	1
10	2106840	板バネ	FLAT SPRING	1
11	0012340	平ネジ /C4X3.8	SCREW	1
12	2126030	軸	SHAFT	1
13	212659A0	ブラケット	BRACKET	1
14	2109550	座金	WASHER	1
15	0011960	平ネジ /C3X6.5	SCREW	2
16	2126600	布ガイド	CLOTH GUIDE	1
17	0050770	平ネジ /C1X3	SCREW	2
18	2755690	ブレード	SHIRRING BLADE	1
19	0050770	平ネジ /C1X3	SCREW	2
20	2755340	ブラケット	BRACKET	1
21	0045430	六角穴止ネジ /M4X4	SCREW	2
22	2755350	ラッチ	LATCH	1
23	0070080	平小ネジ /M3X4	SCREW	1
24	2755370	ネジリバネ	SPRING	1
25	2755360	ブラケット	BRACKET	1
26	007021A0	十字穴ナベ小ネジ /M4X12	SCREW	1
27	2124350	ケーブル	CABLE	1
28	2124360	ケーブル受ケ	CABLE SUPPORT	2
29	2755230	ブラケット	BRACKET	1
30	007022A0	十字穴ナベ小ネジ /M4X14	SCREW	2
31	0070990	段ネジ /M6	SCREW	1
32	2024330	座金	WASHER	1
33	0048060	六角ナット /M6	NUT	1
34	2755220	ラッチ	LATCH	1
35	0071640	段付ネジ /M4	SCREW	1
36	2401040	座金	WASHER	1
37	179765-150	ナット /M4	NUT	1
38	000403-9S0	テープガイド (組)	TAPE DISC ASSY.	1
39	0004060	フェルト	FELT	1
40	0004040	カノコ台	TAPE DISC	1
41	0040120	平ネジ /M4X12	SCREW	1
42	0004070	カラー	COLLAR	1
43	0004080	調節ネジ /M4	SCREW	1
44	0004050	取付棒	BAR	1
45	0004090	取付軸	SHAFT	1
46	0048180	六角ナット /M6	NUT	1
47	000410-SA0	ブラケット	BRACKET	1
48	0049080	木ネジ /4.5	SCREW	3
49	2765210	ブラケット	BRACKET	1
50	007021A0	十字穴ナベ小ネジ /M4X12	SCREW	3
51	2765220	ストッパー	STOPPER	1
52	0072070	六角ナット /M6	NUT	1

パイピング(Piping)

EXT3215(16)-C3P1,C3P2
EXT5214-C3P1,C3P2

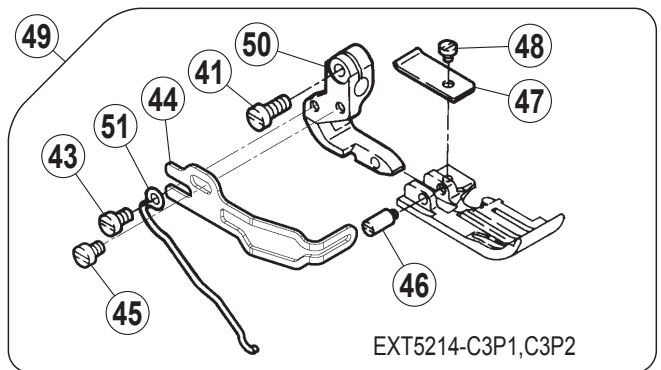
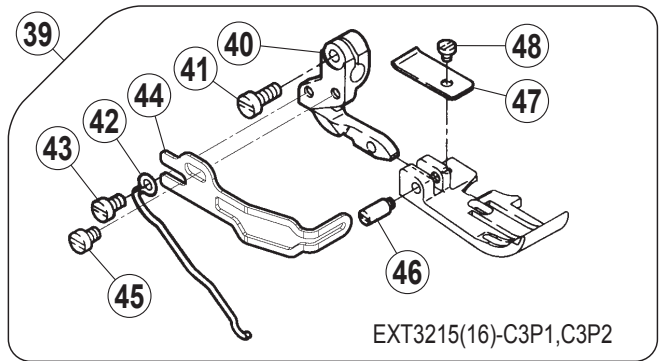
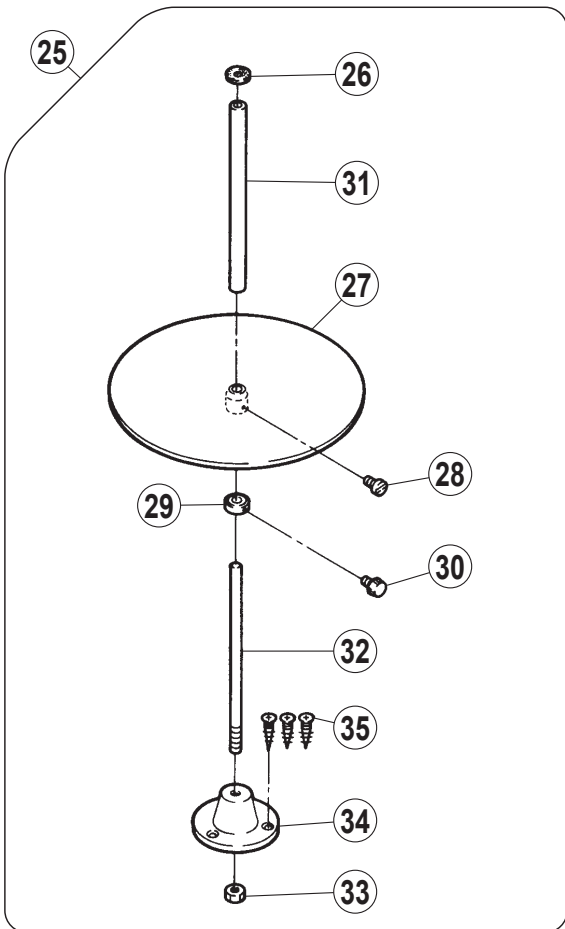
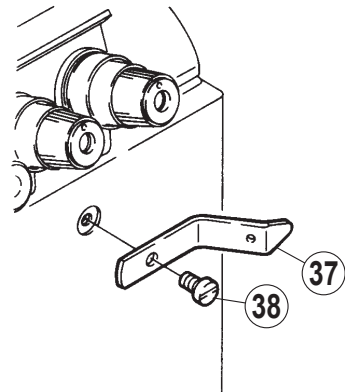
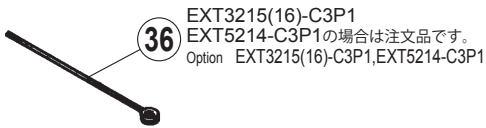
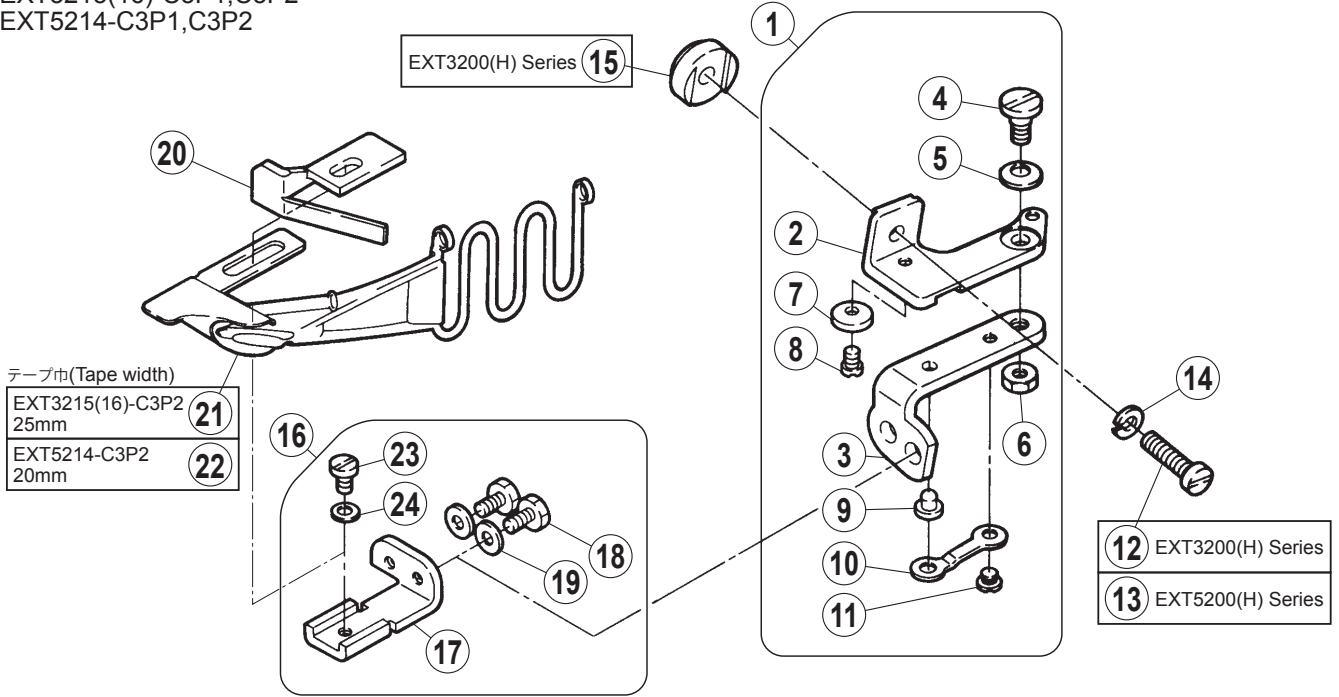

専用部品 (10)

SEPCIFIC PARTS(10)

REF.NO.	PART NO.	部品名称	DESCRIPTION	QT.
1	2106850	定規ブラケット (組)	CLOTH GUIDE BRACKET ASSY.	1
2	2106800	定規ブラケット	CLOTH GUIDE BRACKET	1
3	2106810	ヒンジ / 定規ブラケット	HINGE/EDGE GUIDE BRACKET	1
4	0051840	段ネジ /C5	SCREW	1
5	2011910	皿バネ	SPRING	1
6	0030440	六角ナット /C5	NUT	1
7	2106820	ストッパー	STOPPER	1
8	0050530	平ネジ /C4X4.8	SCREW	1
9	2106830	ピン	PIN	1
10	2106840	板バネ	FLAT SPRING	1
11	0029060	平ネジ /C4X2.6	SCREW	1
12	0070230	平小ネジ /M4X16	SCREW	1
13	0070200	平小ネジ /M4X10	SCREW	1
14	2012520	バネ座金	WASHER	1
15	2122870	スペーサー	SPACER	1
16	2106860	当定規台 (組)	EDGE GUIDE BRACKET ASSY.	1
17	2106870	当定規台	EDGE GUIDE BRACKET	1
18	0050880	六角ボルト /C4X7.5	BOLT	2
19	1670660	座金	WASHER	2
20	2118790	当定規	EDGE GUIDE	1
21	2119460	バインダー (25mm)	BINDER (25mm)	1
22	2118800	バインダー (20mm)	BINDER (20mm)	1
23	0012020	平ネジ /C4X7	SCREW	1
24	1670660	座金	WASHER	1
25	000403-9S0	テープガイド (組)	TAPE DISC ASSY.	1
26	0004060	フェルト	FELT	1
27	0004040	カノコ台	TAPE DISC	1
28	0040120	平ネジ /M4X12	SCREW	1
29	0004070	カラー	COLLAR	1
30	0004080	調節ネジ /M4	SCREW	1
31	0004050	取付棒	BAR	1
32	0004090	取付軸	SHAFT	1
33	0048180	六角ナット /M6	NUT	1
34	000410-SA0	ブラケット	BRACKET	1
35	0049080	木ネジ /4.5	SCREW	3
36	0004130	テープ通し具	TAPE WIRE	1
37	2119490	案内板	GUIDE PLATE	1
38	0070190	平小ネジ /M4X8	SCREW	1
39	XXXXXX	押工 (組)	PRESSER FOOT ASSY.	1
40	277136A0	ホルダー	HOLDER	1
41	0070130	平小ネジ /M3.5X8	SCREW	1
42	2740570	ネジリバネ	SPRING	1
43	0070100	平小ネジ /M3X6	SCREW	1
44	2741060	フィンガーガード	FINGER GUARD	1
45	0070090	平小ネジ /M3X5	SCREW	1
46	212059-B0	ピンネジ	SCREW	1
47	2126680	押工補助板	PRESSER FOOT AUXILIARY PLATE	1
48	0050300	平ネジ /C1X2.3	SCREW	1
49	XXXXXX	押工 (組)	PRESSER FOOT ASSY.	1
50	2771370	ホルダー	HOLDER	1
51	2740520	ネジリバネ	SPRING	1

● xxxxxx はゲージパーツです。
部品番号は 48 ~ 55 頁のゲージパーツ表を
参照してください。

● "xxxxxx" represents the gauge part.
Please refer to the gauge part list (page48-55).

テープ付ケ(Attaching tape)

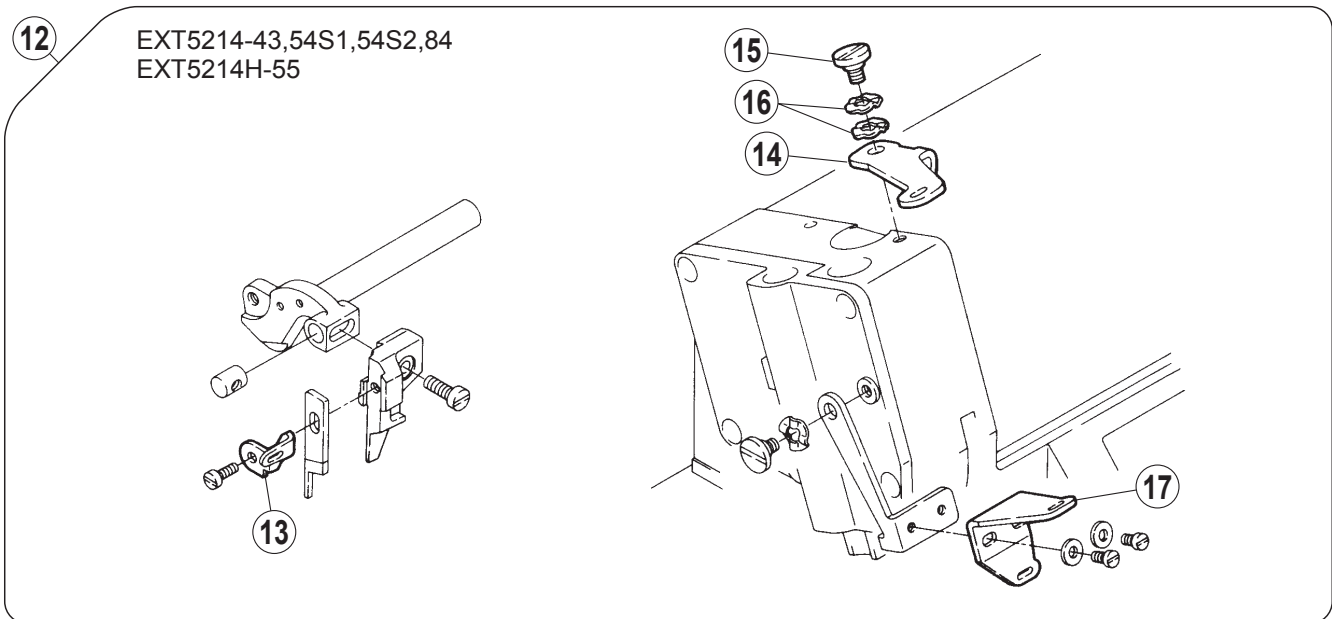
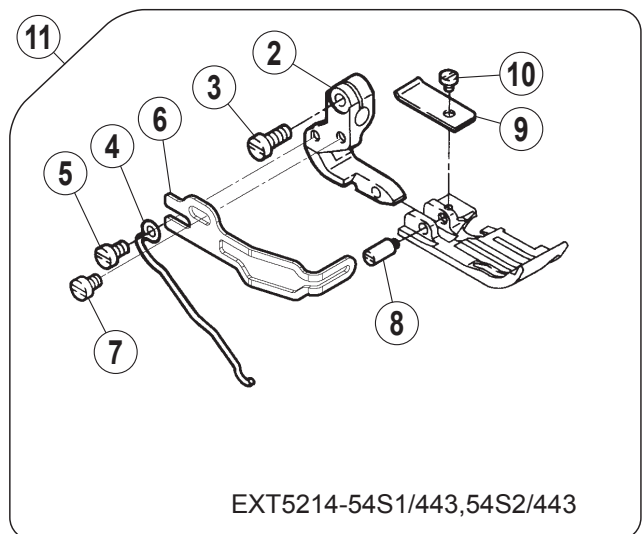
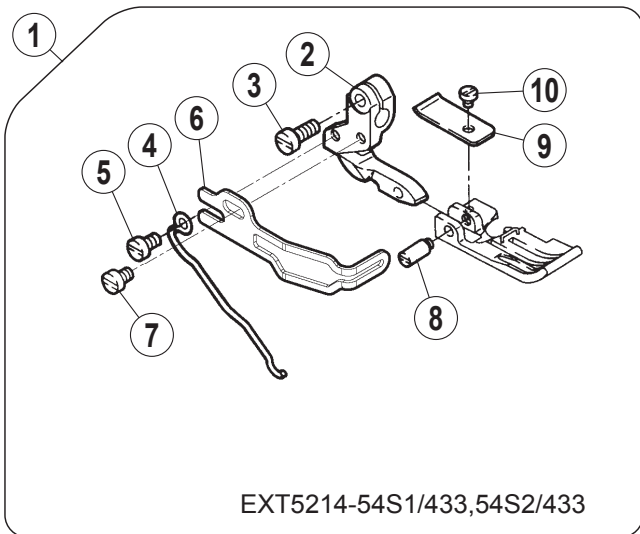

専用部品 (11)

SPECIFIC PARTS(11)

REF.NO.	PART NO.	部品名称	DESCRIPTION	QT.
1	XXXXXX	押工 (組)	PRESSER FOOT ASSY.	1
2	2771370	ホルダー	HOLDER	1
3	0070130	平小ネジ /M3.5X8	SCREW	1
4	2740520	ネジリバネ	SPRING	1
5	0070100	平小ネジ /M3X6	SCREW	1
6	2741060	フィンガーガード	FINGER GUARD	1
7	0070090	平小ネジ /M3X5	SCREW	1
8	212059-B0	ピンネジ	SCREW	1
9	2126680	押工補助板	PRESSER FOOT AUXILIARY PLATE	1
10	0050300	平ネジ /C1X2.3	SCREW	1
11	XXXXXX	押工 (組)	PRESSER FOOT ASSY.	1
12	275542-910	テープ案内 (組)	TAPE GUIDE ASSY.	1
13	2755120	テープ案内	TAPE GUIDE	1
14	2755110	テープ案内	TAPE GUIDE	1
15	0070660	段ネジ /M4	SCREW	1
16	2103070	波板座金	WASHER	2
17	2112670	テープ繰り	TAPE TAKE-UP	1

● xxxxxx はゲージパーツです。
部品番号は 48 ~ 55 頁のゲージパーツ表を
参照してください。

● "xxxxxx" represents the gauge part.
Please refer to the gauge part list (page48-55).

テープ付ケ(Attaching tape)
EXT5214H-55

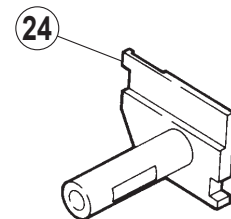
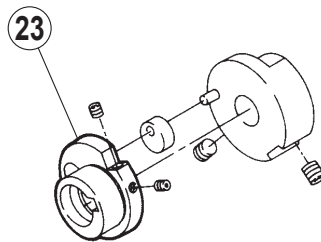
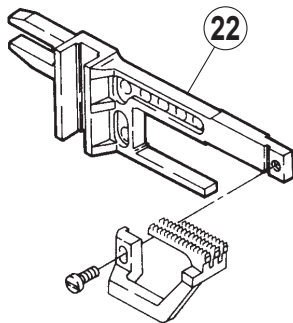
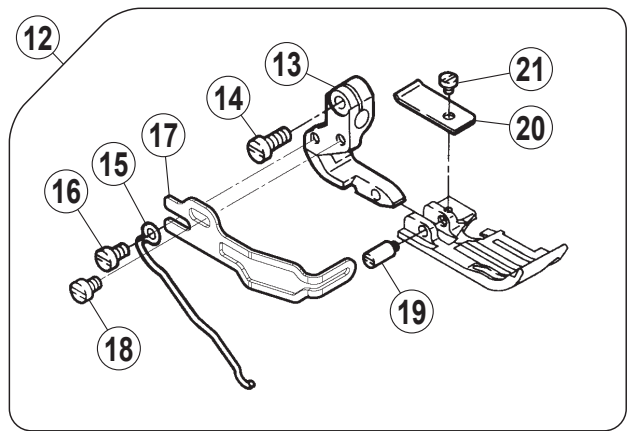
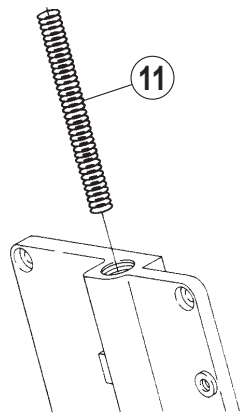
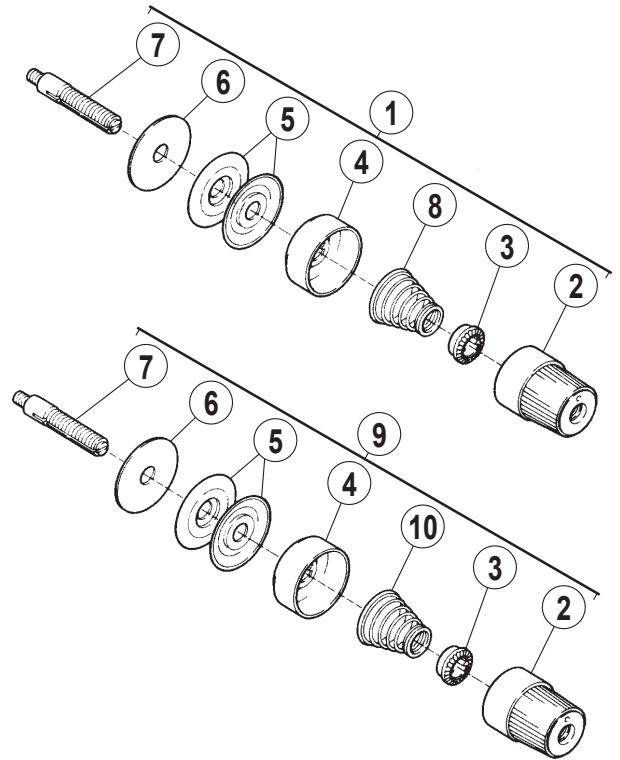
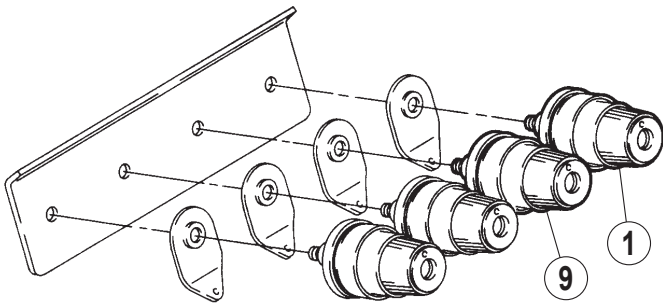

専用部品 (12)

SPECIFIC PARTS(12)

REF.NO.	PART NO.	部品名称	DESCRIPTION	QT.
1	210530A9T0	糸調子 (組)	TENSION SPRING ASSY.	1
2	263543-TA0	ツマミ	KNOB	1
3	2084480	ラatchet	RATCHET	1
4	263544-TA0	受皿	SPRING SHIELD	1
5	2103190	調子皿	TENSION DISC	2
6	2084490	フェルト	FELT	1
7	005082A0	調子棒 /C5	SCREW STUD	1
8	201086A0	圧縮バネ (中)	SPRING(MEDIUM)	1
9	210531-9T0	糸調子 (組)	TENSION SPRING ASSY.	1
10	2010680	圧縮バネ (弱)	SPRING(LIGHT)	1
11	2119410	圧縮バネ	SPRING	1
12	XXXXXX	押工 (組)	PRESSER FOOT ASSY.	1
13	2771370	ホルダー	HOLDER	1
14	0070130	平小ネジ /M3.5X8	SCREW	1
15	2740520	ネジリバネ	SPRING	1
16	0070100	平小ネジ /M3X6	SCREW	1
17	2741060	フィンガーガード	FINGER GUARD	1
18	0070090	平小ネジ /M3X5	SCREW	1
19	212059-B0	ピンネジ	SCREW	1
20	2126680	押工補助板	PRESSER FOOT AUXILIARY PLATE	1
21	0050300	平ネジ /C1X2.3	SCREW	1
22	272528A0	差動送り台	DIFFERENTIAL FEED BAR	1
23	272501A0	エキセン	ECCENTRIC	1
24	273008A0	下メス台	LOWER KNIFE HOLDER	1

● xxxxxx はゲージパーツです。
部品番号は 48 ~ 55 頁のゲージパーツ表を
参照してください。

● "xxxxxx" represents the gauge part.
Please refer to the gauge part list (page48-55).

バックタック(Backlatching)
EXT5214-84, EXT5214H-85

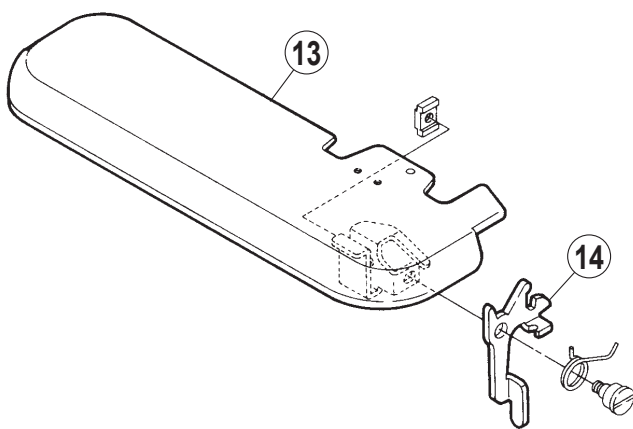
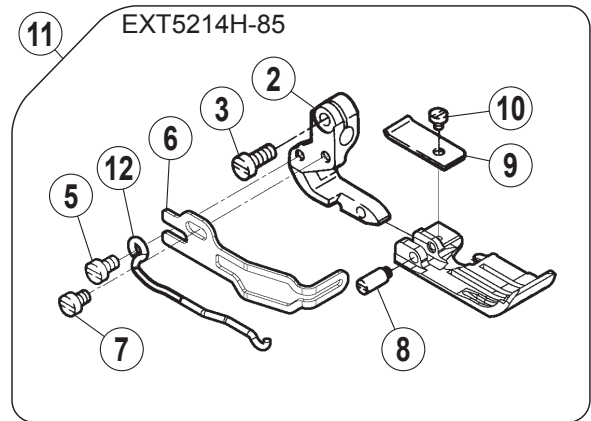
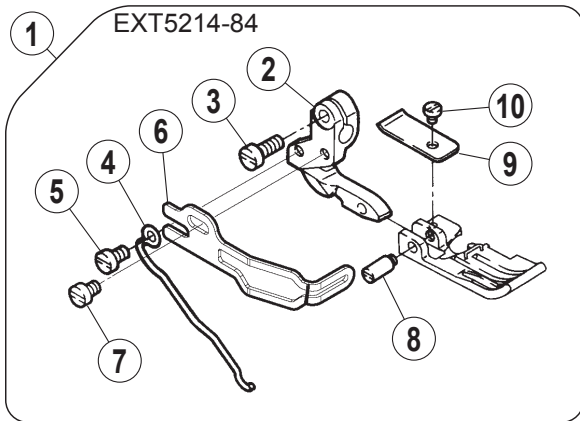

EXT5214-84	15
EXT5214H-85	16

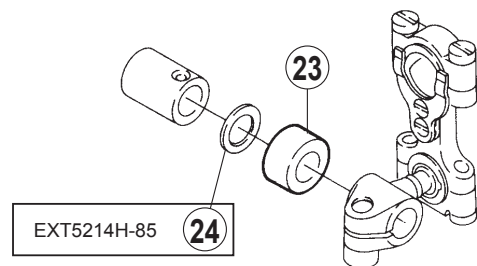
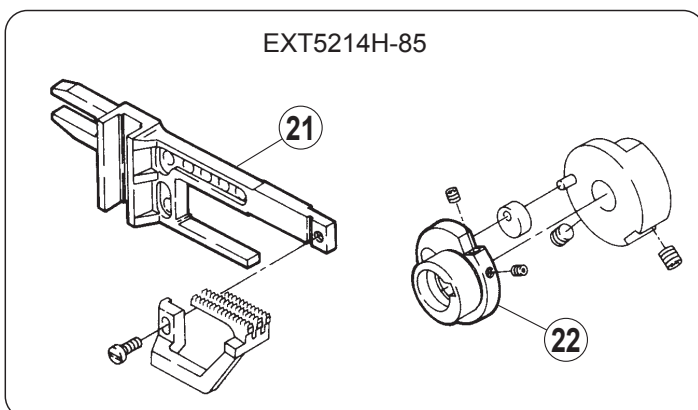
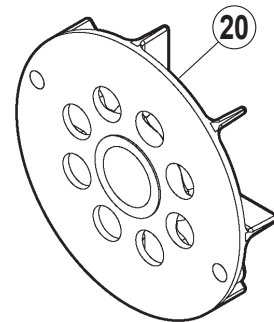
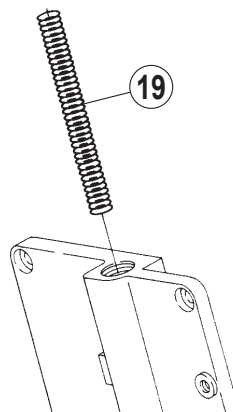
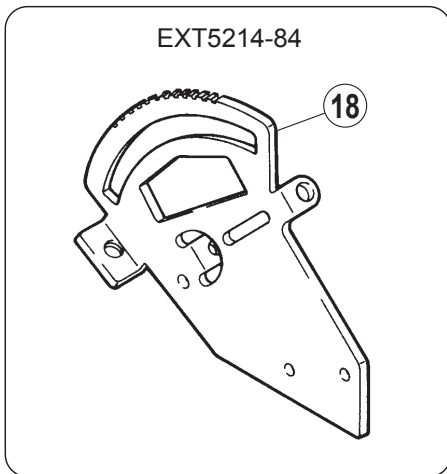
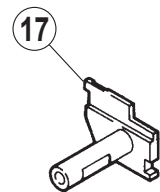
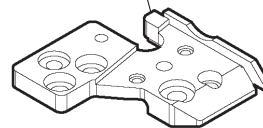

専用部品 (13)

SPECIFIC PARTS(13)

REF.NO.	PART NO.	部品名称	DESCRIPTION	QT.
1	XXXXXX	押工 (組)	PRESSER FOOT ASSY.	1
2	2771370	ホルダー	HOLDER	1
3	0070130	平小ネジ /M3.5X8	SCREW	1
4	2740520	ネジリバネ	SPRING	1
5	0070100	平小ネジ /M3X6	SCREW	1
6	2741060	フィンガーガード	FINGER GUARD	1
7	0070090	平小ネジ /M3X5	SCREW	1
8	212059-B0	ピンネジ	SCREW	1
9	2126680	押工補助板	PRESSER FOOT AUXILIARY PLATE	1
10	0050300	平ネジ /C1X2.3	SCREW	1
11	XXXXXX	押工 (組)	PRESSER FOOT ASSY.	1
12	2741180	ネジリバネ	SPRING	1
13	270037D0	クロスプレート (狭巾)	CLOTHPLATE(NARROW)	1
14	3080930	レバー	LEVER	1
15	308085-D0	取付板 (前)	BRACKET(FRONT)	1
16	308085AD0	取付板 (前)	BRACKET(FRONT)	1
17	273008B0	下メス台	LOWER KNIFE HOLDER	1
18	2765250	調節板	BLADE GUIDE	1
19	2119410	圧縮バネ	SPRING	1
20	270505B1	ファン (組)	FAN ASSY.	1
21	272528A0	差動送り台	DIFFERENTIAL FEED BAR	1
22	272501A0	エキセン	ECCENTRIC	1
23	2403020	スペーサー	SPACER	1
24	2401020	座金	WASHER	1

● xxxxxx はゲージパーツです。
部品番号は 48 ~ 55 頁のゲージパーツ表を
参照してください。

● "xxxxxx" represents the gauge part.
Please refer to the gauge part list (page48-55).

オプション(Option)

EXT5204-02
EXT5214-03,54S1,M03
EXT5214H-55

EXT3215(16)-02,03
EXT3215(16)-A04,B-04
EXT3215(16)H-A05
EXT3244-03,A04

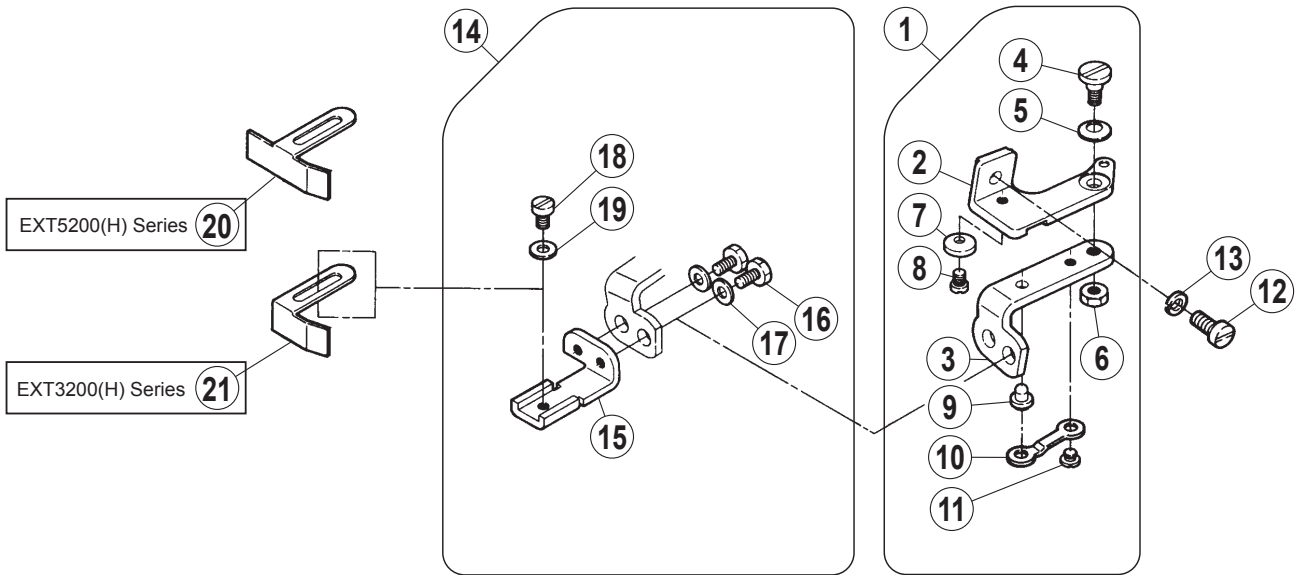

当定規

FABRIC EDGE GUIDE

REF.NO.	PART NO.	部品名称	DESCRIPTION	QT.
1	2106850	定規ブラケット (組)	CLOTH GUIDE BRACKET ASSY.	1
2	2106800	定規ブラケット	CLOTH GUIDE BRACKET	1
3	2106810	ヒンジ / 定規ブラケット	HINGE/EDGE GUIDE BRACKET	1
4	0051840	段ネジ / C5	SCREW	1
5	2011910	皿バネ	SPRING	1
6	0030440	六角ナット / C5	NUT	1
7	2106820	ストッパー	STOPPER	1
8	0050530	平ネジ / C4X4.8	SCREW	1
9	2106830	ピン	PIN	1
10	2106840	板バネ	FLAT SPRING	1
11	0029060	平ネジ / C4X2.6	SCREW	1
12	0070200	平小ネジ / M4X10	SCREW	1
13	2012520	バネ座金	WASHER	1
14	2106860	当定規台 (組)	EDGE GUIDE BRACKET ASSY.	1
15	2106870	当定規台	EDGE GUIDE BRACKET	1
16	0050880	六角ボルト / C4X7.5	BOLT	2
17	1670660	座金	WASHER	2
18	0012020	平ネジ / C4X7	SCREW	1
19	1670660	座金	WASHER	1
20	2046670	当定規	EDGE GUIDE	1
21	201233A0	当定規	EDGE GUIDE	1

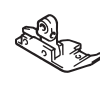
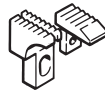

マシン形式	ゲージ		針板	主送り歯 (組)	主送り歯本体	補助送り歯	差動送り歯	上送り歯	押工 (組)	上ルーパー	上スプレッター	下ルーパー	二重環ルーパー
MACHINE TYPE /SPEC	GAUGE		NEEDLE PLATE	MAIN FEED DOG ASSM.	MAIN FEED DOG	AUX.FEED DOG	DIFF.FEED DOG	TOP FEED DOG	PRESSER FOOT ASSM.	UPPER LOOPER	UPPER LOOPER	LOWER LOOPER	CHAINSTITCH LOOPER
	NG	SW											
(16) EXT3215-02/223(K)	3	3	277515R300	277323-160	(277324-160)	(277318-130)	277326-160	2773200	277153-300	2770100 #2	277014A1 #8	2770150	2770180
		4	277513R400				277325-160		277153-400				
		5	277513R500				277153-500						
(16) EXT3215-03/233(K)	3	4	277517R400	277327-160	(277328-160)	(277318-130)	277330-160	2773200	277154-400	277010A0 #5	277014B0 #9	2770150	2770180
		5	277517R500				277154-500						
	5	5	277516R500				277329-160	2773210	277155-500				
		6	277516R600				277155-600						
EXT3216-03/333(K)	5	5	277516R500	277327-160	(277328-160)	(277318-130)	277329-160	2773210	277155-500	2770100 #2	-----	2770150	2770180
(16) EXT3215-03/433(K)	5	5	277516S500	277327-160	(277328-160)	(277318-130)	277329-160	277321-100	277155-500	2770110 #3	2770140 #1	2770150	277018-C0

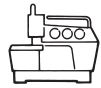

マシン形式	ゲージ		上メス		下メス	オーバー針受		二重環針受		針留	針
			平メス	角メス		前	後	前	後		
	MACHINE TYPE /SPEC	NG	SW	UPPER KNIFE		LOWER KNIFE	OVERLOCK NEEDLE GUARD		CHAINSTITCH NEEDLE GUARD		NEEDLE HOLDER
			FLAT NIFE	ANGLED KNIFE		FRONT	REAR	FRONT	REAR		
(16) EXT3215-02/223(K)	3	3	201121A0	2107550	2022950	2770070	2770040	2770080	2770060	277027-921	DCX27 #11
		4									
		5									
(16) EXT3215-03/233(K)	3	4	201121A0	2107550	2022950	2770070	2770040	2770080	2770060	277027-921	DCX27 #14
		5									
	5	5								277028-920	
		6									
EXT3216-03/333(K)	5	5	201121A0	2107550	2022950	2770070	2770040	2770080	2770060	277028-920	DCX27 #14
(16) EXT3215-03/433(K)	5	5	201121A0	2107550	2022950	2770070	2770040	2770080	2770060	277028-920	DCX27 #16



マシン形式	ゲージ		針板	主送り歯 (組)	主送り歯本体	補助送り歯	差動送り歯	上送り歯	押工 (組)	上ルーパー	上スプレッダー	下ルーパー	二重環ルーパー
MACHINE TYPE /SPEC	GAUGE		NEEDLE PLATE	MAIN FEED DOG ASSM.	MAIN FEED DOG	AUX.FEED DOG	DIFF.FEED DOG	TOP FEED DOG	PRESSER FOOT ASSM.	UPPER LOOPER	UPPER LOOPER	LOWER LOOPER	CHAINSTITCH LOOPER
	NG	SW											
EXT3244-03/333(K)	3 X 2	4	277518R400	277327-160	(277328-160)	(277318-130)	277329-160	2773200	277154A400	277010A0 #5	-----	2770150	2770180
	5 X 2	4	277519R400					2773210	277155A400				
(16) EXT3215-A04/435K	5	5	277524T502	277337-252	(277427-250)	(277428-200)	277339B250	277426-200	277156B500	2770110 #3	2770140 #1	2770150	277018-C0
		6	277524T602						277156B600				
(16) EXT3215-B-04/35(K)	5	5	277524T502	277337-252	(277427-250)	(277428-200)	277339-251	277383A13F0	212056B0	2770110 #3	2770140 #1	2770150	277018-C0
EXT3244-A04/435K	5 X 3	4	277525T402	277337-252	(277427-250)	(277428-200)	277339B250	277426-200	277156C400	2770110 #3	-----	2770150	277018-C0
(16) EXT3215H-A05/535K	5	5	277524T502	277337-252	(277427-250)	(277428-200)	277339B250	277426-200	277156B500	2770170 #11	277014A1 #8	277015A0	277018-C0
		6	277524T602						277156B600				
		7	277524T702						277156B700				



マシン形式	ゲージ		上メス		下メス	オーバー針受		二重環針受		針留	針
			平メス	角メス		前	後	前	後		
MACHINE TYPE /SPEC	GAUGE		UPPER KNIFE		LOWER KNIFE	OVERLOCK NEEDLE GUARD		CHAINSTITCH NEEDLE GUARD		NEEDLE HOLDER	NEEDLE
	NG	SW	FLAT NIFE	ANGLED KNIFE		FRONT	REAR	FRONT	REAR		
EXT3244-03/333(K)	3X2	4	201121A0	2107550	2022950	2770070	2770040	2770080	2770060	277030-920	DCX27 #11
	5X2	4								277031-920	
(16) EXT3215-A04/435K	5	5	-----	2116621	2770091	2770070	2770040	2770080	2770060	277029-920	DCX27 #21
		6								277029-920	
(16) EXT3215-B-04/35(K)	5	5	201121A0	2107550	2770091	2770070	2770040	2770080	2770060	277029-920	DCX27 #21
EXT3244-A04/435K	5 X 3	4	-----	2116621	2770091	2770070	2770040	2770080	2770060	277032-920	DCX27 #21
(16) EXT3215H-A05/535K	5	5	-----	2116621	2770091	2770070	2770040	270080	2770060	277073-920	DCX27 #21
		6									
		7									

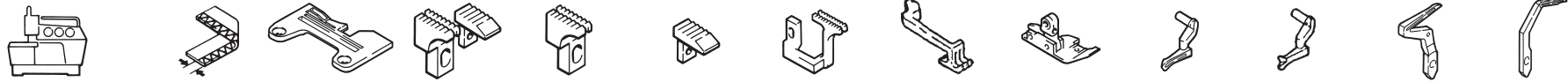

マシン形式	ゲージ		針板	主送り歯(組)	主送り歯本体	補助送り歯	差動送り歯	上送り歯	押工(組)	上ルーパー	上プレッダー	下ルーパー	二重環ルーパー
MACHINE TYPE /SPEC	GAUGE		NEEDLE PLATE	MAIN FEED DOG ASSM.	MAIN FEED DOG	AUX.FEED DOG	DIFF.FEED DOG	TOP FEED DOG	PRESSER FOOT ASSM.	UPPER LOOPER	UPPER LOOPER	LOWER LOOPER	CHAINSTITCH LOOPER
	NG	SW											
(16) EXT3215-42/233(K)	3	4	277517R400	277327-160	(277328-160)	(277318-130)	277330-160	277320A0	277161-400	277010A0 #5	277014B0 #9	2770150	2770180
		5	277517R500						277161-500				
	5	5	277516R500				277329-160	277321A0	277164-500				
		6	277516R600						277164-600				
EXT3216H-45P1/574K	3	5	277573S500	277392A200	(277393A200)	(277318C200)	277394A200	277368B200	277237-500	2770170 #11	-----	277015A0	277018-C0
	5	5	277574S500	277392-200	(277393-200)		277394-200	277399-200	277241-500				
(16) EXT3215-C3P1/233(K)	3	4	277545R400	277327A160	(277328-160)	(277318-130)	277330-160	277320B0	277176-400	277010A0 #5	277014B0 #9	2770150	2770180
		5	277545R500										
	5	5	277546R500				277329-160	277321B1	277177-500				
		6	277546R601										



マシン形式	ゲージ		上メス		下メス	オーバー針受		二重環針受		針留	針				
			平メス	角メス		前	後	前	後						
			UPPER KNIFE			OVERLOCK NEEDLE GUARD		CHAINSTITCH NEEDLE GUARD							
MACHINE TYPE /SPEC	NG	SW	FLAT NIFE	ANGLED KNIFE	LOWER KNIFE	FRONT	REAR	FRONT	REAR	NEEDLE HOLDER	NEEDLE				
(16) EXT3215-42/233(K)	3	4	201121A0	2107550	2022950	2770070	2770040	2770080	2770060	277027-921	DCX27 #14				
		5								277028-920					
	5	5				-----	2107550	2022950	2770070	2770040		2770080	2770060	277054-920	DOX5 #16
		6				277029-920									
EXT3216H-45P1/574K	3	4	201121A0	2107550	2022950	2770070	2770040	2770080	2770060	277027-921	DCX27 #14				
		5								277028-920					
	5	5				-----	2107550	2022950	2770070	2770040		2770080	2770060	277054-920	DOX5 #16
		6				277029-920									



マシン形式	ゲージ		針板	主送り歯 (組)	主送り歯本体	補助送り歯	差動送り歯	上送り歯	押工	上ルーパー	下ルーパー
MACHINE TYPE /SPEC	GAUGE		NEEDLE PLATE	MAIN FEED DOG ASSM.	MAIN FEED DOG	AUX.FEED DOG	DIFF.FEED DOG	TOP FEED DOG	PRESSER FOOT ASSM.	UPPER LOOPER	LOWER LOOPER
	NG	SW									
EXT5204-02/233(K)	-	4	277504R400	277303-16F0	(277304-16F0)	(277318-130)	277305-16F0	2773440	277149-400	2770100 #2	2770150
		5	277504R500						277149-500		
EXT5214-03/333(K)	2	3	277505R300	277303-16F0	(277304-16F0)	(277318-130)	277305-16F0	2773440	277150-300	277010A0 #5	2770150
		4	277505R400						277150-400		
		5	277505R500						277150-500		
EXT5214-M03/333(K)	2	3	277505R300	277303-16F0	(277304-16F0)	(277318-130)	277305-16F0	2773440	277150-300	277010A0 #5	2770340
		4	277505R400						277150-400		
		5	277505R500						277150-500		
EXT5205-12/223(K)	-	4	277500P400	277300-16F0	(277301-16F0)	(277318-130)	277302-16F0	2773580	277181-400	2770100 #2	2770150



マシン形式	ゲージ		上メス		下メス	オーバー針受		針留	針
			平メス	角メス		前	後		
	MACHINE TYPE /SPEC	NG	SW	UPPER KNIFE		LOWER KNIFE	OVERLOCK NEEDLE GUARD		NEEDLE HOLDER
EXT5214-02/233(K)	-	4	201121A0	2107550	2022950	2770050	2770040	179630-920	DCX27 #9
		5							
EXT5214-03/333(K)	2	3	201121A0	2107550	2022950	2770050	2770040	277022-920	DCX27 #9
		4							
		5							
EXT5214-M03/333(K)	2	3	201121A0	2107550	2022950	2770050	2770040	277022-920	DCX27 #9
		4							
		5							
EXT5205-12/223(K)	-	4	201121A0	2107550	2022950	2770050	2770040	179630-920	DCX27 #9



マシン形式 MACHINE TYPE /SPEC	ゲージ GAUGE		針板 NEEDLE PLATE	主送り歯 (組) MAIN FEED DOG ASSM.	主送り歯本体 MAIN FEED DOG	補助送り歯 AUX.FEED DOG	差動送り歯 DIFF.FEED DOG	上送り歯 TOP FEED DOG	押工 PRESSER FOOT ASSM.	上ルーパー UPPER LOOPER	下ルーパー LOWER LOOPER
	NG	SW									
EXT5214-43/333(K)	2	3	277505R300	277303-16F0	(277304-16F0)	(277318-130)	277305-16F0	2773450	277151-300	277010A0 #5	2770150
		4	277505R400						277151-400		
		5	277505R500						277151-500		
EXT5214-54S1/433(K) EXT5214-54S2/433(K)	2	3	277505R300	277303-16F0	(277304-16F0)	(277318-130)	277316-16F0	2773440	277150A300	2770110 #3	2770150
		4	277505R400						277150A400		
		5	277505R500						277150A500		
EXT5214-54S1/443(K) EXT5214-54S2/443(K)	2	3	277507R300	277378-16F0	(277379-16F0)	(277318-130)	277380-16F0	277345A0	277151A300	277011B0 #17	277015B0
		4	277507R400						277151A400		
		5	277507R500						277151A500		
	2.5	3.5	277508R350						277152A350		
		4.5	277508R450						277152A450		



マシン形式 MACHINE TYPE /SPEC	ゲージ GAUGE		上メス UPPER KNIFE		下メス LOWER KNIFE	オーバ針受 OVERLOCK NEEDLE GUARD		針留 NEEDLE HOLDER	針 NEEDLE
			平メス FLAT NIFE	角メス ANGLED KNIFE		前 FRONT	後 REAR		
	NG	SW							
EXT5214-43/333(K)	2	3	201121A0	2107550	2022950	2770050	2770040	277022-920	DCX27 #11
		4							
		5							
EXT5214-54S1/433(K) EXT5214-54S2/433(K)	2	3	201121A0	2107550	2022950	2770050	2770040	277022-920	DCX27 #11
		4							
		5							
EXT5214-54S1/443(K) EXT5214-54S2/443(K)	2	3	201121A0	2107550	2022950	2770050	2770040	277022-920	DCX27 #11
		4							
		5							
	2.5	3.5						277023-920	
4.5									



マシン形式	ゲージ		針板	主送り歯 (組)	主送り歯本体	補助送り歯	差動送り歯	上送り歯	押工	上ルーパー	下ルーパー
MACHINE TYPE /SPEC	GAUGE		NEEDLE PLATE	MAIN FEED DOG ASSM.	MAIN FEED DOG	AUX.FEED DOG	DIFF.FEED DOG	TOP FEED DOG	PRESSER FOOT ASSM.	UPPER LOOPER	LOWER LOOPER
	NG	SW									
EXT5214H-55/545(K)	2.5	3.5	277526S350	277378-25F0	(277379-25F0)	(277318-130)	277380A25F0	277345A20F0	277152A350	2770190 #12	277016A0
		4.5	277526S450						277152A450		
	3	4	277510S400						277152A450		
		5	277510S500						277152A450		
EXT5214-84/433(K)	2	3	277533A300	277340-16F0	(277341-16F0)	(277318-130)	277346-16F0	2773450	277151-300	2770110 #3	2770150
		4	277533A400						277151-400		
EXT5214H-85/535K	2.5	4.5	277527-450	277416-25F0	(277322-25F0)	(277348A160)	277370-25F0	277345-200	277184-450	2770190 #12	277016A0



マシン形式	ゲージ		上メス		下メス	オーバー針受		針留	針						
			平メス	角メス		前	後								
	MACHINE TYPE /SPEC	NG	SW	UPPER KNIFE		LOWER KNIFE	OVERLOCK NEEDLE GUARD		NEEDLE HOLDER	NEEDLE					
EXT5214H-55/545(K)	2.5	3.5	2770000	2116621	2770091	2770050	2770040	277023-920	DOX5 #16						
		4.5						277024-920							
	3	4						201121A0		2107550	2011270	277005A0	2770040	277022-920	DCX27 #11
		5									2022950				
EXT5214-84/433(K)	2	4	201121A0	2107550	2011270	277005A0	2770040	277022-920	DCX27 #11						
EXT5214H-85/535K	2.5	4.5	-----	2107550	2011270	277005A0	2770040	277023-920	DOX5 #14						

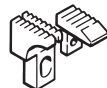

マシン形式 MACHINE TYPE /SPEC	ゲージ GAUGE		針板 NEEDLE PLATE	主送り歯 (組) MAIN FEED DOG ASSM.	主送り歯本体 MAIN FEED DOG	補助送り歯 AUX.FEED DOG	差動送り歯 DIFF.FEED DOG	上送り歯 TOP FEED DOG	押工 PRESSER FOOT ASSM.	上ルーパー UPPER LOOPER	下ルーパー LOWER LOOPER
	NG	SW									
EXT5214-C3P1/333(K)	2	4	277544R400	277303C16F0	(277304-16F0)	(277318-130)	277305-16F0	2773450	277173-400	277010A0 #5	2770150
EXT5214-C3P2/333(K)	2	4	277544R400	277303C16F0	(277304-16F0)	(277318-130)	277305-16F0	2773450	277173-400	277010A0 #5	2770150



マシン形式 MACHINE TYPE /SPEC	ゲージ GAUGE		上メス UPPER KNIFE		下メス LOWER KNIFE	オーバー針受 OVERLOCK NEEDLE GUARD		針留 NEEDLE HOLDER	針 NEEDLE
			平メス FLAT NIFE	角メス ANGLED KNIFE		前 FRONT	後 REAR		
	NG	SW							
EXT5214-C3P1/333(K)	2	4	201121A0	2107550	2022950	2770050	2770040	277022-920	DCX27 #9
EXT5214-C3P2/333(K)	2	4	201121A0	2107550	2022950	2770050	2770040	277022-920	DCX27 #9

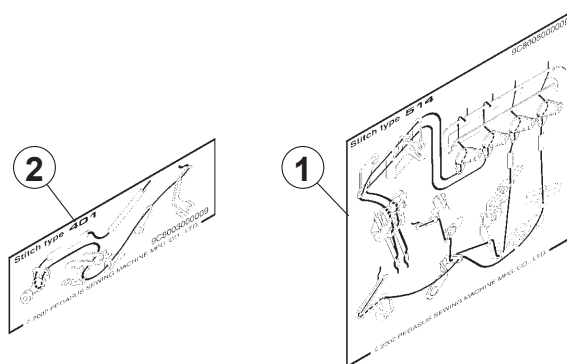

EX3200(H)

REF.NO.	部番 PART NO.	適用機種 Applicable machines
1 2	9A00890 9A00910	EXT3215-02, 03/233, 03/333, 42, C3P1, C3P2
1 2	9A00900 9A00910	EXT3215-03/433
1 2	9A00940 9A00910	EXT3215-A04, B-04 EXT3215H-A05
1 2	9A00850 9A00910	EXT3216-02, 03/233, 03/333, 42, C3P1, C3P2
1 2	9A00860 9A00910	EXT3216-03/433
1 2	9A00950 9A00910	EXT3216-A04, B04, EXT3216H-A05, 45P1, C5P1
1 2	9A00870 9A00910	EXT3244-03
1 2	9A00960 9A00910	EXT3244-A04

EX5200(H)

REF.NO.	部番 PART NO.	適用機種 Applicable machines
1	9A00800	EXT5204-02, EXT5205-12
1	9A00820	EXT5214-03, M03, 43, C3P1, C3P2
1	9A00930	EXT5214-54S1, 54S2, 84 EXT5214H-55, 85

インデックス

INDEX

PART NO.	PAGE	REF.NO.	PART NO.	PAGE	REF.NO.	PART NO.	PAGE	REF.NO.	PART NO.	PAGE	REF.NO.	PART NO.	PAGE	REF.NO.
000403-9S0	37	38	005082A0	25	7	0070820	35	8	209229-B0	21	19	2124360	37	28
000403-9S0	39	25	005082A0	27	7	0070990	31	31	209229-B0	33	16	2124980	21	21
0004040	37	40	005082A0	33	27	0070990	37	31	2094080	17	7	2124980	33	18
0004040	39	27	005082A0	43	7	0071430	9	10	2094090	17	8	2126010	31	5
0004050	37	44	0050880	29	16	0071430	35	29	2094100	17	10	2126010	37	5
0004050	39	31	0050880	39	18	0071540	9	4	2101220	23	26	2126030	31	12
0004060	37	39	0050880	47	16	0071640	31	35	2101220	27	30	2126030	37	12
0004060	39	26	0051040	31	8	0071640	37	35	2101220	33	39	2126580	31	18
0004070	37	42	0051040	37	8	0071700	35	6	210201-SD0	17	18	212659A0	37	13
0004070	39	29	0051570	29	21	0071931	15	14	2103070	41	16	2126600	31	16
0004080	37	43	0051840	29	4	0072060	3	9	2103190	21	31	2126600	37	16
0004080	39	30	0051840	39	4	0072070	3	10	2103190	23	5	2126680	21	9
0004090	37	45	0051840	47	4	0072070	31	42	2103190	25	5	2126680	29	38
0004090	39	32	0052990	29	29	0072070	37	52	2103190	27	5	2126680	33	9
000410-SA0	37	47	0053800	31	6	0072330	3	6	2103190	33	25	2126680	39	47
000410-SA0	39	34	0053800	37	6	0072670	33	35	2103190	43	5	2126680	41	9
0004130	39	36	0070070	3	25	0073550	9	6	210530A9T0	21	27	2126680	43	20
0011960	31	15	0070070	33	34	1371420	29	24	210530A9T0	23	1	2126680	45	9
0011960	37	15	0070080	23	18	1379060	35	14	210530A9T0	25	1	212978-910	17	5
0012020	39	23	0070080	25	18	1379060	35	17	210530A9T0	27	1	2129810	17	6
0012020	47	18	0070080	27	22	1670660	29	17	210530A9T0	33	21	213218A920	15	10
0012060	29	26	0070080	31	23	1670660	39	19	210530A9T0	43	1	2400390	3	4
0012340	31	11	0070080	33	37	1670660	39	24	210531-9T0	21	35	2400390	3	31
0012340	37	11	0070080	37	23	1670660	47	17	210531-9T0	23	9	2400420	7	23
0024300	29	22	0070090	21	7	1670660	47	19	210531-9T0	25	9	2401020	23	31
0029050	29	23	0070090	21	18	179201-150	7	22	210531-9T0	27	9	2401020	25	31
0029060	29	11	0070090	23	16	179320-050	3	20	210531-9T0	33	29	2401020	33	40
0029060	39	11	0070090	25	16	179765-150	31	37	210531-9T0	43	9	2401020	45	24
0029060	47	11	0070090	27	20	179765-150	37	37	2106800	29	2	2401040	31	36
0029210	27	15	0070090	29	41	2005550	7	28	2106800	39	2	2401040	35	28
0030440	29	6	0070090	33	7	2010220	7	10	2106800	47	2	2401040	37	36
0030440	39	6	0070090	39	45	2010680	21	36	2106810	29	3	2401100	5	11
0030440	47	6	0070090	41	7	2010680	23	10	2106810	39	3	2401480	3	21
0031530	21	23	0070090	43	18	2010680	25	10	2106810	47	3	2401480	5	29
0031530	33	20	0070090	45	7	2010680	27	10	2106820	29	7	2401520	19	2
0040120	37	41	0070100	21	5	2010680	33	30	2106820	39	7	2402910	3	39
0040120	39	28	0070100	21	16	2010680	43	10	2106820	47	7	2402920	13	1
0045000	7	21	0070100	29	36	201086A0	21	34	2106830	29	9	2402940	3	28
0045010	15	2	0070100	33	5	201086A0	23	8	2106830	31	9	2402960	7	3
0045110	9	2	0070100	39	43	201086A0	25	8	2106830	37	9	2402970	5	4
0045140	5	2	0070100	41	5	201086A0	27	8	2106830	39	9	240298-20	5	3
0045140	5	25	0070100	43	16	201086A0	33	28	2106830	47	9	2403020	25	26
0045140	35	26	0070100	45	5	201086A0	43	8	2106840	29	10	2403020	45	23
0045210	7	4	0070110	17	11	2011910	29	5	2106840	31	10	2403220	7	25
0045220	17	4	0070120	17	9	2011910	39	5	2106840	37	10	2403280	17	15
0045310	15	11	0070120	35	15	2011910	47	5	2106840	39	10	2403320	7	19
0045310	23	30	0070120	35	18	201211C910	29	27	2106840	47	10	2403471	23	21
0045310	25	30	0070130	21	3	201233A0	47	21	2106850	29	1	2403471	25	21
0045330	3	12	0070130	21	14	2012520	29	13	2106850	39	1	2403471	27	26
0045330	3	44	0070130	23	13	2012520	31	4	2106850	47	1	2403510	5	28
0045330	5	8	0070130	25	13	2012520	37	4	2106860	39	16	2403680	3	19
0045330	5	14	0070130	27	18	2012520	39	14	2106860	47	14	2403710	19	12
0045330	5	23	0070130	29	34	2012520	47	13	2106870	39	17	2405410	23	27
0045340	3	15	0070130	33	3	2016290	5	16	2106870	47	15	2405410	25	27
0045340	7	2	0070130	33	32	2021760	3	18	2106890	29	20	2405410	27	31
0045430	3	33	0070130	39	41	2024330	31	32	2106900	29	15	2405420	3	2
0045430	3	35	0070130	41	3	2024330	37	32	2106910	29	14	2405420	3	29
0045430	5	19	0070130	43	14	2025770	5	10	2106920	29	25	2405590	7	26
0045430	5	21	0070130	45	3	2041850	17	13	2109300	9	11	263543-TA0	21	28
0045430	31	21	0070140	3	37	2041850	19	11	2109300	15	9	263543-TA0	23	2
0045430	37	21	0070180	15	8	2046670	47	20	2109550	31	14	263543-TA0	25	2
0045540	13	2	0070180	19	6	2048880	31	7	2109550	37	14	263543-TA0	27	2
0045540	35	4	0070190	35	20	2048880	35	23	2112670	41	17	263543-TA0	33	22
0045740	35	3	0070190	39	38	2048880	37	7	2113010	7	16	263543-TA0	43	2
0048000	17	12	007019A0	7	8	2050610	23	32	2116180	17	2	263544-TA0	21	30
0048060	31	33	0070200	29	12	2050610	25	32	2118790	39	20	263544-TA0	23	4
0048060	37	33	0070200	31	3	205113A0	17	16	2118800	39	22	263544-TA0	25	4
0048180	37	46	0070200	37	3	2053610	29	18	2119170	27	14	263544-TA0	27	4
0048180	39	33	0070200	39	13	2058350	29	28	2119410	21	26	263544-TA0	33	24
0048340	35	24	0070200	47	12	2064310	17	19	2119410	31	38	263544-TA0	43	4
0049080	37	48	007021A0	17	20	2073580	3	22	2119410	43	11	270037D0	45	13
0049080	39	35	007021A0	31	26	2073580	5	27	2119410	45	19	2700670	9	3
0050300	21	10	007021A0	31	40	2082350	3	16	2119460	39	21	2700680	9	1
0050300	29	39	007021A0	37	26	2082350	5	12	2119490	39	37	270068A0	23	19
0050300	33	10	007021A0	37	50	2084480	21	29	212059-B0	21	8	270068A0	25	19
0050300	39	48	007022A0	31	30	2084480	23	3	212059-B0	27	12	270069-911	9	5
0050300	41	10	007022A0	37	30	2084480	25	3	212059-B0	29	37	2700790	9	7
0050300	43	21	0070230	39	12	2084480	27	3	212059-B0	33	8	2700810	9	9
0050300	45	10	007024A0	5	6	2084480	33	23	212059-B0	39	46	270083A9U0	9	12
0050530	29	8	0070260	7	18	2084480	43	3	212059-B0	41	8	270083D9U0	23	22
0050530	39	8	0070430	35	21	2084490	21	32	212059-B0	43	19	270083D9U0	25	22
0050530	47	8	0070440	3	27	2084490	23	6	212059-B0	45	8	270083D9U0	27	27
0050570	29	19	0070440	7	13	2084490	25	6	2120600	27	16	270138-910	35	11
0050600	17	3	0070560	3	3	2084490	27	6	2120610	27	13	270140-910	35	9
0050770	31	17	0070560	3	30	2084490	33	26	2121520	19	7	2701420	35	12
0050770	31	19	0070590	7	15	2084490	43	6	2122870	39	15	270505B1	45	20
0050770	37	17	0070660	9	8	208958-B0	23	14	2123200	19	14	270512B1	23	34
0050770	37	19	0070660	41	15	208958-B0	25	14	2124350	31	27	270512B1	35	10
005082A0	21	33	0070770	7	12	209229AB0	21	20	2124350	37	27	271003A0	13	3
005082A0	23	7	0070820	35	2	209229AB0	33	17	2124360	31	28	271003B0	5	9

インデックス

INDEX

PART.NO.	PAGE	REF.NO.	PART.NO.	PAGE	REF.NO.	PART.NO.	PAGE	REF.NO.	PART.NO.	PAGE	REF.NO.	PART.NO.	PAGE	REF.NO.
271018C910	13	4	275030A0	23	24	2771390	33	13						
271019AC0	13	6	275030A0	25	24	303312A0	29	30						
2710200	13	5	275030A0	27	25	3033130	29	31						
2710370	35	5	275030A0	33	38	308085ADO	45	16						
2710380	35	1	275044A0	11	7	308085-D0	45	15						
2710390	35	7	2750510	11	1	3080930	45	14						
272501A0	43	23	275052A0	11	5	9A30020	17	21						
272501A0	45	22	2750570	27	23									
272528A0	43	22	275106A0	11	3									
272528A0	45	21	2751230	23	20									
272538A0	7	24	2751230	27	24									
272539A0	7	27	275123A0	25	20									
273001A920	3	43	2755110	41	14									
273002A920	3	42	2755120	41	13									
273008A0	43	24	2755220	31	34									
273008B0	45	17	2755220	37	34									
273009A0	23	25	2755230	31	29									
273009A0	25	25	2755230	37	29									
273009A0	27	29	275532-910	31	1									
274011-910	9	13	2755330	31	2									
274021-92B0	27	17	2755340	31	20									
274025A0	27	21	2755340	37	20									
2740280	21	22	2755350	31	22									
2740340	23	15	2755350	37	22									
2740340	25	15	2755360	31	25									
2740350	3	38	2755360	37	25									
2740360	3	40	2755370	31	24									
2740370	3	41	2755370	37	24									
2740410	15	13	2755390	31	13									
274042-920	15	1	275542-910	41	12									
2740430	15	3	2755610	35	19									
2740440	15	4	2755620	35	25									
274045-910	15	5	2755630	35	22									
274048-910	15	12	2755640	35	27									
2740510	21	4	2755650	35	16									
2740510	29	35	275566-910	37	1									
2740520	33	4	2755670	37	2									
2740520	39	51	2755680	35	13									
2740520	41	4	2755690	37	18									
2740520	43	15	276500-920	5	1									
2740520	45	4	276501A920	5	5									
2740530	21	15	276502-920	5	7									
2740530	33	14	2765030	7	6									
2740540	15	7	276504-910	5	13									
2740550	15	6	2765070	5	15									
2740560	33	19	2765080	5	17									
2740570	39	42	2765090	5	18									
2740660	27	19	2765100	5	20									
2740980	33	36	276511-920	5	22									
2741060	21	6	2765120	5	26									
2741060	29	40	276513-920	7	1									
2741060	33	6	2765140	7	9									
2741060	39	44	2765150	7	5									
2741060	41	6	2765160	7	7									
2741060	43	17	2765170	7	11									
2741060	45	6	2765180	7	17									
274106A0	21	17	2765190	7	14									
274106A0	33	15	276520-920	3	14									
2741070	23	17	2765210	31	39									
2741070	25	17	2765210	37	49									
2741080	33	33	2765220	31	41									
2741120	23	28	2765220	37	51									
2741120	25	28	2765240	7	20									
2741130	23	33	2765250	45	18									
2741130	25	33	2765260	3	7									
274114-920	23	29	2765270	3	17									
274114-920	25	29	276528-910	3	26									
2741150	23	35	2765310	3	32									
2741150	25	34	2765320	3	34									
274116-910	23	23	2765330	3	8									
274116-910	25	23	2765340	3	1									
274116-910	27	28	2765350	3	5									
2741180	45	12	276536-920	3	11									
2745070	19	1	276537-920	5	24									
2745280	17	17	2765380	3	13									
274532-910	17	14	2765390	3	24									
2745390	17	22	2765400	3	23									
274546-910	17	1	2771300	23	12									
2745490	19	3	2771300	25	12									
2745500	19	4	2771360	21	2									
274551A910	19	8	2771360	29	33									
274552A910	19	9	277136A0	39	40									
2745560	19	10	2771370	33	2									
2745590	19	5	2771370	39	50									
2745920	19	13	2771370	41	2									
2750080	21	24	2771370	43	13									
2750090	21	25	2771370	45	2									
275016A0	11	2	2771380	21	12									
275017A0	11	4	2771380	33	12									
275027A0	11	6	2771390	21	13									

ペガサスミシン製造株式会社

本社 〒 553-0002 大阪市福島区鷺洲 5-7-2 TEL (06)6458-4739
FAX (06)6454-8785

PEGASUS SEWING MACHINE MFG. CO., LTD.

5-7-2, Sagisu, Fukushima-ku, Osaka 553-0002, Japan. Phone : (06)6458-4739
Telefax: (06)6454-8785

Cat. No. 96250  August 2003

© 1993 PEGASUS SEWING MACHINE MFG. CO., LTD.

このパーツカタログに記載されている内容は、改良のため予告なく変更することがあります。

The description in this PARTS CATALOG is subject to change without prior notice.