

For the professional user

Operating Instructions

Für den professionellen Anwender

Betriebsanleitung

Class: 141-23EV
Klasse:

Model: 10
Ausführung:

Machine number:
Maschinen-Nr.:

Dated:
Stand:

The sign of quality



You find the Strobel trademark on every Strobel machine leaving our works. And with good reason. This symbol is a guarantee of the high quality of our products. Quality which creates trust – trust in our technology, our service and, not least of all, in our good name.

Im Zeichen der Qualität

Sie finden die Strobel-Schutzmarke auf jeder Strobel-Maschine, die unser Werk verlässt. Und das aus gutem Grund. Denn dieses Zeichen garantiert Ihnen die hohe Qualität unserer Produkte. Qualität, die Vertrauen schafft – in unsere Technik, unseren Service und nicht zuletzt in unseren guten Namen.

Strobel clients know that they can expect a particularly high standard of performance from our company and our machines. Now you have settled for one of our products. For us this is a source of encouragement and of obligation to Justify your trust.

If you wish to profit from the performance and efficiency of your Strobel machine as long as possible, exact handling and thorough care is necessary. For this reason we kindly request that you read the operating instructions closely. It provides all the information you need for trouble free operation.

And if you do happen to need a spare part the enclosed spare parts list gives a complete overview. It is clearly classified according to components so that you can find the required part quickly and easily. In order to avoid errors we request you to quote machine class, machine number and part number completely on your spare part order.

We wish you lots of success in your work with your new Strobel machine.

Garantiekarte/ Warranty Sheet

Maschinenklasse/ Machine Class: _____

Serien-Nr./ Serial No: _____

Auftrags-Nr./ Order Confirmation No: _____

Lieferdatum/ Delivery Date: _____

Rechnungs-Nr./ Invoice No: _____

Rechnungsdatum/ Invoice Date: _____

Beanstandung/ Complaint: _____

Datum/ Date

Unterschrift/ Signature

Bitte nicht vom Kunden ausfüllen! To be filled out by Strobel:

| | Datum | Bemerkung |
|-------|-------|-----------|
| EXA: | | |
| ETA: | | |
| PROD: | | |
| EXA: | | |
| BH: | | |

Unterseite/underside

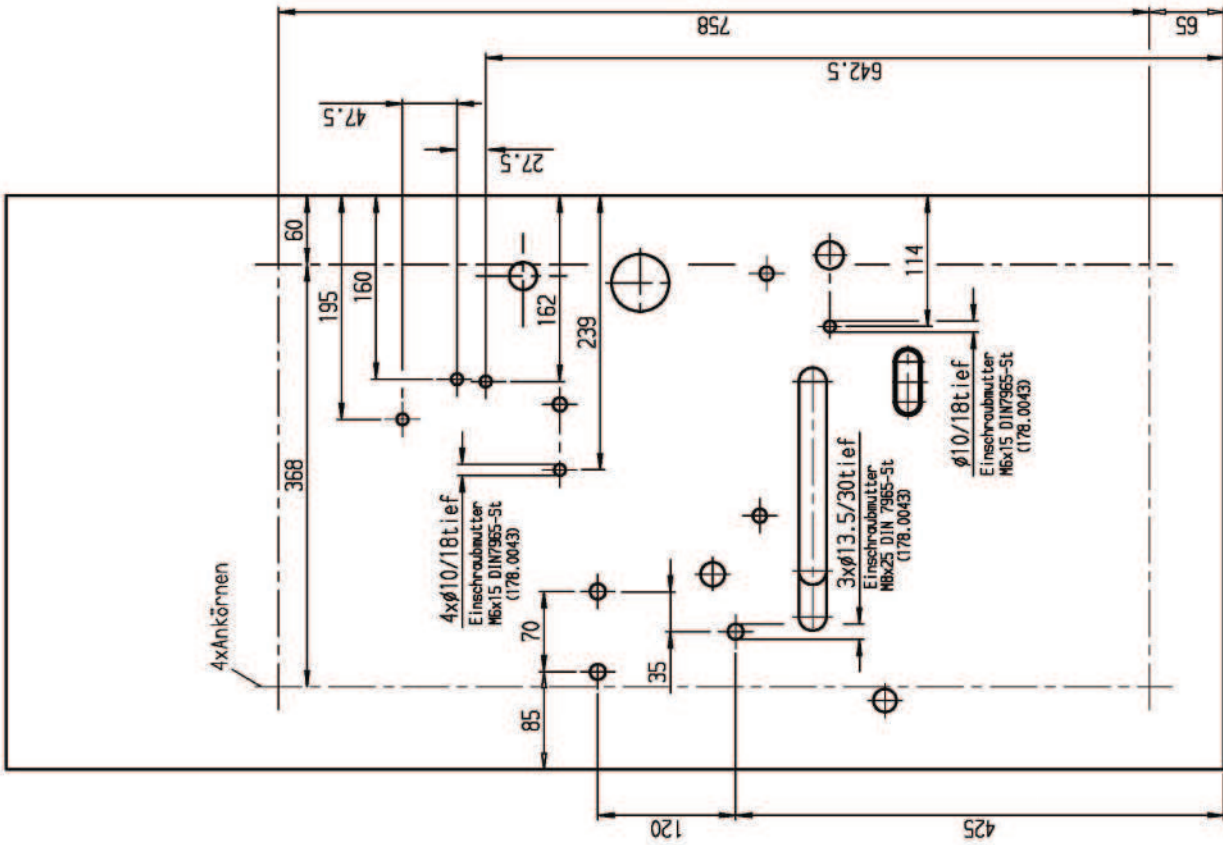

Oberseite/upper side

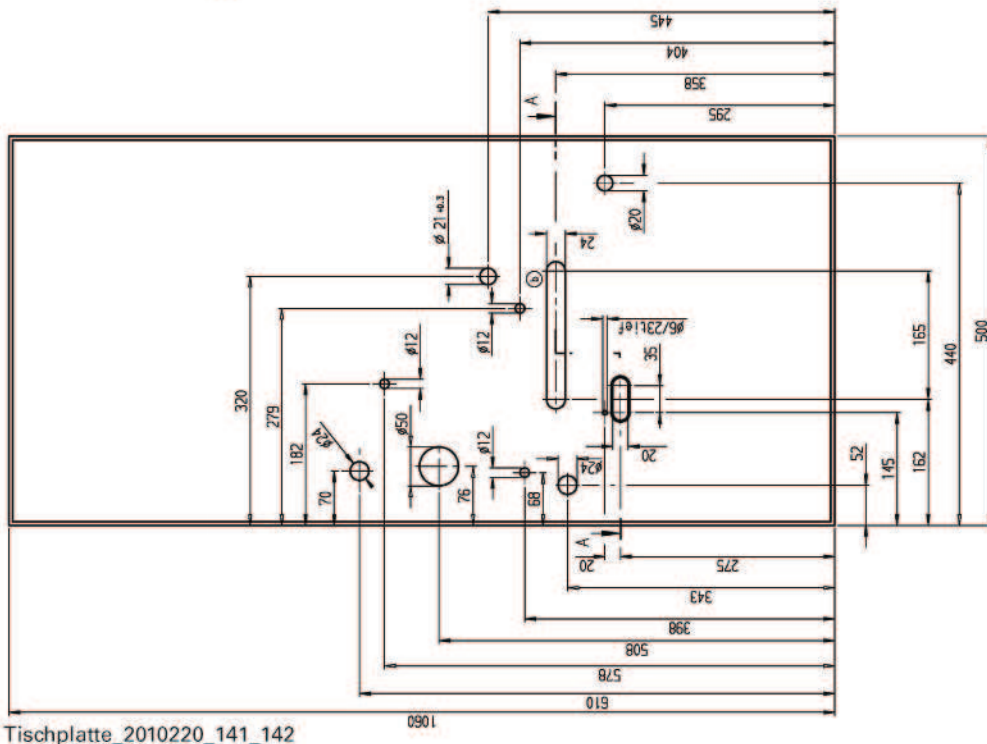

Tischplatte_2010220_141_142

Operating Instructions STROBEL Class 141-23EV

Contents

| | | |
|---------|---|----|
| 1 | General notes on safety | 5 |
| 2 | General | 7 |
| 2.1 | Operating instructions..... | 7 |
| 2.2 | Class identification, serial number and orientation of the machine..... | 7 |
| 2.3 | Range of application and intended use | 7 |
| 2.4 | Technical data | 8 |
| 3 | Installation and putting into service | 9 |
| 3.1 | Unpacking the machine | 9 |
| 3.2 | Installation | 9 |
| 3.3 | Sense of rotation (Fig. 2)..... | 11 |
| 3.4 | Motor drive via V-belts | 11 |
| 3.4.1 | Tensioning the V-belt | 11 |
| 3.4.2 | Positions of the machine..... | 12 |
| 3.5 | First lubrication | 14 |
| 4 | Instructions for use | 15 |
| 4.1 | Needles and threads | 15 |
| 4.1.1 | Working instructions..... | 15 |
| 4.1.1.1 | Working with gathering device | 15 |
| 4.1.1.2 | Working for Cosy shoes (Fig. 10) | 18 |
| 4.1.1.3 | “String-lasting” method (Fig. 11) | 19 |
| 4.2 | Inserting the needle (Fig. 13)..... | 20 |
| 4.3 | Threading and thread course | 21 |
| 4.4 | Thread tension (Fig. 1) | 21 |
| 4.5 | Setting the stitch length (Fig. 14)..... | 22 |
| 5 | Machine maintenance | 23 |
| 5.1 | Oil drain pipe | 24 |
| 6 | Variable sewing tools | 27 |
| 7 | Optional extras | 31 |
| 7.1 | Sewing lights | 31 |

Subject to change without prior notice

1 General notes on safety

The non-compliance with the following notes on safety can lead to bodily injuries or to damages of the machine.

1. The machine must only be operated by persons familiar with the relevant operating instructions and who have been instructed accordingly.
2. Before commissioning also read the notes on safety and the operating instructions of the sewing drive manufacturer.
3. The machine must only be operated according to its designation and not without the appropriate guards; all explicit safety regulations must also be observed.
4. For threading, for changing the reels, for exchanging sewing tools such as needles, grippers, stitch plate, transport devices, if necessary cutter and cutting block, for cleaning, when leaving the workplace and for maintenance work, switch off main switch or pull mains plug. With a mechanically operated coupling motor without activation lock, wait until the motor has stopped.
5. General maintenance work must only be carried out by appropriately instructed persons in accordance with the operating instructions.
6. Repair, modification and maintenance work must only be carried out by qualified staff or by appropriately instructed persons.
7. During maintenance and repair work at pneumatic devices, the machine must be disconnected from the pneumatic supply network. Exceptions are only admissible during adjusting work and function test by appropriately instructed qualified staff.
8. Work at the electrical equipment must only be carried out by qualified staff.
9. Work at parts and devices under voltage is not allowed. Exceptions are regulated by the regulation EN50110 (DIN VDE0105).
10. Modification or alteration at the machine must only be undertaken under consideration of all explicit safety regulations.
11. Only spare parts released by us for use are to be used during repairs.
12. The commissioning of the upper part is prohibited until it has been determined that the entire sewing unit complies with the regulations of the EC guidelines.

13. Warning notes in the operating instructions of the machine, which point out special points of danger, are marked at the appropriate positions with the safety symbol.



Warning notes in the operating instructions of the machine which point out special dangers of injury for operating or qualified staff, are marked at the appropriate positions with the symbol



It is essential that you observe and follow these notes as well as the generally valid safety regulations.

2 General

2.1 Operating instructions

Any person involved in the installation, operation, maintenance and repair of the machine must have read and understood the operating instructions and mainly the safety instructions before starting the machine. Please open the illustrations at the beginning of these operating instructions, so you can follow the illustrations step by step while reading the instructions.

2.2 Class identification, serial number and orientation of the machine

The operating side of the machine is the basis for descriptions referring to sides. The class type is attached top left on the housing, the machine and model number (after the dash) is attached bottom left on the housing.

These data are also shown on the front page of the operation instructions.

2.3 Range of application and intended use

Class 141-23EV

Single Thread Overseaming Machine with gathering device for sewing insoles to uppers of heavy weight textile and leather shoes up to a total thickness of 7 mm.

With appropriate optional features also suitable for “string lasting” and California processing.

2.4 Technical data

| | | |
|---|-----------------------------|----------------------------|
| Number of stitches: | Max mechanically admissible | 2300 min ⁻¹ |
| | Recommended rated speed | 1800 min ⁻¹ |
| Machine pulley diameter | | dw 80 |
| V-belt profile | | 10 x 6 mm |
| Stitch length | | 3 – 6.5 mm adjustable |
| Kind of stitch | | Single Thread Overseam |
| Needle system | | 134 |
| Needle size | | 140 |
| Recommended thread | | twisted polyester filament |
| Recommended thread size | | 40 - 20 |
| Stitch type | | 501 |
| Kind of feed | | rear cup drive |
| Pneumatic connection | | 10 bar |
| Operating pressure | | 5 – 6 bar |
| Required space | | 0.6 x 1.06 m |
| Noise: | | |
| Average noise level at a speed of n = 1800 min ⁻¹ : | | LpAm 73 dB |
| | Noise test according to | DIN 45635-48-1 KL3 |

3 Installation and putting into service

3.1 Unpacking the machine

Strobel machines are supplied either as complete units with head, stand and motor, or head with motor only, or the head only.

Due to the high weight and to avoid damages during transport, complete units are packed in several smaller cartons.

Machine head and motor are removed from the stand. Reel stand, rods, oil and other accessories are packed into the stand packing. Make sure that all accessories have been unpacked before throwing away any packing material.

3.2 Installation



ATTENTION!

Danger of bodily injuries or finger bruises through pulling in of garments or hairs!
The machine may not be operated without belt guards for head and motor.

Caution: Screw oil drain pipe 133.0764 to the lid 112.0085 before setting the top part on the table top. (See chapter “5.1 Oil drain pipe”)

If the frame is not delivered by us as well, but rather the machine set on a different frame, then the table top needs to be prepared as can be seen in the table-top diagram.



ATTENTION!

Before putting the machine into service make sure that the electrical connecting data on the motor's name plate, your electric network, and all other connecting values, e. g. for the air, correspond to the data shown on the machine and the operating instructions.

All rust protection agents, such as Vaseline and similar agents have to be wiped off carefully from the sewing tools before putting the machine into service.

Fig. 1

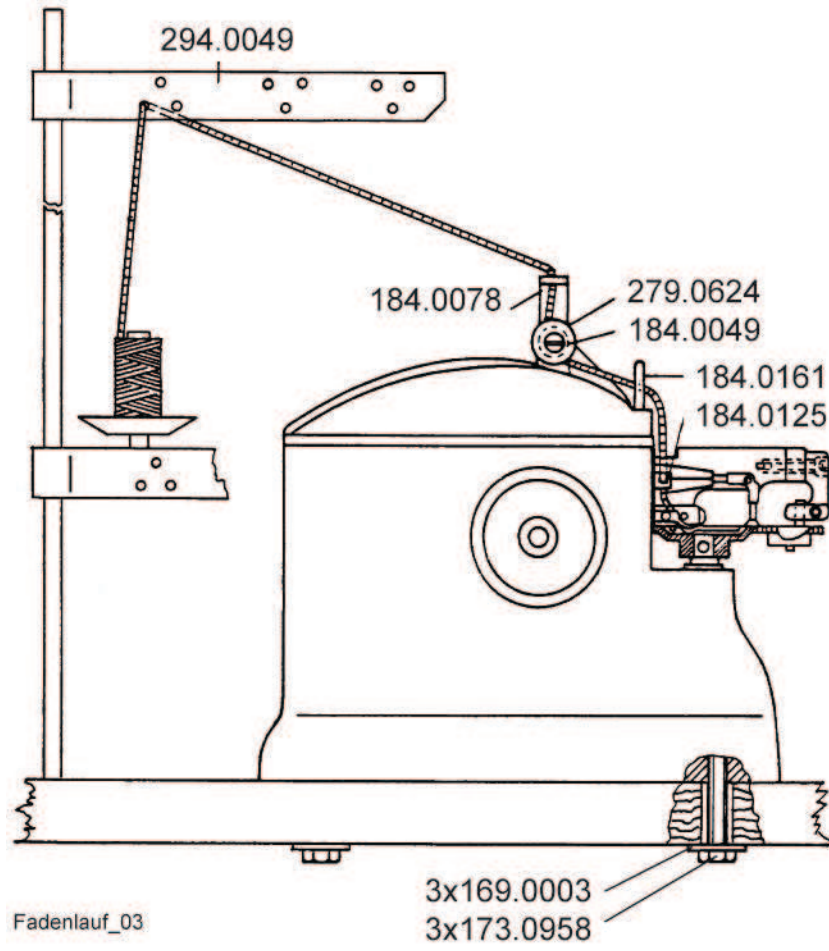

3.3 Sense of rotation (Fig. 2)

The correct sense of rotation of the hand wheel is clockwise in line of vision on the hand wheel.

Fig. 2

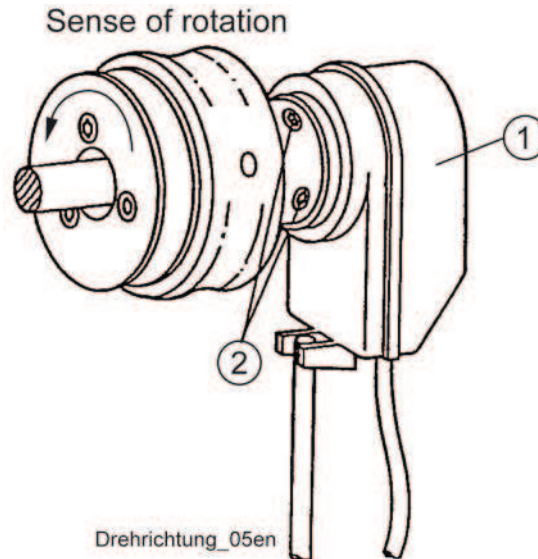

3.4 Motor drive via V-belts

3.4.1 Tensioning the V-belt



CAUTION! Danger of injury!

When checking the belt tension, switch off the machine at the mains. Do not operate the machine without the belt guard. Otherwise there is a DANGER of crushing fingers, of injuries to the body and of pulling in parts of clothing.

The tensioning of the V-belt is carried out by swivelling the motor underneath the table plate after releasing the retaining nut with SW 24.

The V-belt must not be tensioned too much, especially with the stop motor. You should be able to depress it with light thumb pressure by about 2 cm.

Too little V-belt tensioning can impair the positioning of the machine and therefore impair the function sequence.

3.4.2 Positions of the machine



CAUTION! Danger of injury!

Danger of crushing fingers and needle through stitching as well as pulling in of parts of clothing.
Keep fingers and hands away from moving parts when setting the position generator and checking the positions with switched-on machine.

General:

Stop motors require a position generator, which takes the mechanical setting of the machine from the main screw and transmits this to the control of the motor. (Fig. 2)

The correct position of the position generator to the flange is marked with a spot of paint.

To adjust or to remove, release the two clamping screws (2), Fig. 2. tighten these firmly prior to commissioning.

Machine with or without hold-back device:

The machine requires two needle positions and, depending on the sewing drive, possibly also a reference position.

Reference position (if required, i.e. sewing drive DC1500-ST220A (Fig. 3)):

The reference position must be set in such a way, that the point of the needle in the direction of the insertion stitch closes with the outer table edge.

Fig. 3

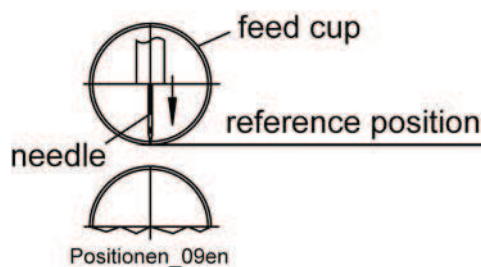

Needle position (with stop outside the seam with pedal position “2”
Fig. 4)):

The needle position must be set in such a way, that the distance between the outer table edge in the stitch direction and the tip of the needle is about 10 mm.

Needle position is position 2 at the sewing drive.

Fig. 4

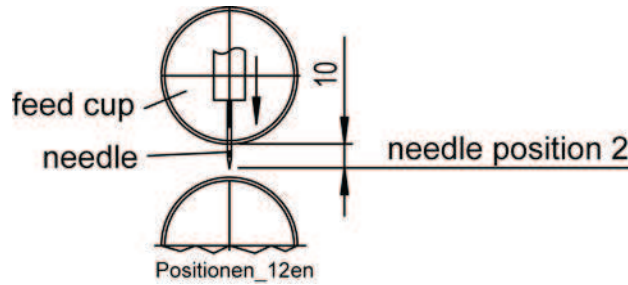

Needle position (with stop in and outside the seam with pedal position “0” (Fig. 5)):

The needle position must be set in such a way, that the distance between the tip of the needle in the stitch direction and outer table edge is about 4 mm.

Needle position is position 1 at the sewing drive.

Fig. 5

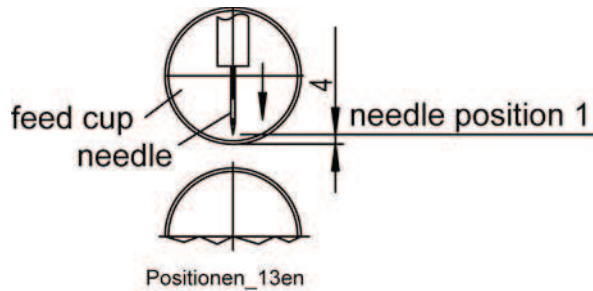

3.5 First lubrication

Remove outer and inner machine cover and pour in original STROBEL oil supplied with the machine from above.

To take off the inner cover first pull out the small oil pipe in the oil rising pipe of the pump. (Fig. 6)

The special STROBEL oil (viscosity 46 c St) supplied with the machine should always be used.

The required oil quantity is 0.5 liter. It is recommended to change the oil after approx. six month operation. (See also chapter "5 Machine maintenance")

Fig. 6

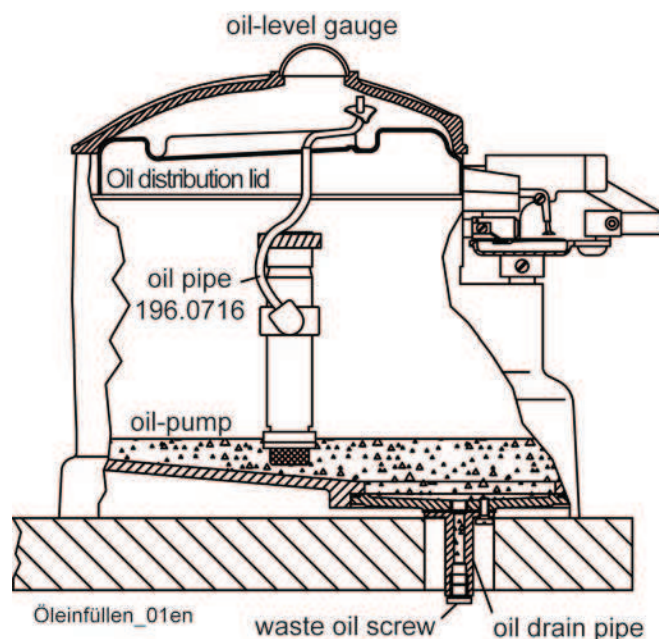

The oiling points are automatically lubricated, therefore no maintenance required.

When remounting the inner cover make sure that the lower part of the oil pipe is pushed into the oil rising pipe of the pump. (Fig. 6). **Otherwise the automatic lubrication does not work and the machine will be heavily damaged through blocking of the shafts in the bearings, etc.**

Therefore follow the instructions carefully and, after filling the machine with new oil, operate the machine for a short while and control the working of the automatic lubrication through the oil inspection glass in the outer cover.

4 Instructions for use

4.1 Needles and threads

(See chart, chapter “2.4 Technical data”)

The needle size to be used depends on the material to be sewn and on the thread respectively. Needle type to be used is 134.

When joining fused parts it may happen that the needle eye conglutinates, which may affect the loop formation.

Thicker and harder material requires thicker needles.



G u a r a n t e e d r e m a r k !

This machine has been set and sewn off with **genuine Strobel needles**.

No guarantee can be granted if the settings are modified for using different needle types.

4.1.1 Working instructions

Class 141-23 is used for attaching the insole to the upper, up to a total thickness of 7 mm.

4.1.1.1 Working with gathering device

By class 141-23 the insole is sewn to the upper. The gathering device facilitates the distribution of extra fullness of the upper at the toe on Vulcano and light weight leather shoes. A flat seam is obtained which is completely covered when vulkanizing the shoe in a press subsequently.

The gathering device (EV) is operated by means of the left treadle. By pushing it forwards the lever with guide 186.0195 (Fig. 7 and Fig. 9) of the gathering device is swivelled between the feed cups by means of the rod and the deflection lever. By heeling the treadle, the gathering device returns to its initial position. Lift feed cups by means of knee lever before swivelling the gathering device.

By using the gathering device a uniform distribution of excess material is obtained. The operator actuates the gathering device on certain spots market at insole and upper. After acquiring some experience, such marks are not necessary any more. (Fig. 8).

Machines used with gathering device should be equipped with a stop motor for two needle positions, to simplify handling and to increase output.

First position = front needle position

Second position = rear needle position

The first needle position is important when swivelling guide 186.0195, to keep the shoe in a certain position when lifting the cups; this first position is also necessary for threading.

Fig. 7

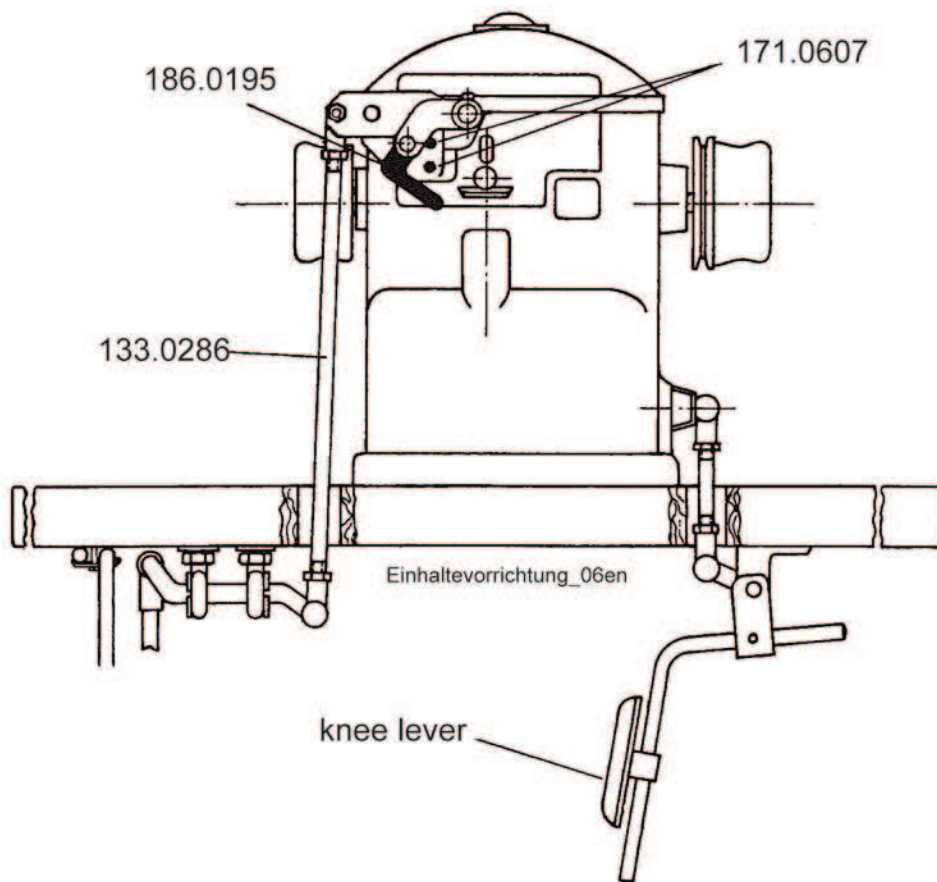

Fig. 8

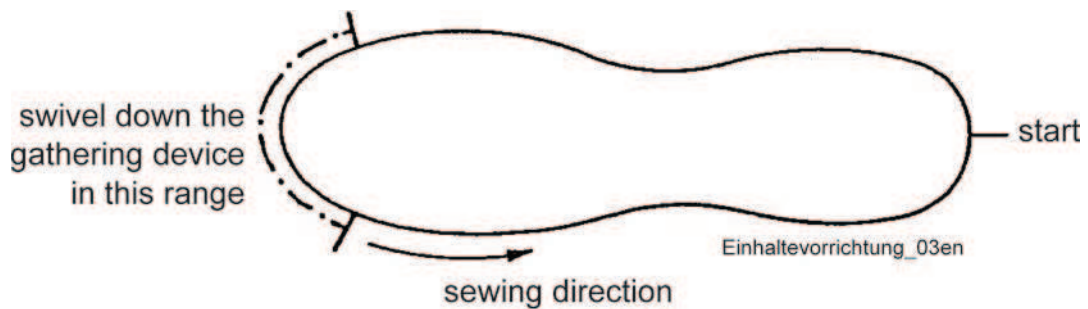
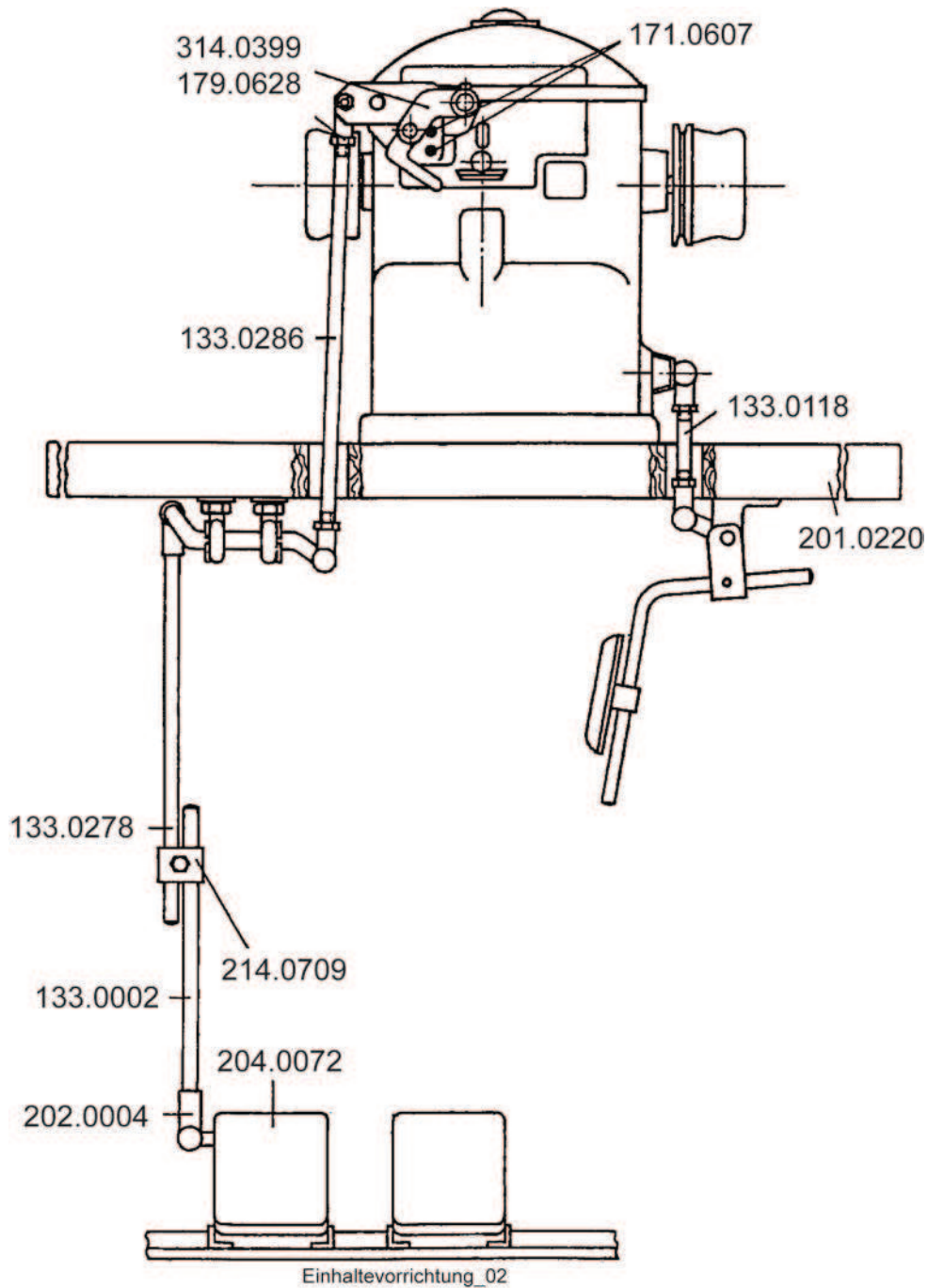

Fig. 9



The second needle position is necessary for inserting and removing the material.

The machine is operated as follows (see also "Fig. 9")

- | | | | |
|----|------------------|---|------------------|
| 1. | right treadle | : | motor |
| 2. | left treadle | : | gathering device |
| 3. | right knee lever | : | lifting |
| 4. | left knee lever | : | thread trimmer |

4.1.1.2 Working for Cosy shoes (Fig. 10)

Class 141-23 is suitable for attaching the insole made of canvas or similar material to the upper of reversed Cosy shoes (see drawing). First attach the insole from A to B around the heel. Then push the felt insert with felt or cork heel in the open shoe and go on attaching the insole to the upper, now from B to A.

Fig. 10

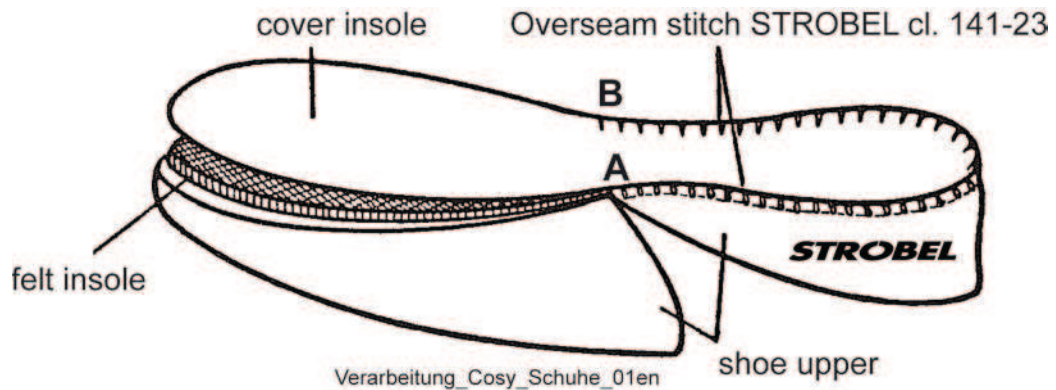

This operating requires a certain stiffness of the upper, i. e. that the outsole (chrome leather or similar material) and its carton reinforcement had been attached to the upper before.

After having finished the sewing process on Class 141-23, the shoe is softened by steam and then turned, so that the outsole made of leather or similar material is on the outside and the insole on the inside of the slipper.

4.1.1.3 “String-lasting” method (Fig. 11)

Class 141-23 is used for Vulcano shoes manufactured according to the “String lasting” method, i. e. for sewing a cord to the upper for tensing the material on the last later.

Guide cord through eye of reel stand, then through eye 184.0024 at cover, and to boring at material guide 186.0203.

Fig. 11

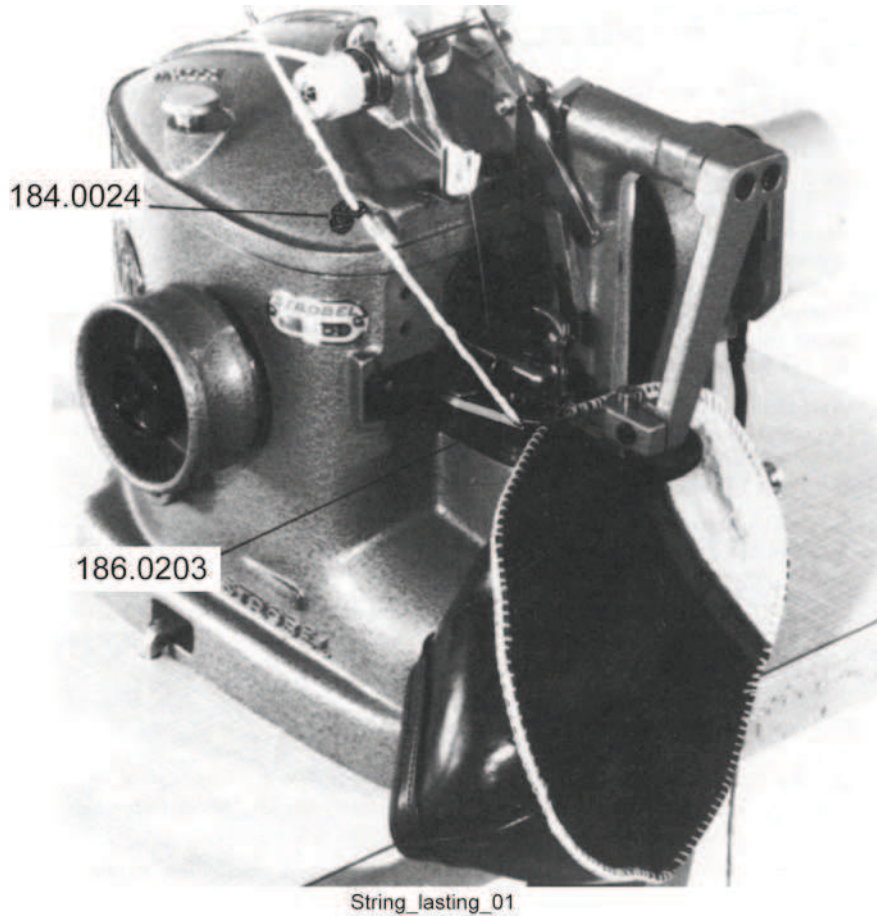

4.2 Inserting the needle (Fig. 13)



ATTENTION!

Switch off machine electrically and confirm that the machine is really in standstill position by operating the treadle for the motor control before changing the needle. Otherwise danger of finger bruises and needle throughstitches.

Introduce the needle with its horizontal groove pointing downwards, push it to the rear until it strikes against needle stop 134.0220 (Fig. 12). Then the needle is clamped by means of screw 171.0407 (Fig. 13).

Fig. 12

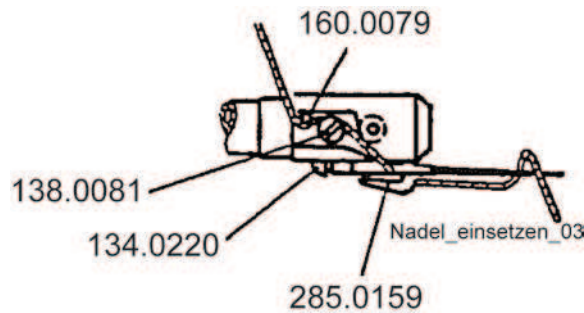
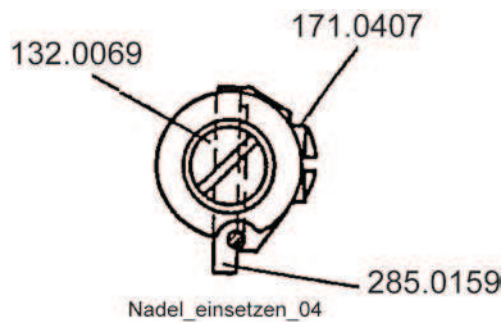

Fig. 13



4.3 Threading and thread course

| | |
|---|-------------------|
|  | ATTENTION! |
| Switch off machine electrically and confirm that the machine is really in standstill position by operating the treadle for the motor control before changing the needle. Otherwise danger of finger bruises and needle throughstitches. | |

Fig. 1 and Fig. 12 show the right threading.

After putting the bobbin on the supporting bolt of the reel stand, the thread is guided through the eye of thread guiding arm. (Fig. 1)

Further pass it through thread guide 184.0078 (depending on thread and material through 1 to 3 holes) and thread tension discs 184.0049 to thread guide 184.0161 and through thread eye 184.0125.

Then guide the thread beneath pin 160.0079 at needle bar head and put it round thread clamping screw 138.0081. After hooking it into needle set plate 285.0138 from the left to the right, the thread is passed through the eye of the needle from below (Fig. 12).

Thread guide 184.0078 should always be in a vertical position to obtain a large looping angle between the thread tension discs.

4.4 Thread tension (Fig. 1)

Depending on quality, nature and thickness of the thread, thread tension is set by means of tension nut 279.0624. A thick and strong thread requires tight tension.

When lifting the cup support arm the thread tension discs are separated by means of lifting disc 246.0143, so that the thread is pulled easily and the material can be withdrawn. Angle 116.0235 has to be set in a way that the full effect of the thread tension discs is maintained, even when sewing thicker material.

4.5 Setting the stitch length (Fig. 14)



ATTENTION!

Switch off machine electrically and make sure that it is really in standstill position by holding the trade for the motor control before setting the stitch length. Otherwise danger off finger bruises and needle thoughstitches.

As shown in Fig. 7, the stitch length can be adjusted by means of stitch adjusting knob 344.0089 in the inside of the left handwheel, which is equipped with pointer 124.0080 showing through the "S" slot in the handwheel.

The handwheel has a scale according to which pointer 124.0080 has to be set.

The figures of this scale do not represent a certain stitch length in mm, but serve as reference figures only. However, low figures mean smaller stitch length and viceversa.

Fig. 14

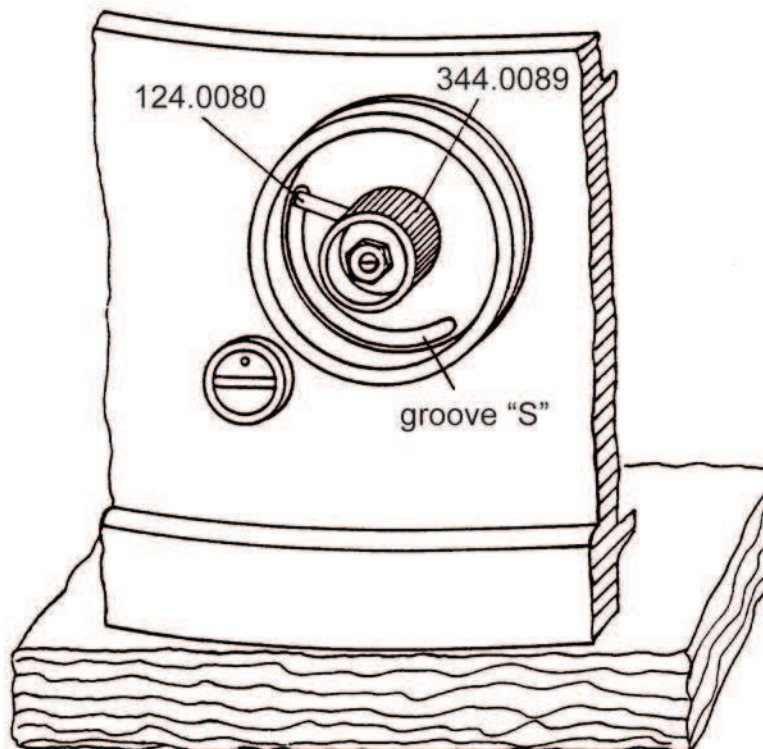

Stichlängeinstellung_04en

5 Machine maintenance



Attention!

Switch off machine electrically and confirm that the machine is really in standstill position by operating the treadle for the motor control.

Otherwise danger of finger bruises and needle throughstitches.

The machine is maintenancefree due to automatic lubrication (see chapter “3.5 First lubrication”), only once a week dirt and hairs should be removed from oil drain hole “D” to allow the oil coming from the needle bar to drain off. Also oil splashing protector “C” should be cleaned (remove small cover at looper shaft), to avoid that the oil is soaked up by the dirt and thus spoiling the material.

Once a week oil drain hole “D” should be cleaned to allow the oil coming from the needle bar to drain off (Fig. 15). Also oil splashing protector “C” should be cleaned (remove small cover at looper shaft), to avoid that the oil is soaked up by the dirt and thus spoiling the material.

Checking the oil level:

Make sure that there is always **sufficient** oil in the machine to enable the pump to submerge in the oil and to always bring the oil upwards.

A plastic receptacle with a capacity of exactly 1 liter is supplied with the machine. After having filled the machine with one liter oil, the oil pump’s suction piece is submerged in the oil.

Oil quantity and cleanness should be checked every six to twelve month maximum.

If the oil is still clean enough, the oil quantity can be checked using the plastic receptacle. Drain the oil into this receptacle and re-fill it into the machine if the oil quantity is still correct. It is recommended to order a second oil container to complete the oil quantity to one liter, if necessary.

The first oil change should be realized after about six month operation.

Fig. 15

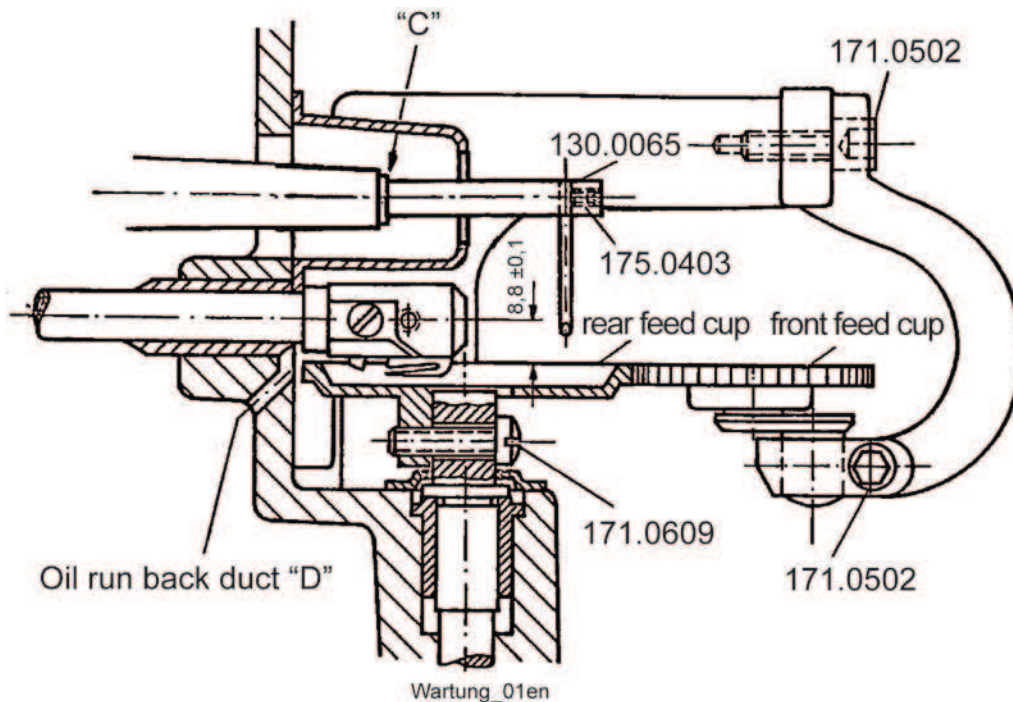

5.1 Oil drain pipe

To facilitate machine maintenance, at the machine body or at the lower cover respectively there is oil drain pipe 133.0764 going through the table top, thus enabling to drain the oil without removing the machine head.

The oil drain pipe 133.0764 is sealed by means of seal ring 193.0530 and screw 173.0772 (Fig. 17).

For machine assembly and for shipment the screw borings in cover 112.0085 are sealed by means of ring 193.0530 and screw 193.0772 as well as three rings 190.0010 and screws 172.0521 each (Fig. 16).

Before mounting head to the table top screws 193.0772 and 172.0521 with the seal rings have to be removed and the oil drain pipe with sealing washer 190.0178 has to be mounted and sealed (Fig. 17).

To drain the waste oil put a receptacle under the pipe and remove screw 193.0772 only. After having drained the oil screw on screw 193.0772 and seal it.

Dispose of old oil properly!



ATTENTION! Danger!

Observe safety instructions and operating instructions before starting any maintenance or repair works. Failure to do so can result in serious bodily injuries.

After having drained the oil rinse the machine thoroughly with petroleum and then refill with new oil.

When removing the inner cover, also oil pipe 196.0716 for the automatic lubrication which comes from the oil pump through the inner cover with oil, is removed (Fig. 6)

When re-mounting the inner cover please observe that the lower end of the main oil pipe is put into the conical opening of the oil outlet piece of the oil pump (Fig. 6). **If you fail to do so the automatic lubrication does not work and the machine may be damaged seriously by jamming of the shafts in the bearings.**

Therefore these instructions should be observed carefully and after refilling new oil make sure the automatic lubrication works properly by briefly operating the machine and controlling the class at the outer cover.

Before operating the machine make sure that all protection devices (e. g. cover, belt-guard, etc.) are effective and that all screws are tightened.

Fig. 16

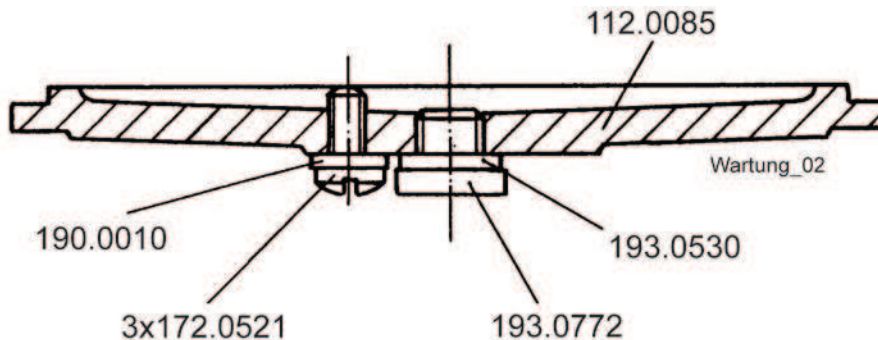
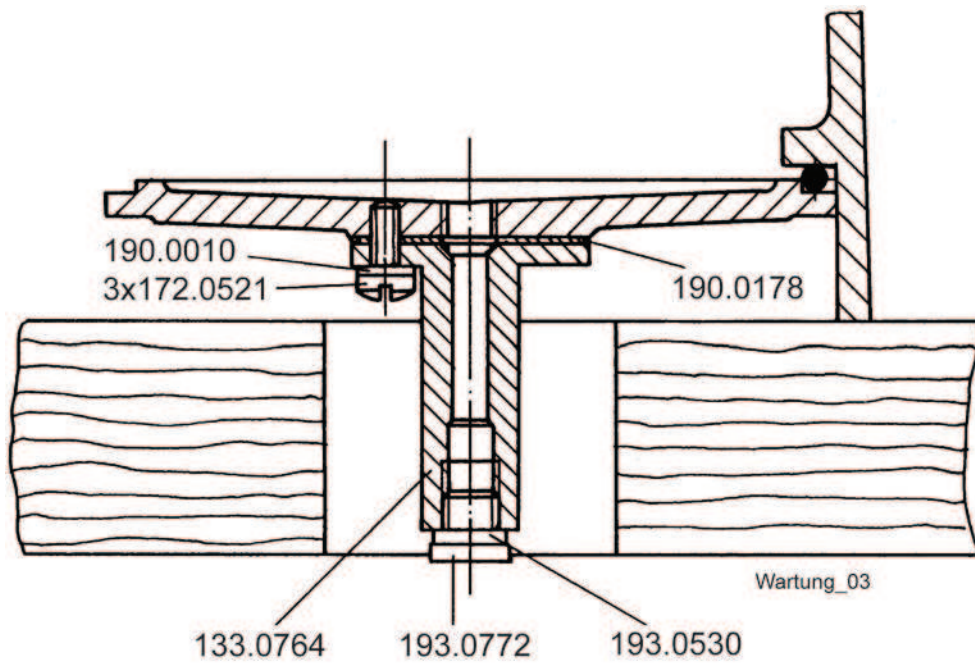

Fig. 17



6 **Variable sewing tools**



Attention!

Switch off machine electrically and confirm that the machine is really in standstill position by operating the treadle for the motor control.

Otherwise danger of finger bruises and needle throughstitches.

The following charts show all feed cups, front cups and material guides available.

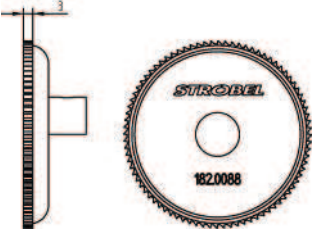
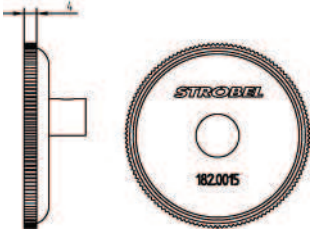
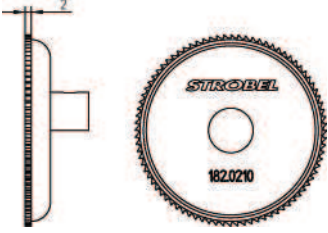
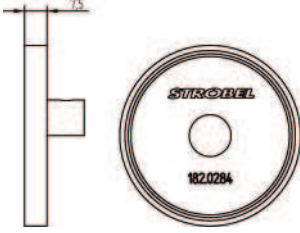
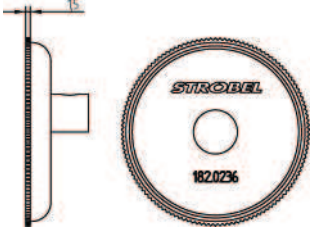
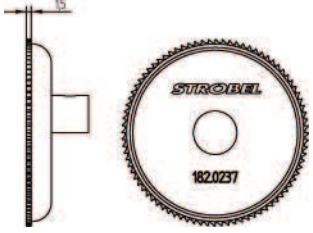

Class 141-23EV – Feed cups

| | |
|---|--|
| <p style="text-align: center;">Standard</p>  <p>182.0088 Feed cup Ø60, pitch 2,25</p> | <p style="text-align: center;">Optional extra</p>  <p>182.0015 Feed cup Ø60, pitch 1,5</p> |
| <p style="text-align: center;">Optional extra</p>  <p>182.0210 Feed cup Ø60, pitch 2,25</p> | <p style="text-align: center;">Optional extra for delicate material with risk of marking</p>  <p>182.0284 Feed cup Ø60,5, rubber coated</p> |
| <p style="text-align: center;">Optional extra for California shoes</p>  <p>182.0236 Feed cup Ø60, pitch 1,5</p> | <p style="text-align: center;">Optional extra for California shoes</p>  <p>182.0237 Feed cup Ø60, pitch 2,25</p> |
| | |

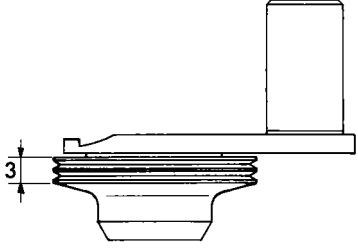
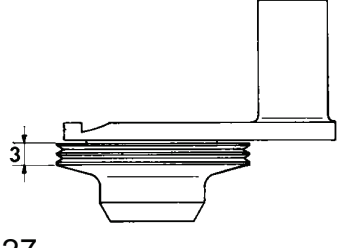
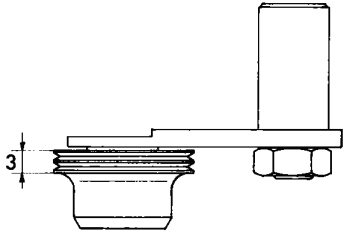
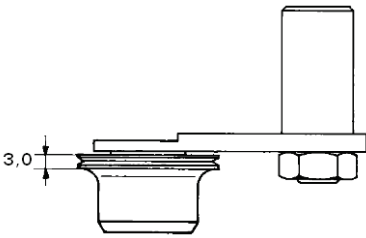
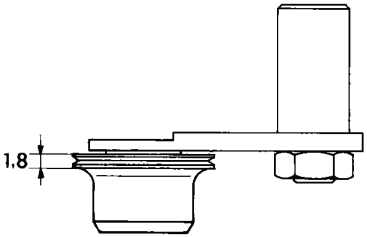
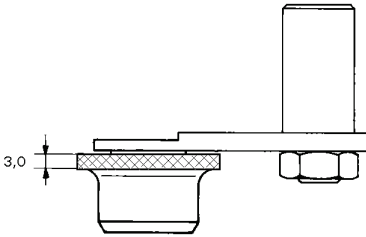
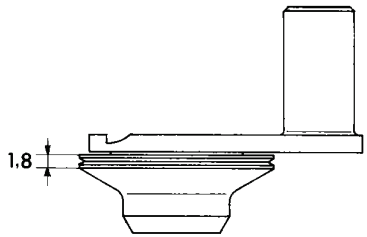
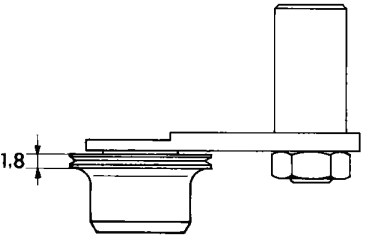
Class 141--23EV – Front cups

| | |
|--|--|
|  <p>382.0227 front cup Ø27 – grooved used with cup support arm 114.0306</p> | <p>Optional extra</p>  <p>482.0227 front cup Ø27 - grooved with material support, used with cup support arm 114.0306</p> |
| <p>Optional extra for small children's shoes</p>  <p>382.0229 front cup Ø20 - grooved used with cup support arm 114.0306</p> | <p>Optional extra for special applications</p>  <p>282.0288 front cup Ø16 - grooved used with cup support arm 114.0306</p> |
| <p>Optional extra for special applications</p>  <p>282.0289 front cup Ø16 - grooved used with cup support arm 114.0306</p> | <p>Optional extra for special applications</p>  <p>282.0291 front cup Ø16 – crossed pitch used with cup support arm 114.0306</p> |
| <p>Optional extra for California shoes</p>  <p>482.0238 front cup Ø27 - grooved used with cup support arm 114.0306</p> | <p>Optional extra for California shoes</p>  <p>382.0239 front cup Ø20 - grooved used with cup support arm 114.0306</p> |

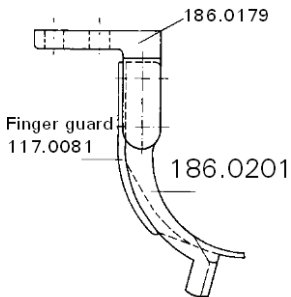
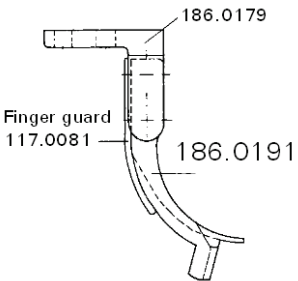
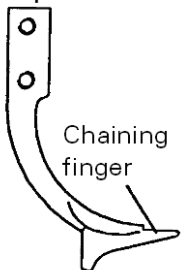
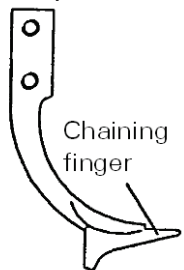
Class 141-23EV – Material guides

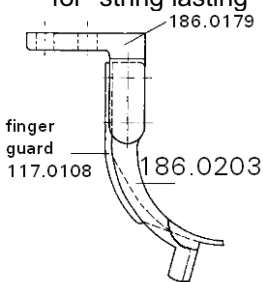
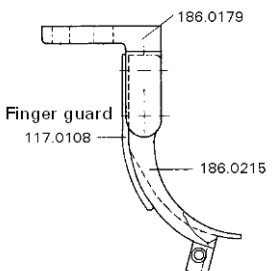
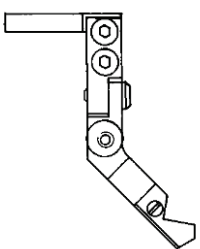
| | |
|---|--|
|  <p>186.0179 Finger guard 117.0081 186.0201</p> <p>material guide - 4.7 mm height</p> | <p>Optional extra</p>  <p>186.0179 Finger guard 117.0081 186.0191</p> <p>material guide – 3.7 mm height</p> |
| <p>Optional extra</p>  <p>Chaining finger</p> <p>186.0323 material guide – 3 mm height with chaining finger for loose seam</p> | <p>Optional extra</p>  <p>Chaining finger</p> <p>186.0324 material guide – 4.2 mm height with chaining finger for loose seam</p> |
| <p>Optional extra</p>  <p>186.0326 material guide – 3 mm height</p> | <p>Optional extra for “string lasting”</p>  <p>186.0179 finger guard 117.0108 186.0203</p> <p>material guide for strings up to Ø1.7 mm</p> |
| <p>Optional extra for “string lasting”</p>  <p>186.0179 Finger guard 117.0108 186.0215</p> <p>material guide for strings up to Ø2.5 mm</p> | <p>Optional extra for California shoes</p>  <p>386.0253 height-adjustable material guide</p> |

7 **Optional extras**

7.1 **Sewing lights**

697.0245 halogen needle light 230 V with coupler plug

The lamps are screwed to the table top and connected to control box or the main switch (Fig. 1). If the lamp is not ordered together with the machine but later, the connecting cable has to be installed according to the connecting diagram (see mechanics or sewing drive instructions).

Und wir können noch mehr für Sie tun!

Unser Lieferprogramm bietet für jede Branche und jegliche Anforderung genau die richtige Problemlösung.

And we can do a lot more for you!

Our range offers the correct problem solution for every branch and for all requirements.

■ Für die Bekleidungsindustrie:

Ein- und Zweifaden-Hochleistungs-Saummaschinen

Doppelblindstich-Saummaschinen

Zweifaden-Blindstich-Staffiermaschinen

Roll- und Flachpikiermaschinen

Pikier-Automat

und

weitere Spezial-Nähmaschinen

■ *For the clothing industry:*

Single and two thread high performance hemming machines

Bluff edge hemming machines

Two thread blind stitch felling machines

Roll and flat padding machines

Automatic lapel padding machine

and other special sewing machines

■ Für die Schuhverarbeitung:

Einfaden-Überwendlichmaschinen mit und ohne Differentialtransport

■ *For the shoe industry:*

Single-thread overseaming machines with and without differential feed

■ Für Kürschnereien und Pelzkonfektion:

Pelzschnellnäher

Pelzpikiermaschine

Futterstaffiermaschine

■ *For the fur industry:*

Rapid fur sewing machines

Fur padding machine

Lining felling machine

■ Für Heimtextilien:

Ein- und Zweifaden-Blindstichmaschinen

■ *For the home textiles industry:*

Single and two thread blind stitch machines

■ Für die Polsterverarbeitung:

Ein- und Zweifaden-Überwendlichmaschinen

Ein- und Zweifaden-Blindstichmaschinen

■ *For the upholstery industry:*

Single and two thread overseaming machines

Single and two thread blind stitch machines

■ Für die Konfektion technischer Textilien:

Ein- und Zweifaden-Überwendlichmaschinen

■ *For the processing of technical textiles:*

Single and two thread overseaming machines

Noch Fragen?

Dann rufen Sie uns an, schreiben Sie uns oder kommen Sie einfach bei uns vorbei.

Sie können jederzeit weitere Informationen über unsere Produkte anfordern oder die Strobel-Nähmaschinen in unserem Ausstellungsraum live erleben. Wir freuen uns auf Sie!

Any further questions?

Then phone, write or simply come and see us. You can have further information about our products at any time, or experience the Strobel machines live in our show room. We're looking forward to meeting you!

STROBEL

Spezialmaschinen GmbH

Postfach 1242
82168 Puchheim
Siemensstraße 3
82178 Puchheim
DEUTSCHLAND

www.strobel.biz
Telefon: +49 89 80096-0
Telefax: +49 89 80096-190